

UPCOMING PLANT
IN BAHADURGARH (HARYANA)



EXISTING PLANT
IN BAHADURGARH (HARYANA)



The Range



Company Profile

Powercam Electricals (P) Ltd. was incorporated in the year 1990 with the objective of providing quality components for Electrical Control Panels, Distribution Boards and Bus Ducts. The company is operating in Indian and International Markets and producing wide range of control panel and distribution board components like Stand Off Insulators and Busbar Supports in DMC, SMC and Polyamide, MV Insulators, Push Buttons, Pilot Lamps, Current Transformers, Potential Transformers, Panels locks, Hinges, Handles, Air Vents, Document Holders, Terminal Connectors, Brass Terminal Bars and PVC Heat Shrinkable Sleeves under the brand name of **POWERMAT**

From the time of its inception, the company has grown its designing, engineering, tooling, manufacturing and testing capabilities to become the market leaders in the field. At **POWERMAT** we are striving to understand changing customer needs and enrich the quality of their products by simply making the technology readily usable for them. We are proud to have trained professionals, who study, design, develop, enhance, customize and use of various aspects of products manufactured by us. The quality and design has always been the most emphasized area at **POWERMAT** manufacturing facilities. A free technical consultancy service is available for Short Circuit Testing for designing of Power Control Centers with **POWERMAT** products. **POWERMAT** is committed for excellence in quality and our design department provides different application data to customers for ASTA, KEMA and CPRI testing. There is an on-going philosophy of research and development in providing advance solutions to customer requirement.

POWERMAT has its own compounding of DMC and SMC materials which are UL certified under different standards. The DMC and SMC materials produced are fully compliant with European Union directive 2002/95/EC for Restriction of Use of Hazardous Substances in electrical and electronic equipments (RoHS). The moulding facilities of the company have fully automatic compression moulding machines from 20 tons to 500 tons capacity, plastic injection moulding machines up to 250 Tons and zinc die casting machines up to 300 Tons. The company has Computer Aided Designing with integrated tool room facilities for producing critical dimensions of dies and moulds. By skillful composition of high quality material and tooling technology, the economics of scale have been achieved to produce low cost components without sacrificing mechanical strength and electrical performance of products.

POWERMAT has its own testing facilities for testing of raw materials, SMC, DMC and other plastic components for physical, mechanical and electrical properties as per ASTM, IEC, JIS and UL test methods. The jigs and fixtures are designed for testing different finished components depending on their application in the final product use.

The company is always willing to accept ideas provided by its employees at all levels and its valued customers for its product use in control panels, Bus Ducts, Rising Main and Distribution Boards and translates those ideas various type of products which has resulted into one of the largest range of Busbar Supports and Stand Off Insulators.

The Future

POWERMAT aims to continue to grow exponentially through major expansion programs in the coming years by introducing a range of products for electric panel boards. The **POWERMAT** group is currently investing heavily in research and development of new components for control panels. Thus the next few years will further see a stream of new **POWERMAT** products coming into the market.

POWERMAT.....

Quality Certifications



Certificate of Registration
(Quality Management System)
KVQA CERTIFICATION SERVICES PVT. LTD.
This is to certify that the Quality Management System of
POWERCAM ELECTRICALS (P) LTD.
11, MIE, Bahadurgarh, Haryana, India.
Has been found to be of the Quality Management System Standard
ISO 9001:2015
This certificate is valid for the following product or service range
**Design & Manufacturing of Bus Bar Insulator and Supports
in DMC & SMC**

Certificate No: **KDACQ201711059**
Date Of Issue: 10, November, 2017
Valid Until: 09, November, 2020*

1st Surveillance Due On: 10/10/2018: Done On:
2nd Surveillance Due On: 10/10/2019: Done On:



Issued by 
Authorised signatory KVQA



DAC (Dubai Accreditation Centre) is a department within Dubai Municipality and is responsible for providing accreditation of conformity assessment bodies (CABs) in the fields of certification and inspection. Accreditation of DAC demonstrates the competence and independence of KVQA.
Accredited by a member of IAF's MLA for Quality Systems
To Check the Status of the Certification kindly log on to www.kvqa.in
F-300, Sector-63, Noida U.P., India. Ph-011-22711940, 22711941, email: delhi@kvqaindia.com
*Subject to successful completion of surveillance audits.





Certificate of Registration
(Environment Management System)
KVQA CERTIFICATION SERVICES PVT. LTD.
This is to certify that the Environment Management System of
POWERCAM ELECTRICALS (P) LTD.
11, MIE, Bahadurgarh, Haryana, India.
Has been found to the Environment Management System Standard
AS/NZS ISO 14001:2004/ISO 14001:2004
This certificate is valid for the following product or service range
**Design & Manufacturing of Bus Bar Insulator & Supports
in DMC & SMC.**

Certificate No: **IESC201505002**
Date Of Issue: 12, May, 2015
Valid Until: 11, May, 2018*

1st Surveillance Due On: 12/04/2016: Done On:
2nd Surveillance Due On: 12/04/2017: Done On:



Issued by 
Authorised signatory KVQA



JAS-ANZ is the government-appointed accreditation body for Australia and New Zealand responsible for providing accreditation of conformity assessment bodies (CABs) in the fields of certification and inspection. Accreditation by JAS-ANZ demonstrates the competence and independence of these CABs.
Accredited by a member of IAF's MLA for Quality Systems
To Check the Status of the Certification kindly log on to www.kvqa.in
F-300, Sector-63, Noida U.P., India. Ph-011-22711940, 22711941, email: delhi@kvqaindia.com
*Subject to successful completion of surveillance audits.



Certificate OF REGISTRATION

Powercam Electricals Private Limited

Address: F-9, Shopping Centre-I, Mansarovar Garden, New Delhi-110015
Manufacturing Site: 11, M.I.E, Bahadurgarh, Haryana 124507, India

has submitted Declaration of Conformity (Ref. No. P1230-01, Dated: 30-12-2015) according to

Council Low Voltage Directive 2006/95/EC
IEC-60947-5-1, IEC-60044-1:1996, EN:14598-3:5.

Organization has been assessed and found to be conforming with the requirements of the stated directive and standards submitted through Declaration of conformity

Hence manufacturer places the CE marking with his own responsibility as follows:



For the Products of

Current Transformers, SMC & BMC based Bus bar supports and standoff insulators, Pilot Lights, Push Button, Polyamide Based Standoff Insulators and bus bar Supports under the brand name "Powermat"

(Further description of the products / devices covered by this certificate are given in the Annexure attached)
By QSA International, UK

Certification Issue Date: 20 Feb 2016 – Certification Expiry Date: 19 Feb 2017



Quality System Assessment International Limited
27, Old Gloucester Street,
London, WC1N 3AX, ENGLAND

Certification Manager

Registration Number : QSA-1502392
Initial Certification Date: 20 Feb 2013
Re-Certification Date: 20 Feb 2016
Certification Expiry Date: 19 Feb 2019



CGA
Centre for Global Accreditation
Accreditation No. AB-148001

website: www.qsa.co.uk
e-mail: qa@international@yahoo.co.uk
Registered with Registrar of Companies for England and Wales through Registration Number 8829525
This certificate is a property of QSA International, UK. This certificate must not be altered in anyway and shall be returned upon the request by QSA International.



File No. : E249670
QMFZ2.E249670
QMFZ8.E249670
QEUY2.E314972

Control and Signalling Devices Ø22.5 - Metallic Series

POWERMAT is well known brand in the field of Bus bar Support & Insulator. Our Technical expertise has achieved various landmark in the field of Insulators & Bus Bar Supports. Now POWERMAT introduces Control & Signalling Device - Metallic Series.

Superior Design

Ø22.5 mm push button is designed and manufactured to demanding performance specification. Using state of art solid modelling techniques and finite element analysis, every component built into our series is optimised for durability and performance.

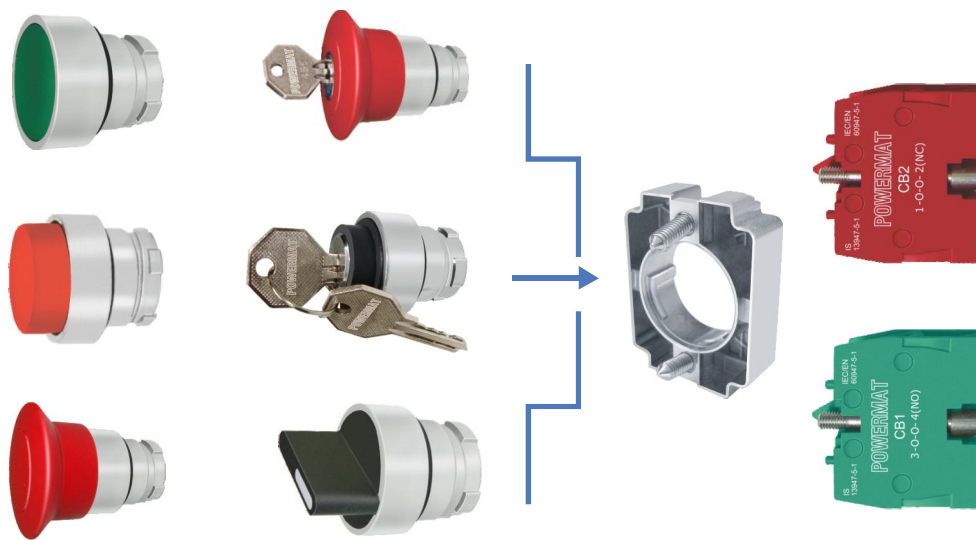

Ease in Assembly

POWERMAT provides Multiple Range of Normal & Selector Actuator with almost common & easy assembly option without much trouble & Hardware, hence to reduce the inventory time, labour & save the money.

Durable Materials

Control & signalling devices are made up of industrial grade thermoplastic for superior Electrical and Chemical Resistance. Highly precise dies are used to mould the component to keep in mind to comply with all national & international standards.

Modular Flexibility & Sealing

Aesthetically good design & Nitrile Rubber seals are used to prevent the entrance of dust, dirt & moisture into the panel body. All norms of Degree of Protections are as per IEC 60529.

Contact Blocks - Normally Open (NO) & Normally Closed (NC)

Description

Contact element are double break & have self wiping contacts. The elements are interchangeable and can be staked without additional hardware.

Moving Contacts - Phosphor Bronze Tin Plated for better conductivity

Fixed Contacts - Electrical Grade Copper Tin Plated.

Contact Point - Bimetal (Copper & Silver) 0.26 mm Silver layer



CB1 (NO)



CB2 (NC)

Conformity & Standard Operational Conditions

Standard Conformity	CSA - C22.2 No. 14-95 , IEC-60947-5-1
Degree of Protection (Actuator)	IP 65 as per IEC 60529
Ambient	minus 25°C to 70°C
Operating Position	All Position

Electricals and Mechanical Characteristics Environment

Rated Insulation Voltage	500 V
Rated Thermal Current	10 Amp.
Contact	Self Wiping, Slow Break NO or NC
Make and break capacity	AC 15 : 415 V AC , 4 A
as per IEC 60947-5-1	DC 13: 110 V DC , 0,5 A
Terminal Capacity	Min 1 x 0.5 mm ² , max. 2 x 1.5 mm ² or 1 x 2.5 mm ²
Terminal Marking	1-2 for NC , 3-4 for NO
Short Circuit Protection	10 A cartridge fuse HRC type, rated for resistive loading
Mechanical Life	Over 1 million operations

Electric Rating	AC 15	V	24	120	230
		A	4	3	2
operation at 3600 cycles per hours, load factor 0.5)	DC 13	V	24	110	
		A	0.5	0.2	

Non Illuminated Actuators

Flush Type



Product Description	Element	Switch Action	Color	Contact Element Code	Code
Ø22 mm Compact Push Button, Metallic Series, Chrome Plated Outer & Inner Body, Without Marking	1 NO + 1 NC 1 NO + 1 NO 1 NC + 1 NC 1 NC + 1 NO	Momentary Type	RED	CB1 for NO	PFT01R
			BLUE		PFT01B
			GREEN		PFT01G
			YELLOW	CB2 for NC	PFT01Y
			BLACK		PFT01K
			WHITE		PFT01W

Projecting Type



Ø22 mm Compact Push Button, Metallic Series, Chrome Plated Outer & Inner Body, Without Marking	1 NO + 1 NC 1 NO + 1 NO 1 NC + 1 NC 1 NC + 1 NO	Momentary Type	RED	CB1 for NO	PPT01R
			BLUE		PPT01B
			GREEN		PPT01G
			YELLOW	CB2 for NC	PPT01Y
			BLACK		PPT01K
			WHITE		PPT01W

Mushroom Ø40 mm (Momentary Type)



Ø40 mm Mushroom Type, Metallic Series, Chrome Plated Outer & Inner Body, Without Marking	1 NO + 1 NC 1 NO + 1 NO 1 NC + 1 NC 1 NC + 1 NO	Momentary Type	RED	CB1 for NO	PMT01R
				CB2 for NC	

Mushroom Ø40 mm (Latching Type)



Ø40 mm Mushroom Type, Metallic Series, Chrome Plated, Press to Lock and Turn to Reset	1 NO + 1 NC 1 NO + 1 NO 1 NC + 1 NC 1 NC + 1 NO	Maintained Type	RED	CB1 for NO	PML01R
				CB2 for NC	

Mushroom Ø40 mm (Latching with Key Type)



Ø40 mm Mushroom Type, Metallic Series, Chrome Plated Outer & Inner Body, Without Marking	1 NO + 1 NC 1 NO + 1 NO 1 NC + 1 NC 1 NC + 1 NO	Maintained Type	RED	CB1 for NO	PMK01R
				CB2 for NC	

Selector Actuator (Key Selector)



Ø22 mm Selector Actuator (Key Selector), Metallic Series, Chrome Plated Outer & Inner Body	1 NO + 1 NC 1 NO + 1 NO 1 NC + 1 NC 1 NC + 1 NO	Maintained Type	BLACK	CB1 for NO	PSK01K
				CB2 for NC	

Selector Actuator (Two Position, Three Position & Spring Return)



Ø22 mm Selector Actuator (Two Position & Three Position), Metallic Series, Chrome Plated Outer & Inner Body	1 NO + 1 NC 1 NO + 1 NO 1 NC + 1 NC 1 NC + 1 NO	Maintained Type	BLACK	CB1 for NO	PST01K
		L R			
		L C R			
		Momentary Type			
				CB2 for NC	PSR01K
		L R			

Pilot Lights (Super Bright LED Light)



Description

Pilot Lights has a variant from 12 V AC/DC to 240 V AC & 220 V DC. Three Super Bright LED which collectively give Lux from 450 to 2000. The design of Lense & Reflector is done in such a way that the emitting light will have a wider visibility. All component in Pilot Lights are PCB Mounted & tight fit in terminals made up of Phosphor Bronze whose spring action provide a strong & tougher grip to PCB. Back cover is provided in the same color of the pilot light. This will ease the task of a person while fixing wire at the backside of Panel.

Technical Specification

Current Consumption (Applicable to all colours)

12 VAC/DC , 110 VAC & 240 VAC

Max. 20 mA

110 VDC

Max. 15 mA

220 VDC

Max. 10 mA

Service Life (at nominal voltage & at ambient temp of 25 deg. C)

100,000 hours

Voltage limits (nominal voltage)

< 20% of rated Volt. >

Terminal Capacity

min. 1 x 0.5 mm² ,max. 2 x 1.5 mm² or 1 x 2.5 mm²

Maximum Lumen @ lense of Pilot Lamp

DESCRIPTION	INTENSITY IN LUX * (Depending on Voltage)
Super Bright Red Color	700 - 1000
Super Bright Blue Color	450 - 700
Super Bright Yellow Color	750 - 925
Super Bright Green Color	1500 - 1900
Super Bright White Color	2000 - 2500
Super Bright Amber Color	500 - 700

Pilot Lights (12 V AC/DC to 240 V AC/DC)



DESCRIPTION	CAT. NO.
POWER LED Indicator Red 12V AC/DC	PLR012AD
POWER LED Indicator Red 24V AC/DC	PLR024AD
POWER LED Indicator Red 30V AC/DC	PLR030AD
POWER LED Indicator Red 48V AC/DC	PLR048AD
POWER LED Indicator Red 110V AC	PLR110A
POWER LED Indicator Red 110V DC	PLR110D
POWER LED Indicator Red 240V AC	PLR240A
POWER LED Indicator Red 220V DC	PLR220D



DESCRIPTION	CAT. NO.
POWER LED Indicator Blue 12V AC/DC	PLB012AD
POWER LED Indicator Blue 24V AC/DC	PLB024AD
POWER LED Indicator Blue 30V AC/DC	PLB030AD
POWER LED Indicator Blue 48V AC/DC	PLB048AD
POWER LED Indicator Blue 110V AC	PLB110A
POWER LED Indicator Blue 110V DC	PLB110D
POWER LED Indicator Blue 240V AC	PLB240A
POWER LED Indicator Blue 220V DC	PLB220D



DESCRIPTION	CAT. NO.
POWER LED Indicator Green 12V AC/DC	PLG012AD
POWER LED Indicator Green 24V AC/DC	PLG024AD
POWER LED Indicator Green 30V AC/DC	PLG030AD
POWER LED Indicator Green 48V AC/DC	PLG048AD
POWER LED Indicator Green 110V AC	PLG110A
POWER LED Indicator Green 110V DC	PLG110D
POWER LED Indicator Green 240V AC	PLG240A
POWER LED Indicator Green 220V DC	PLG220D



DESCRIPTION	CAT. NO.
POWER LED Indicator Yellow 12V AC/DC	PLY012AD
POWER LED Indicator Yellow 24V AC/DC	PLY024AD
POWER LED Indicator Yellow 30V AC/DC	PLY030AD
POWER LED Indicator Yellow 48V AC/DC	PLY048AD
POWER LED Indicator Yellow 110V AC	PLY110A
POWER LED Indicator Yellow 110V DC	PLY110D
POWER LED Indicator Yellow 240V AC	PLY240A
POWER LED Indicator Yellow 220V DC	PLY220D



DESCRIPTION	CAT. NO.
POWER LED Indicator White 12V AC/DC	PLW012AD
POWER LED Indicator White 24V AC/DC	PLW024AD
POWER LED Indicator White 30V AC/DC	PLW030AD
POWER LED Indicator White 48V AC/DC	PLW048AD
POWER LED Indicator White 110V AC	PLW110A
POWER LED Indicator White 110V DC	PLW110D
POWER LED Indicator White 240V AC	PLW240A
POWER LED Indicator White 220V DC	PLW220D



DESCRIPTION	CAT. NO.
POWER LED Indicator Amber 12V AC/DC	PLA012AD
POWER LED Indicator Amber 24V AC/DC	PLA024AD
POWER LED Indicator Amber 30V AC/DC	PLA030AD
POWER LED Indicator Amber 48V AC/DC	PLA048AD
POWER LED Indicator Amber 110V AC	PLA110A
POWER LED Indicator Amber 110V DC	PLA110D
POWER LED Indicator Amber 240V AC	PLA240A
POWER LED Indicator Amber 220V DC	PLA220D

Current Transformer

In continuance with the objective of delivering Quality Components for Electric Control Panels, Distribution Boards and Bus Ducts, now We are pleased to announce our Range of **METERING, PROTECTIVE, SUMMATION, SPECIAL CLASS X & INTER-POSING CURRENT TRANSFORMERS**. We have facility to manufacture Current Transformer in Resin Cast, Tape Wound & Molded Case with different Burden (1.25VA to 30VA or as Customized by Customer), Class Ratios (0.2, 0.5, 1, 3 & 5) & Insulation Class (A, B & F)

A Current Transformer is defined as "an instrument transformer in which the secondary current is substantially proportional to the primary current (under normal conditions of operation) and differs in phase from it by an angle which is approximately zero for an appropriate direction of the connections." This highlights the accuracy requirement of the current transformer but also important is the isolating function, which means no matter what the system voltage the secondary circuit need be insulated only for a low voltage.

The Current Transformer works on the principle of variable flux. In the "ideal" Current Transformer, secondary current would be exactly equal (when multiplied by the turn's ratio) and opposite of the primary current. But, as in **The Voltage Transformer**, some of the primary current or the primary ampere-turns are utilized for magnetizing the core, thus leaving less than the actual primary ampere turns to be "transformed" into the secondary ampere-turns. This naturally introduces an error in the transformation. The error is classified into two-the current or ratio error and the phase error.

Metering CTs are designed with smaller cores and VA capacities. This causes metering CTs to saturate at lower secondary voltages saving sensitive connected metering devices from damaging large fault currents in the event of a primary electrical fault

Class X CTs are special designed current transformers & are used in mainly in the Balanced Protection System.

Summation CTs obtains the factorial sum of the currents of several lines belonging to one voltage system. The use of this Current Transformer is necessary when the ratios of the main current transformer are not equal in order to obtain a correct factorial sum, it is necessary to specify the ratio values of the individual main current transformer.

Inter-Posing CTs which are interposed between the main current transformer & the burden (VA) so that secondary current of the main Current Transformer is adjusted as required by the Burden. It is also used to correct for phase displacement for differential protection of transformers.

We have Lab Facility in House to Routine Test (Accuracy Test, Dielectric Insulation Test) of our Current Transformer as per IS 2705:1992, 3156:1992 & IEC 60044-1, 60044-2.

Current Transformers Tape Wound

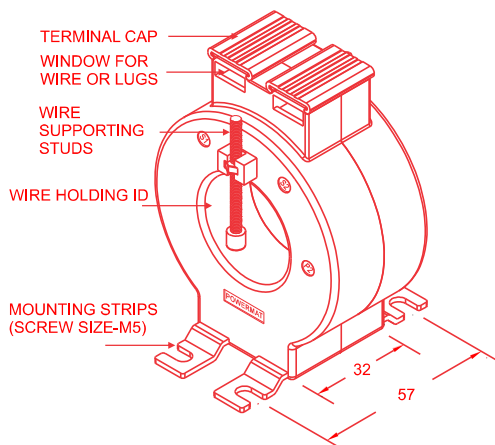
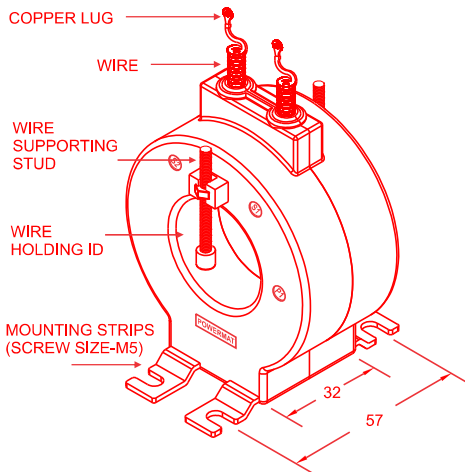
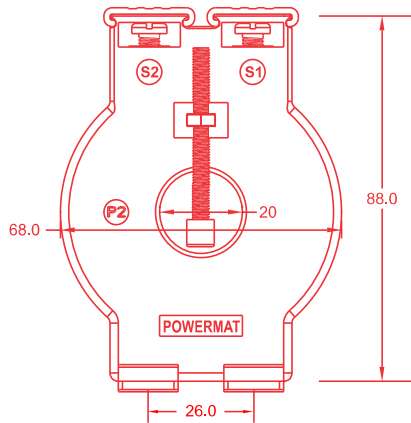

Ring Type Metering Current Transformers Tape Wound Secondary : 5A, ID : 20mm

Section : MTR 1.1

Accuracy Class : 1.0

Product Code	Ratio	Burden	Class	ID
WIRE TYPE				
MTW 30-5B-20-(4T)	25/5A	5	1.0	20
MTW 35-5B-20-(4T)	30/5A	5	1.0	20
MTW 45 -5B-20-(2T)	40/5A	5	1.0	20
MTW 55 -5B-20-(2T)	50/5A	5	1.0	20
MTW 65 -5B-20-(2T)	60/5A	5	1.0	20
MTW 85 -5B-20	80/5A	5	1.0	20
MTW 105 -5B-20	100/5A	5	1.0	20
MTW 130 -5B-20	125/5A	5	1.0	20
MTW 155 -5B-20	150/5A	5	1.0	20
TERMINAL TYPE				
MTT 30-5B-20-(4T)	25/5A	5	1.0	20
MTT 35-5B-20-(4T)	30/5A	5	1.0	20
MTT 45 -5B-20-(2T)	40/5A	5	1.0	20
MTT 55 -5B-20-(2T)	50/5A	5	1.0	20
MTT 65 -5B-20-(2T)	60/5A	5	1.0	20
MTT 85 -5B-20	80/5A	5	1.0	20
MTT 105 -5B-20	100/5A	5	1.0	20
MTT 130 -5B-20	125/5A	5	1.0	20
MTT 155 -5B-20	150/5A	5	1.0	20

Ring Type Metering Current Transformers Tape Wound Secondary : 1A, ID : 20mm

Section : MTR 1.2

Accuracy Class : 1.0

Product Code	Ratio	Burden	Class	ID
WIRE TYPE				
MTW 26-5B-20-(4T)	25/1A	5	1.0	20
MTW 31-5B-20-(4T)	30/1A	5	1.0	20
MTW 45 -5B-20-(2T)	40/1A	5	1.0	20
MTW 51 -5B-20-(2T)	50/1A	5	1.0	20
MTW 61 -5B-20-(2T)	60/1A	5	1.0	20
MTW 81 -5B-20	80/1A	5	1.0	20
MTW 101 -5B-20	100/1A	5	1.0	20
MTW 126 -5B-20	125/1A	5	1.0	20
MTW 151 -5B-20	150/1A	5	1.0	20
TERMINAL TYPE				
MTT 26-5B-20-(4T)	25/1A	5	1.0	20
MTT 31-5B-20-(4T)	30/1A	5	1.0	20
MTT 41 -5B-20-(2T)	40/1A	5	1.0	20
MTT 51 -5B-20-(2T)	50/1A	5	1.0	20
MTT 61 -5B-20-(2T)	60/1A	5	1.0	20
MTT 81 -5B-20	80/1A	5	1.0	20
MTT 101 -5B-20	100/1A	5	1.0	20
MTT 126 -5B-20	125/1A	5	1.0	20
MTT 151 -5B-20	150/1A	5	1.0	20

All Dimensions are in MM • Above Current Transformers are **CE** certified.

All above mentioned CT are also available in Class 0.5, Class 3, Class 5.

Please contact your local POWERMAT sales representative for more information.

Ring Type Metering Current Transformers Tape Wound Secondary : 5A, ID : 30mm

Section : MTR 2.1

Accuracy Class : 1.0

Product Code	Ratio	Burden	Class	ID
WIRE TYPE				
MTW 30-5B-30-(4T)	25/5A	5	1.0	30
MTW 35-5B-30-(4T)	30/5A	5	1.0	30
MTW 45 -5B-30-(2T)	40/5A	5	1.0	30
MTW 55 -5B-30-(2T)	50/5A	5	1.0	30
MTW 65 -5B-30-(2T)	60/5A	5	1.0	30
MTW 85 -5B-30	80/5A	5	1.0	30
MTW 105 -5B-30	100/5A	5	1.0	30
MTW 130 -5B-30	125/5A	5	1.0	30
MTW 155 -5B-30	150/5A	5	1.0	30
MTW 205 -5B-30	200/5A	5	1.0	30
MTW 255 -5B-30	250/5A	5	1.0	30
TERMINAL TYPE				
MTT 30-5B-30-(4T)	25/5A	5	1.0	30
MTT 35-5B-30-(4T)	30/5A	5	1.0	30
MTT 45 -5B-30-(2T)	40/5A	5	1.0	30
MTT 55 -5B-30-(2T)	50/5A	5	1.0	30
MTT 65 -5B-30-(2T)	60/5A	5	1.0	30
MTT 85 -5B-30	80/5A	5	1.0	30
MTT 105 -5B-30	100/5A	5	1.0	30
MTT 130 -5B-30	125/5A	5	1.0	30
MTT 155 -5B-30	150/5A	5	1.0	30
MTT 205 -5B-30	200/5A	5	1.0	30
MTT 255 -5B-30	250/5A	5	1.0	30

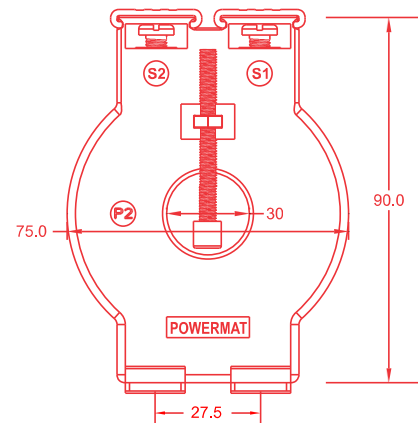

Ring Type Metering Current Transformers Tape Wound Secondary : 1A, ID : 30mm

Section : MTR 2.2

Accuracy Class : 1.0

Product Code	Ratio	Burden	Class	ID
WIRE TYPE				
MTW 26-5B-30-(4T)	25/1A	5	1.0	30
MTW 31-5B-30-(4T)	30/1A	5	1.0	30
MTW 41 -5B-30-(2T)	40/1A	5	1.0	30
MTW 51 -5B-30-(2T)	50/1A	5	1.0	30
MTW 61 -5B-30-(2T)	60/1A	5	1.0	30
MTW 81 -5B-30	80/1A	5	1.0	30
MTW 101 -5B-30	100/1A	5	1.0	30
MTW 126 -5B-30	125/1A	5	1.0	30
MTW 151 -5B-30	150/1A	5	1.0	30
MTW 201 -5B-30	200/1A	5	1.0	30
MTW 251 -5B-30	250/1A	5	1.0	30
TERMINAL TYPE				
MTT 26-5B-30-(4T)	25/1A	5	1.0	30
MTT 31-5B-30-(4T)	30/1A	5	1.0	30
MTT 41 -5B-30-(2T)	40/1A	5	1.0	30
MTT 51 -5B-30-(2T)	50/1A	5	1.0	30
MTT 61 -5B-30-(2T)	60/1A	5	1.0	30
MTT 81 -5B-30	80/1A	5	1.0	30
MTT 101 -5B-30	100/1A	5	1.0	30
MTT 126 -5B-30	125/1A	5	1.0	30
MTT 151 -5B-30	150/1A	5	1.0	30
MTT 201 -5B-30	200/1A	5	1.0	30
MTT 251 -5B-30	250/1A	5	1.0	30

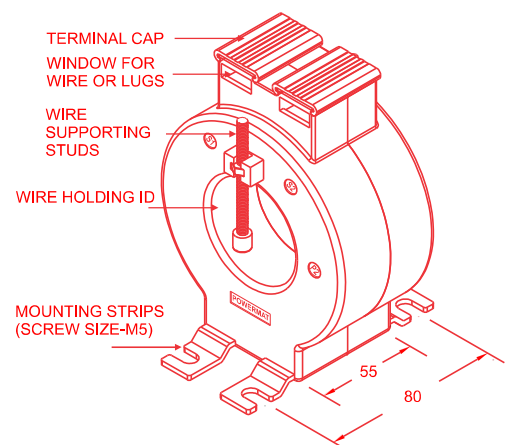
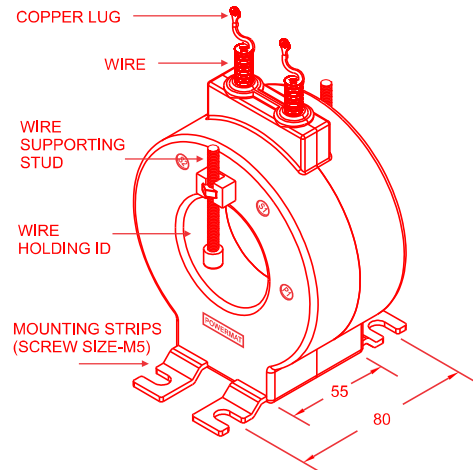

All Dimensions are in MM • Above Current Transformers are **CE** certified.

All above mentioned CT are also available in Class 0.5, Class 3, Class 5.
Please contact your local POWERMAT sales representative for more information.

Current Transformers Tape Wound

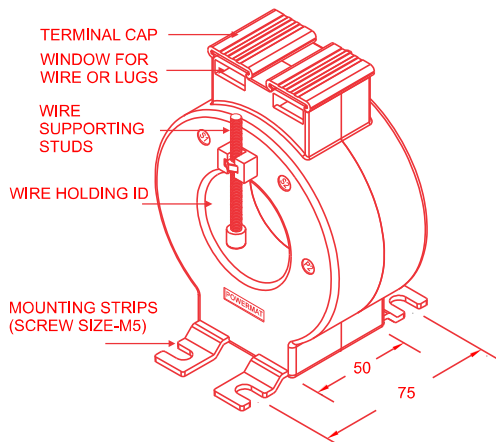
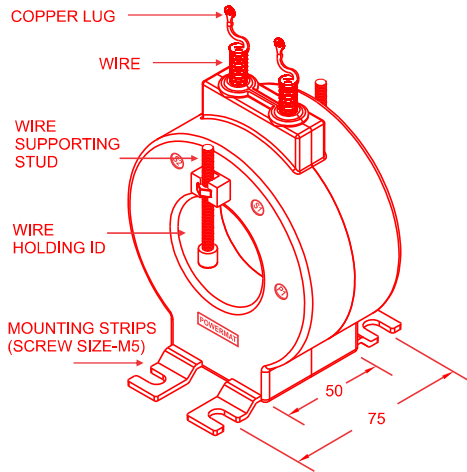
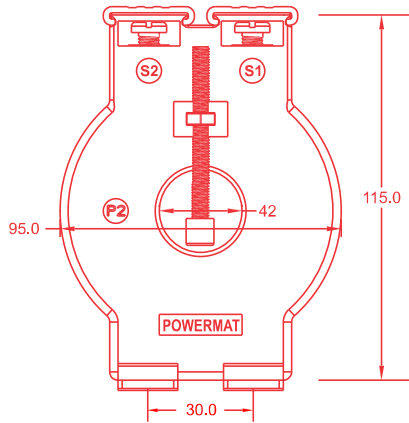

Ring Type Metering Current Transformers Tape Wound Secondary : 5A, ID : 42mm

Section : MTR 3.1

Accuracy Class : 1.0

Product Code	Ratio	Burden	Class	ID
WIRE TYPE				
MTW 205 -5B-42	200/5A	5	1.0	42
MTW 205 -10B-42	200/5A	10	1.0	42
MTW 255 -5B-42	250/5A	5	1.0	42
MTW 255 -10B-42	250/5A	10	1.0	42
MTW 305 -5B-42	300/5A	5	1.0	42
MTW 305 -10B-42	300/5A	10	1.0	42
MTW 405 -5B-42	400/5A	5	1.0	42
MTW 405 -10B-42	400/5A	10	1.0	42
TERMINAL TYPE				
MTT 205 -5B-42	200/5A	5	1.0	42
MTT 205 -10B-42	200/5A	10	1.0	42
MTT 255 -5B-42	250/5A	5	1.0	42
MTT 255 -10B-42	250/5A	10	1.0	42
MTT 305 -5B-42	300/5A	5	1.0	42
MTT 305 -10B-42	300/5A	10	1.0	42
MTT 405 -5B-42	400/5A	5	1.0	42
MTT 405 -10B-42	400/5A	10	1.0	42

Ring Type Metering Current Transformers Tape Wound Secondary : 1A, ID : 42mm

Section : MTR 3.2

Accuracy Class : 1.0

Product Code	Ratio	Burden	Class	ID
WIRE TYPE				
MTW 201 -5B-42	200/1A	5	1.0	42
MTW 201 -10B-42	200/1A	10	1.0	42
MTW 251 -5B-42	250/1A	5	1.0	42
MTW 251 -10B-42	250/1A	10	1.0	42
MTW 301 -5B-42	300/1A	5	1.0	42
MTW 301 -10B-42	300/1A	10	1.0	42
MTW 401 -5B-42	400/1A	5	1.0	42
MTW 401 -10B-42	400/1A	10	1.0	42
TERMINAL TYPE				
MTT 201 -5B-42	200/1A	5	1.0	42
MTT 201 -10B-42	200/1A	10	1.0	42
MTT 251 -5B-42	250/1A	5	1.0	42
MTT 251 -10B-42	250/1A	10	1.0	42
MTT 301 -5B-42	300/1A	5	1.0	42
MTT 301 -10B-42	300/1A	10	1.0	42
MTT 401 -5B-42	400/1A	5	1.0	42
MTT 401 -10B-42	400/1A	10	1.0	42

All Dimensions are in MM • Above Current Transformers are CE certified.
All above mentioned CT are also available in Class 0.5, Class 3, Class 5.
Please contact your local POWERMAT sales representative for more information.

POWERMAT.....

Current Transformers Tape Wound

Ring Type Metering Current Transformers Tape Wound Secondary : 5A, ID : 57mm

Section : MTR 4.1

Accuracy Class : 1.0

Product Code	Ratio	Burden	Class	ID
WIRE TYPE				
MTW 305 -5B-57	300/5A	5	1.0	57
MTW 305 -10B-57	300/5A	10	1.0	57
MTW 405 -5B-57	400/5A	5	1.0	57
MTW 405 -10B-57	400/5A	10	1.0	57
MTW 505 -5B-57	500/5A	10	1.0	57
MTW 505 -10B-57	500/5A	15	1.0	57
MTW 605 -10B-57	600/5A	10	1.0	57
MTW 605 -15B-57	600/5A	15	1.0	57

TERMINAL TYPE

MTT 305 -5B-57	300/5A	5	1.0	57
MTT 305 -10B-57	300/5A	10	1.0	57
MTT 405 -5B-57	400/5A	5	1.0	57
MTT 405 -10B-57	400/5A	10	1.0	57
MTT 505 -5B-57	500/5A	10	1.0	57
MTT 505 -10B-57	500/5A	15	1.0	57
MTT 605 -10B-57	600/5A	10	1.0	57
MTT 605 -15B-57	600/5A	15	1.0	57

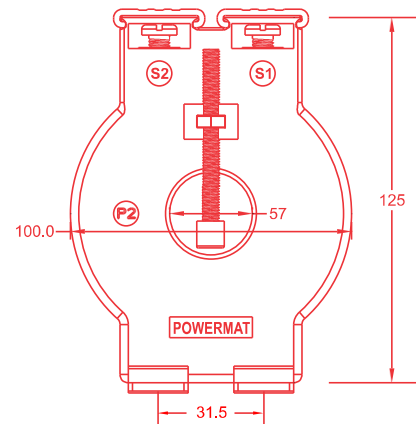

Ring Type Metering Current Transformers Tape Wound Secondary : 1A, ID : 57mm

Section : MTR 4.2

Accuracy Class : 1.0

Product Code	Ratio	Burden	Class	ID
WIRE TYPE				
MTW 301 -5B-57	300/1A	5	1.0	57
MTW 301 -10B-57	300/1A	10	1.0	57
MTW 401 -5B-57	400/1A	5	1.0	57
MTW 401 -10B-57	400/1A	10	1.0	57
MTW 501 -5B-57	500/1A	10	1.0	57
MTW 501 -10B-57	500/1A	15	1.0	57
MTW 601 -10B-57	600/1A	10	1.0	57
MTW 601 -15B-57	600/1A	15	1.0	57

TERMINAL TYPE

MTT 301 -5B-57	300/1A	5	1.0	57
MTT 301 -10B-57	300/1A	10	1.0	57
MTT 401 -5B-57	400/1A	5	1.0	57
MTT 401 -10B-57	400/1A	10	1.0	57
MTT 501 -5B-57	500/1A	10	1.0	57
MTT 501 -10B-57	500/1A	15	1.0	57
MTT 601 -10B-57	600/1A	10	1.0	57
MTT 601 -15B-57	600/1A	15	1.0	57

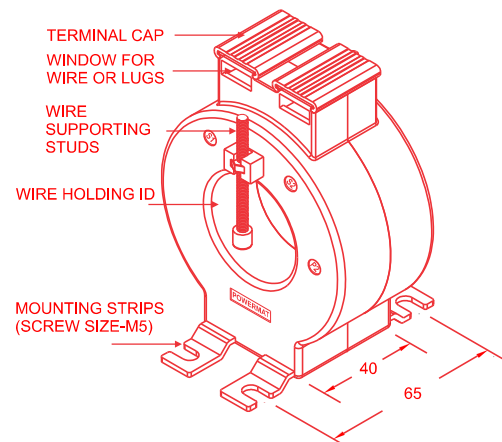
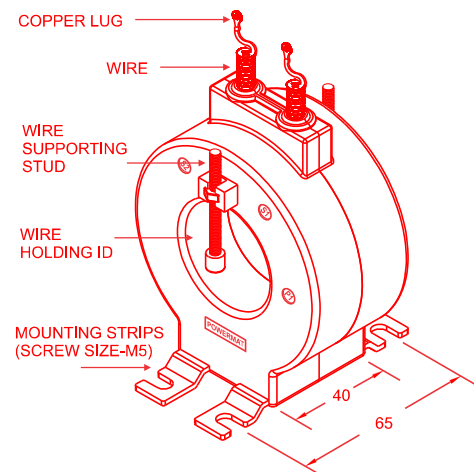

All Dimensions are in MM • Above Current Transformers are **CE** certified.
All above mentioned CT are also available in Class 0.5, Class 3, Class 5.
Please contact your local POWERMAT sales representative for more information.

Current Transformers Tape Wound

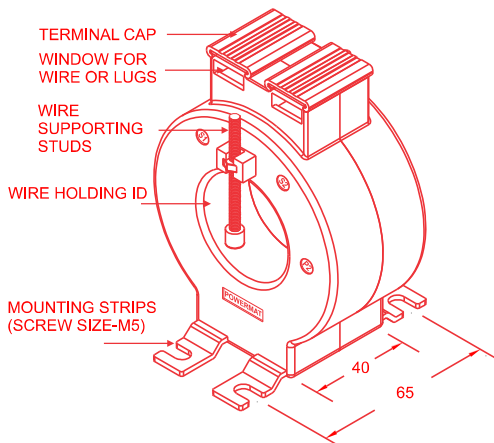
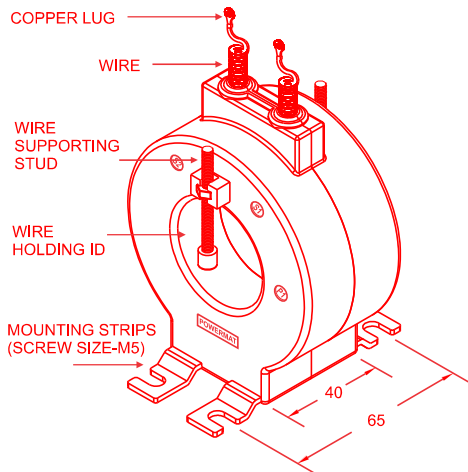
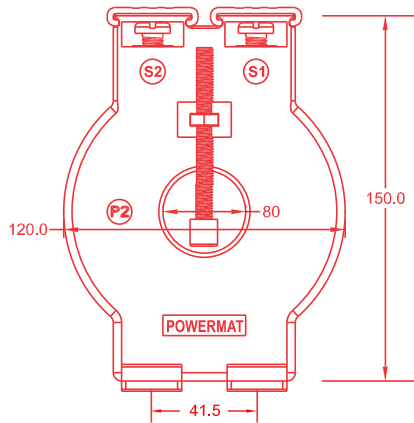

Ring Type Metering Current Transformers Tape Wound Secondary : 5A, ID : 80mm

Section : MTR 5.1

Accuracy Class : 1.0

Product Code	Ratio	Burden	Class	ID
WIRE TYPE				
MTW 505 -5B-80	500/5A	5	1.0	80
MTW 505 -10B-80	500/5A	10	1.0	80
MTW 605 -5B-80	600/5A	5	1.0	80
MTW 605 -10B-80	600/5A	10	1.0	80
MTW 805 -10B-80	800/5A	10	1.0	80
MTW 805 -15B-80	800/5A	15	1.0	80
MTW 1005 -10B-80	1000/5A	10	1.0	80
MTW 1005 -15B-80	1000/5A	15	1.0	80
TERMINAL TYPE				
MTT 505 -5B-80	500/5A	5	1.0	80
MTT 505 -10B-80	500/5A	10	1.0	80
MTT 605 -5B-80	600/5A	5	1.0	80
MTT 605 -10B-80	600/5A	10	1.0	80
MTT 805 -10B-80	800/5A	10	1.0	80
MTT 805 -15B-80	800/5A	15	1.0	80
MTT 1005 -10B-80	1000/5A	10	1.0	80
MTT 1005 -15B-80	1000/5A	15	1.0	80

Ring Type Metering Current Transformers Tape Wound Secondary : 1A, ID : 80mm

Section : MTR 5.2

Accuracy Class : 1.0

Product Code	Ratio	Burden	Class	ID
WIRE TYPE				
MTW 501 -5B-80	500/1A	5	1.0	80
MTW 501 -10B-80	500/1A	10	1.0	80
MTW 601 -5B-80	600/1A	5	1.0	80
MTW 601 -10B-80	600/1A	10	1.0	80
MTW 801 -10B-80	800/1A	10	1.0	80
MTW 801 -15B-80	800/1A	15	1.0	80
MTW 1001 -10B-80	1000/1A	10	1.0	80
MTW 1001 -15B-80	1000/1A	15	1.0	80
TERMINAL TYPE				
MTT 501 -5B-80	500/1A	5	1.0	80
MTT 501 -10B-80	500/1A	10	1.0	80
MTT 601 -5B-80	600/1A	5	1.0	80
MTT 601 -10B-80	600/1A	10	1.0	80
MTT 801 -10B-80	800/1A	10	1.0	80
MTT 801 -15B-80	800/1A	15	1.0	80
MTT 1001 -10B-80	1000/1A	10	1.0	80
MTT 1001 -15B-80	1000/1A	15	1.0	80

All Dimensions are in MM • Above Current Transformers are CE certified.

All above mentioned CT are also available in Class 0.5, Class 3, Class 5.

Please contact your local POWERMAT sales representative for more information.

POWERMAT

Current Transformers Tape Wound

Ring Type Metering Current Transformers Tape Wound Secondary : 5A, ID : 110mm

Section : MTR 6.1

Accuracy Class : 1.0

Product Code	Ratio	Burden	Class	ID
WIRE TYPE				
MTW 1205 -10B-110	1200/5A	10	1.0	110
MTW 1205 -15B-110	1200/5A	15	1.0	110
MTW 1605 -10B-110	1600/5A	10	1.0	110
MTW 1605 -15B-110	1600/5A	15	1.0	110
MTW 2005 -10B-110	2000/5A	10	1.0	110
MTW 2005 -15B-110	2000/5A	15	1.0	110
MTW 2505 -10B-110	2500/5A	10	1.0	110
MTW 2505 -15B-110	2500/5A	15	1.0	110

Product Code	Ratio	Burden	Class	ID
TERMINAL TYPE				
MTT 1205 -10B-110	1200/5A	10	1.0	110
MTT 1205 -15B-110	1200/5A	15	1.0	110
MTT 1605 -10B-110	1600/5A	10	1.0	110
MTT 1605 -15B-110	1600/5A	15	1.0	110
MTT 2005 -10B-110	2000/5A	10	1.0	110
MTT 2005 -15B-110	2000/5A	15	1.0	110
MTT 2505 -10B-110	2500/5A	10	1.0	110
MTT 2505 -15B-110	2500/5A	15	1.0	110

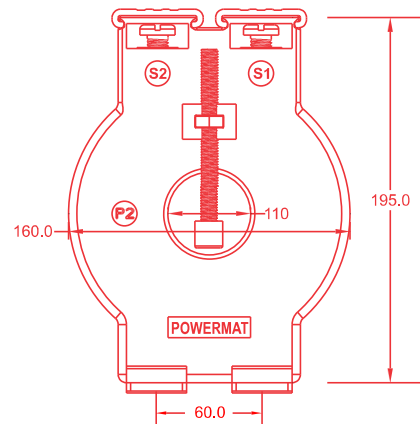

Ring Type Metering Current Transformers Tape Wound Secondary : 1A, ID : 110mm

Section : MTR 6.2

Accuracy Class : 1.0

Product Code	Ratio	Burden	Class	ID
WIRE TYPE				
MTW 1201 -10B-110	1200/1A	10	1.0	110
MTW 1201 -15B-110	1200/1A	15	1.0	110
MTW 1601 -10B-110	1600/1A	10	1.0	110
MTW 1601 -15B-110	1600/1A	15	1.0	110
MTW 2001 -10B-110	2000/1A	10	1.0	110
MTW 2001 -15B-110	2000/1A	15	1.0	110
MTW 2501 -10B-110	2500/1A	10	1.0	110
MTW 2501 -15B-110	2500/1A	15	1.0	110

Product Code	Ratio	Burden	Class	ID
TERMINAL TYPE				
MTT 1201 -10B-110	1200/1A	10	1.0	110
MTT 1201 -15B-110	1200/1A	15	1.0	110
MTT 1601 -10B-110	1600/1A	10	1.0	110
MTT 1601 -15B-110	1600/1A	15	1.0	110
MTT 2001 -10B-110	2000/1A	10	1.0	110
MTT 2001 -15B-110	2000/1A	15	1.0	110
MTT 2501 -10B-110	2500/1A	10	1.0	110
MTT 2501 -15B-110	2500/1A	15	1.0	110

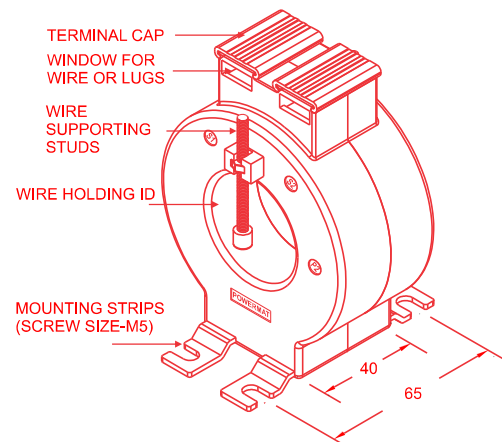
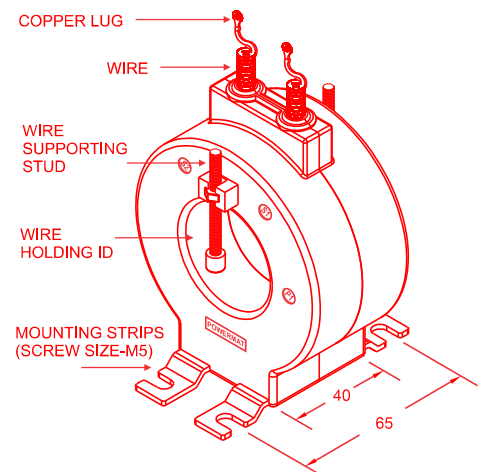

All Dimensions are in MM • Above Current Transformers are **CE** certified.
All above mentioned CT are also available in Class 0.5, Class 3, Class 5.
Please contact your local POWERMAT sales representative for more information.

Current Transformers Resin Cast

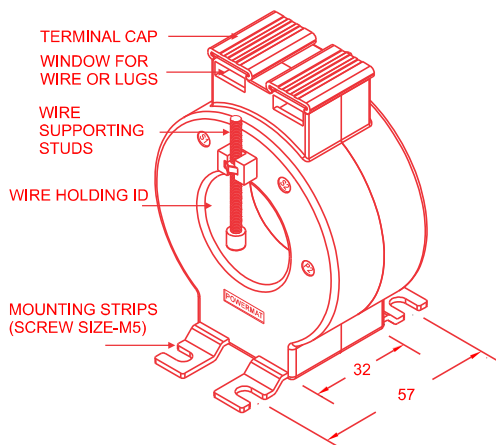
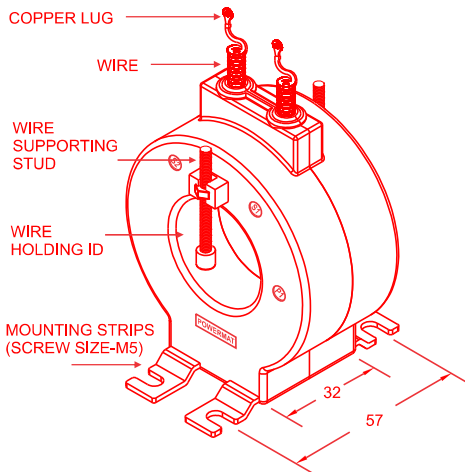
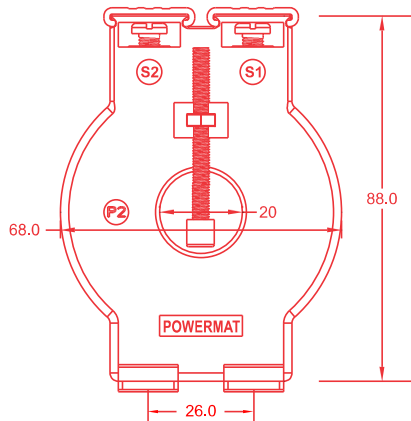

Ring Type Metering Current Transformers Resin Cast Secondary : 5A, ID : 20mm

Section : MTR 1.1

Accuracy Class : 1.0

Product Code	Ratio	Burden	Class	ID
RESIN CAST WIRE				
MRW 30-5B-20-(4T)	25/5A	5	1.0	20
MRW 35-5B-20-(4T)	30/5A	5	1.0	20
MRW 45 -5B-20-2T	40/5A	5	1.0	20
MRW 55 -5B-20-2T	50/5A	5	1.0	20
MRW 65 -5B-20-2T	60/5A	5	1.0	20
MRW 85 -5B-20	80/5A	5	1.0	20
MRW 105 -5B-20	100/5A	5	1.0	20
MRW 130 -5B-20	125/5A	5	1.0	20
MRW 155 -5B-20	150/5A	5	1.0	20
RESIN CAST TERMINAL				
MRT 30-5B-20-(4T)	25/5A	5	1.0	20
MRT 35-5B-20-(4T)	30/5A	5	1.0	20
MRT 45 -5B-20-2T	40/5A	5	1.0	20
MRT 55 -5B-20-2T	50/5A	5	1.0	20
MRT 65 -5B-20-2T	60/5A	5	1.0	20
MRT 85 -5B-20	80/5A	5	1.0	20
MRT 105 -5B-20	100/5A	5	1.0	20
MRT 130 -5B-20	125/5A	5	1.0	20
MRT 155 -5B-20	150/5A	5	1.0	20

Ring Type Metering Current Transformers Resin Cast Secondary : 1A, ID : 20mm

Section : MTR 1.2

Accuracy Class : 1.0

Product Code	Ratio	Burden	Class	ID
RESIN CAST WIRE				
MRW 26-5B-20-(4T)	25/1A	5	1.0	20
MRW 31-5B-20-(4T)	30/1A	5	1.0	20
MRW 41 -5B-20-2T	40/1A	5	1.0	20
MRW 51 -5B-20-2T	50/1A	5	1.0	20
MRW 61 -5B-20-2T	60/1A	5	1.0	20
MRW 81 -5B-20	80/1A	5	1.0	20
MRW 101 -5B-20	100/1A	5	1.0	20
MRW 126 -5B-20	125/1A	5	1.0	20
MRW 151 -5B-20	150/1A	5	1.0	20
RESIN CAST TERMINAL				
MRT 26-5B-20-(4T)	25/1A	5	1.0	20
MRT 31-5B-20-(4T)	30/1A	5	1.0	20
MRT 41 -5B-20-2T	40/1A	5	1.0	20
MRT 51 -5B-20-2T	50/1A	5	1.0	20
MRT 61 -5B-20-2T	60/1A	5	1.0	20
MRT 81 -5B-20	80/1A	5	1.0	20
MRT 101 -5B-20	100/1A	5	1.0	20
MRT 126 -5B-20	125/1A	5	1.0	20
MRT 151 -5B-20	150/1A	5	1.0	20

All Dimensions are in MM • Above Current Transformers are CE certified.

All above mentioned CT are also available in Class 0.5, Class 3, Class 5.

Please contact your local POWERMAT sales representative for more information.

POWERMAT.....

**Ring Type Metering Current Transformers Resin Cast
Secondary : 5A, ID : 30mm**

Section : MTR 2.1

Accuracy Class : 1.0

Product Code	Ratio	Burden	Class	ID
RESIN CAST WIRE				
MRW 30-5B-30-(4T)	25/5A	5	1.0	30
MRW 35-5B-30-(4T)	30/5A	5	1.0	30
MRW 45 -5B-30-(2T)	40/5A	5	1.0	30
MRW 55 -5B-30-(2T)	50/5A	5	1.0	30
MRW 65 -5B-30-(2T)	60/5A	5	1.0	30
MRW 85 -5B-30	80/5A	5	1.0	30
MRW 105 -5B-30	100/5A	5	1.0	30
MRW 130 -5B-30	125/5A	5	1.0	30
MRW 155 -5B-30	150/5A	5	1.0	30
MRW 205 -5B-30	200/5A	5	1.0	30
MRW 255 -5B-30	250/5A	5	1.0	30

Product Code	Ratio	Burden	Class	ID
RESIN CAST TERMINAL				
MRT 30-5B-30-(4T)	25/5A	5	1.0	30
MRT 35-5B-30-(4T)	30/5A	5	1.0	30
MRT 45 -5B-30-(2T)	40/5A	5	1.0	30
MRT 55 -5B-30-(2T)	50/5A	5	1.0	30
MRT 65 -5B-30-(2T)	60/5A	5	1.0	30
MRT 85 -5B-30	80/5A	5	1.0	30
MRT 105 -5B-30	100/5A	5	1.0	30
MRT 130 -5B-30	125/5A	5	1.0	30
MRT 155 -5B-30	150/5A	5	1.0	30
MRT 205 -5B-30	200/5A	5	1.0	30
MRT 255 -5B-30	250/5A	5	1.0	30

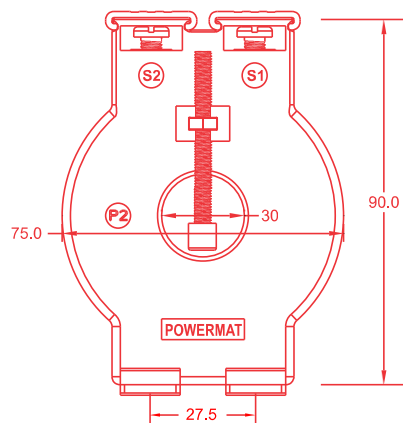

**Ring Type Metering Current Transformers Resin Cast
Secondary : 1A, ID : 30mm**

Section : MTR 2.2

Accuracy Class : 1.0

Product Code	Ratio	Burden	Class	ID
RESIN CAST WIRE				
MRW 26-5B-30-(4T)	25/1A	5	1.0	30
MRW 31-5B-30-(4T)	30/1A	5	1.0	30
MRW 41 -5B-30-(2T)	40/1A	5	1.0	30
MRW 51 -5B-30-(2T)	50/1A	5	1.0	30
MRW 61 -5B-30-(2T)	60/1A	5	1.0	30
MRW 81 -5B-30	80/1A	5	1.0	30
MRW 101 -5B-30	100/1A	5	1.0	30
MRW 126 -5B-30	125/1A	5	1.0	30
MRW 151 -5B-30	150/1A	5	1.0	30
MRW 201 -5B-30	200/1A	5	1.0	30
MRW 251 -5B-30	250/1A	5	1.0	30

Product Code	Ratio	Burden	Class	ID
RESIN CAST TERMINAL				
MRT 26-5B-30-(4T)	25/1A	5	1.0	30
MRT 31-5B-30-(4T)	30/1A	5	1.0	30
MRT 41 -5B-30-(2T)	40/1A	5	1.0	30
MRT 51 -5B-30-(2T)	50/1A	5	1.0	30
MRT 61 -5B-30-(2T)	60/1A	5	1.0	30
MRT 81 -5B-30	80/1A	5	1.0	30
MRT 101 -5B-30	100/1A	5	1.0	30
MRT 126 -5B-30	125/1A	5	1.0	30
MRT 151 -5B-30	150/1A	5	1.0	30
MRT 201 -5B-30	200/1A	5	1.0	30
MRT 251 -5B-30	250/1A	5	1.0	30

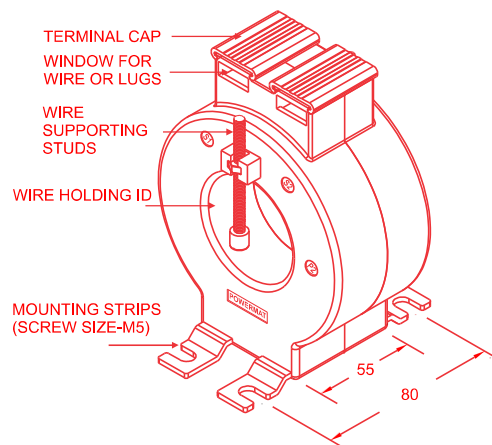
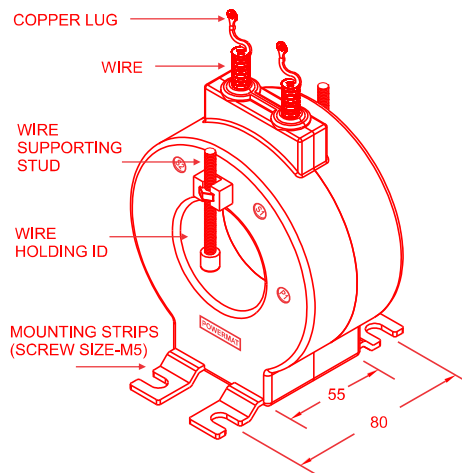

All Dimensions are in MM • Above Current Transformers are **CE** certified.
All above mentioned CT are also available in Class 0.5, Class 3, Class 5.
Please contact your local POWERMAT sales representative for more information.

Current Transformers Resin Cast

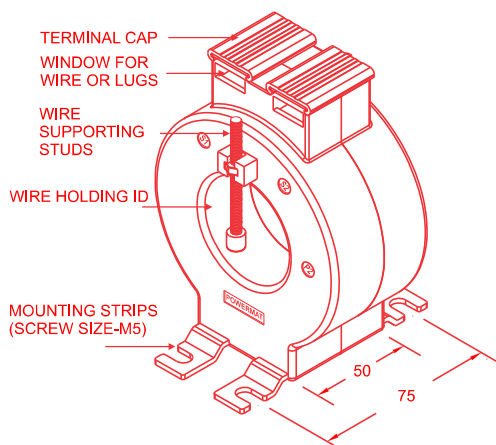
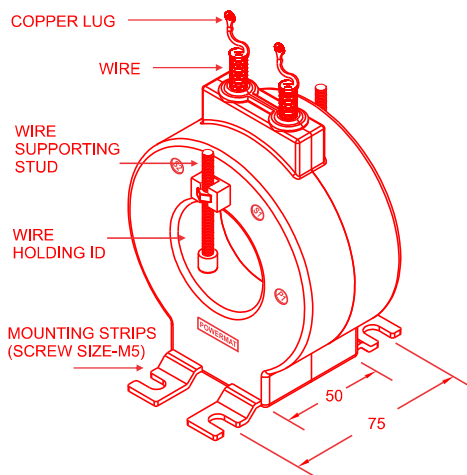
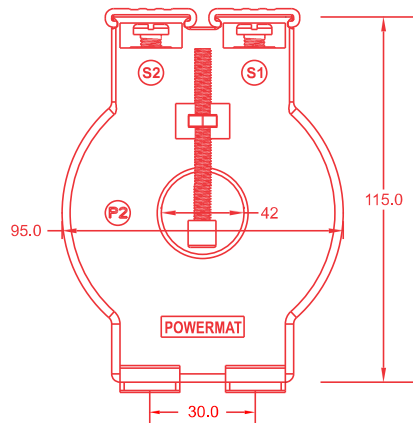

Ring Type Metering Current Transformers Resin Cast Secondary : 5A, ID : 42mm

Section : MTR 3.1

Accuracy Class : 1.0

Product Code	Ratio	Burden	Class	ID
RESIN CAST WIRE				
MRW 205 -5B-42	200/5A	5	1.0	42
MRW 205 -10B-42	200/5A	10	1.0	42
MRW 255 -5B-42	250/5A	5	1.0	42
MRW 255 -10B-42	250/5A	10	1.0	42
MRW 305 -5B-42	300/5A	5	1.0	42
MRW 305 -10B-42	300/5A	10	1.0	42
MTR 405 -5B-42	400/5A	5	1.0	42
MRW 405 -10B-42	400/5A	10	1.0	42

Product Code	Ratio	Burden	Class	ID
RESIN CAST TERMINAL				
MRT 205 -5B-42	200/5A	5	1.0	42
MRT 205 -10B-42	200/5A	10	1.0	42
MRT 255 -5B-42	250/5A	5	1.0	42
MRT 255 -10B-42	250/5A	10	1.0	42
MRT 305 -5B-42	300/5A	5	1.0	42
MRT 305 -10B-42	300/5A	10	1.0	42
MTT 405 -5B-42	400/5A	5	1.0	42
MRT 405 -10B-42	400/5A	10	1.0	42

Ring Type Metering Current Transformers Resin Cast Secondary : 1A, ID : 42mm

Section : MTR 3.2

Accuracy Class : 1.0

Product Code	Ratio	Burden	Class	ID
RESIN CAST WIRE				
MRW 201 -5B-42	200/1A	5	1.0	42
MRW 201 -10B-42	200/1A	10	1.0	42
MRW 251 -5B-42	250/1A	5	1.0	42
MRW 251 -10B-42	250/1A	10	1.0	42
MRW 301 -5B-42	300/1A	5	1.0	42
MRW 301 -10B-42	300/1A	10	1.0	42
MRW 401 -5B-42	400/1A	5	1.0	42
MRW 401 -10B-42	400/1A	10	1.0	42

Product Code	Ratio	Burden	Class	ID
RESIN CAST TERMINAL				
MRT 201 -5B-42	200/1A	5	1.0	42
MRT 201 -10B-42	200/1A	10	1.0	42
MRT 251 -5B-42	250/1A	5	1.0	42
MRT 251 -10B-42	250/1A	10	1.0	42
MRT 301 -5B-42	300/1A	5	1.0	42
MRT 301 -10B-42	300/1A	10	1.0	42
MRT 401 -5B-42	400/1A	5	1.0	42
MRT 401 -10B-42	400/1A	10	1.0	42

All Dimensions are in MM • Above Current Transformers are **CE** certified.
All above mentioned CT are also available in Class 0.5, Class 3, Class 5.
Please contact your local POWERMAT sales representative for more information.

POWERMAT.....

Ring Type Metering Current Transformers Resin Cast Secondary : 5A, ID : 57mm

Section : MTR 4.1

Accuracy Class : 1.0

Product Code	Ratio	Burden	Class	ID
RESIN CAST WIRE				
MRW 305 -5B-57	300/5A	5	1.0	57
MRW 305 -10B-57	300/5A	10	1.0	57
MRW 405 -5B-57	400/5A	5	1.0	57
MRW 405 -10B-57	400/5A	10	1.0	57
MRW 505 -5B-57	500/5A	5	1.0	57
MRW 505 -10B-57	500/5A	10	1.0	57
MRW 605 -10B-57	600/5A	10	1.0	57
MRW 605 -15B-57	600/5A	15	1.0	57
RESIN CAST TERMINAL				
MRT 305 -5B-57	300/5A	5	1.0	57
MRT 305 -10B-57	300/5A	10	1.0	57
MRT 405 -5B-57	400/5A	5	1.0	57
MRT 405 -10B-57	400/5A	10	1.0	57
MRT 505 -5B-57	500/5A	5	1.0	57
MRT 505 -10B-57	500/5A	10	1.0	57
MRT 605 -10B-57	600/5A	10	1.0	57
MRT 605 -15B-57	600/5A	15	1.0	57

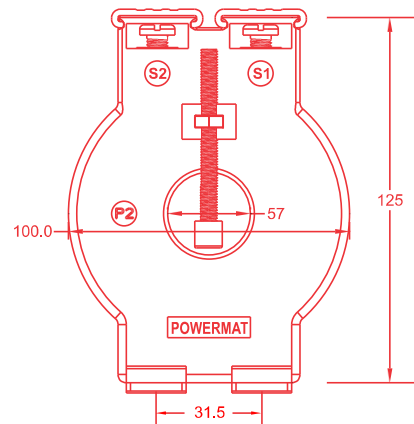

Ring Type Metering Current Transformers Resin Cast Secondary : 1A, ID : 57mm

Section : MTR 4.2

Accuracy Class : 1.0

Product Code	Ratio	Burden	Class	ID
RESIN CAST WIRE				
MRW 305 -5B-57	300/1A	5	1.0	57
MRW 305 -10B-57	300/1A	10	1.0	57
MRW 405 -5B-57	400/1A	5	1.0	57
MRW 405 -10B-57	400/1A	10	1.0	57
MRW 505 -5B-57	500/1A	5	1.0	57
MRW 505 -10B-57	500/1A	10	1.0	57
MRW 605 -10B-57	600/1A	10	1.0	57
MRW 605 -15B-57	600/1A	15	1.0	57
RESIN CAST TERMINAL				
MRT 301 -5B-57	300/1A	5	1.0	57
MRT 301 -10B-57	300/1A	10	1.0	57
MRT 401 -5B-57	400/1A	5	1.0	57
MRT 401 -10B-57	400/1A	10	1.0	57
MRT 501 -5B-57	500/1A	5	1.0	57
MRT 501 -10B-57	500/1A	10	1.0	57
MRT 601 -10B-57	600/1A	10	1.0	57
MRT 601 -15B-57	600/1A	15	1.0	57

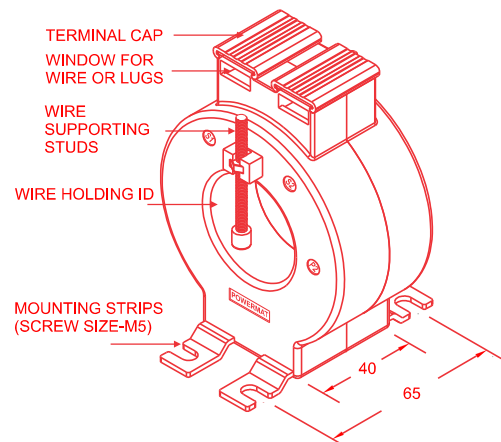
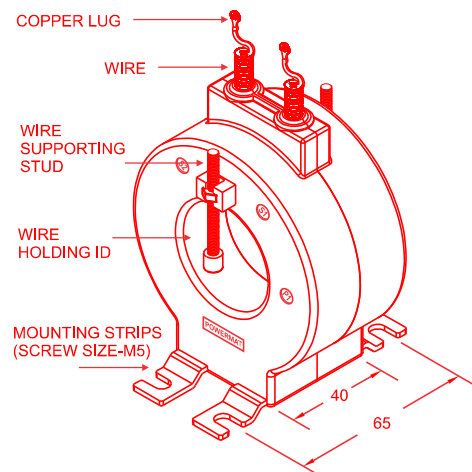

All Dimensions are in MM • Above Current Transformers are **CE** certified.
All above mentioned CT are also available in Class 0.5, Class 3, Class 5.
Please contact your local POWERMAT sales representative for more information.

Current Transformers Resin Cast

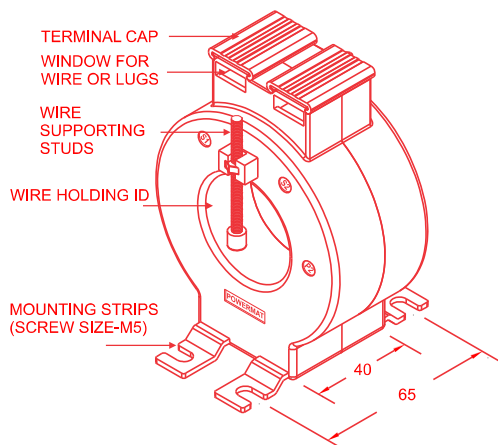
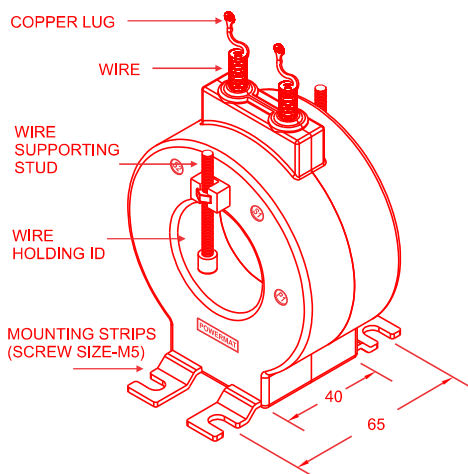
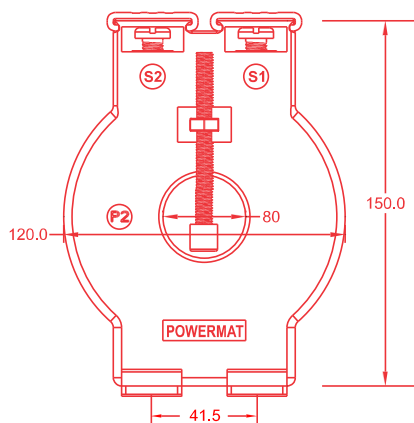

Ring Type Metering Current Transformers Resin Cast Secondary : 5A, ID : 80mm

Section : MTR 5.1

Accuracy Class : 1.0

Product Code	Ratio	Burden	Class	ID
RESIN CAST WIRE				
MRW 505 -5B-80	500/5A	5	1.0	80
MRW 505 -10B-80	500/5A	10	1.0	80
MRW 605 -5B-80	600/5A	5	1.0	80
MRW 605 -10B-80	600/5A	10	1.0	80
MRW 805 -10B-80	800/5A	10	1.0	80
MRW 805 -15B-80	800/5A	15	1.0	80
MRW 1005 -10B-80	1000/5A	10	1.0	80
MRW 1005 -15B-80	1000/5A	15	1.0	80

Product Code	Ratio	Burden	Class	ID
RESIN CAST TERMINAL				
MRT 505 -5B-80	500/5A	5	1.0	80
MRT 505 -10B-80	500/5A	10	1.0	80
MRT 605 -5B-80	600/5A	5	1.0	80
MRT 605 -10B-80	600/5A	10	1.0	80
MRT 805 -10B-80	800/5A	10	1.0	80
MRT 805 -15B-80	800/5A	15	1.0	80
MRT 1005 -10B-80	1000/5A	10	1.0	80
MRT 1005 -15B-80	1000/5A	15	1.0	80

Ring Type Metering Current Transformers Resin Cast Secondary : 1A, ID : 80mm

Section : MTR 5.2

Accuracy Class : 1.0

Product Code	Ratio	Burden	Class	ID
RESIN CAST WIRE				
MRW 501 -5B-80	500/1A	5	1.0	80
MRW 501 -10B-80	500/1A	10	1.0	80
MRW 601 -5B-80	600/1A	5	1.0	80
MRW 601 -10B-80	600/1A	10	1.0	80
MRW 801 -10B-80	800/1A	10	1.0	80
MRW 801 -15B-80	800/1A	15	1.0	80
MRW 1001 -10B-80	1000/1A	10	1.0	80
MRW 1001 -15B-80	1000/1A	15	1.0	80

Product Code	Ratio	Burden	Class	ID
RESIN CAST TERMINAL				
MRT 501 -5B-80	500/1A	5	1.0	80
MRT 501 -10B-80	500/1A	10	1.0	80
MRT 601 -5B-80	600/1A	5	1.0	80
MRT 601 -10B-80	600/1A	10	1.0	80
MRT 801 -10B-80	800/1A	10	1.0	80
MRT 801 -15B-80	800/1A	15	1.0	80
MRT 1001 -10B-80	1000/1A	10	1.0	80
MRT 1001 -15B-80	1000/1A	15	1.0	80

All Dimensions are in MM • Above Current Transformers are CE certified.

All above mentioned CT are also available in Class 0.5, Class 3, Class 5.

Please contact your local POWERMAT sales representative for more information.

POWERMAT.....

**Ring Type Metering Current Transformers Resin Cast
Secondary : 5A, ID : 110mm**

Section : MTR 6.1

Accuracy Class : 1.0

Product Code	Ratio	Burden	Class	ID
RESIN CAST WIRE				
MRW 1205 -10B-110	1200/5A	10	1.0	110
MRW 1205 -15B-110	1200/5A	15	1.0	110
MRW 1605 -10B-110	1600/5A	10	1.0	110
MRW 1605 -15B-110	1600/5A	15	1.0	110
MRW 2005 -10B-110	2000/5A	10	1.0	110
MRW 2005 -15B-110	2000/5A	15	1.0	110
MRW 2505 -10B-110	2500/5A	10	1.0	110
MRW 2505 -15B-110	2500/5A	15	1.0	110
RESIN CAST TERMINAL				
MRT 1205 -10B-110	1200/5A	10	1.0	110
MRT 1205 -15B-110	1200/5A	15	1.0	110
MRT 1605 -10B-110	1600/5A	10	1.0	110
MRT 1605 -15B-110	1600/5A	15	1.0	110
MRT 2005 -10B-110	2000/5A	10	1.0	110
MRT 2005 -15B-110	2000/5A	15	1.0	110
MRT 2505 -10B-110	2500/5A	10	1.0	110
MRT 2505 -15B-110	2500/5A	15	1.0	110

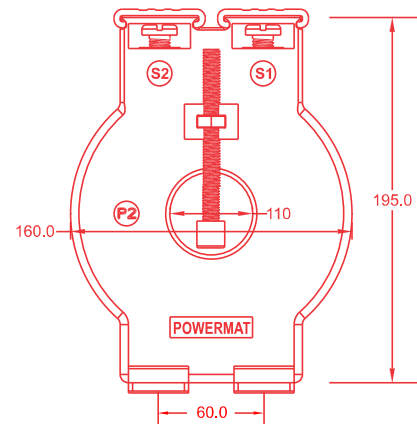

**Ring Type Metering Current Transformers Resin Cast
Secondary : 1A, ID : 110mm**

Section : MTR 6.2

Accuracy Class : 1.0

Product Code	Ratio	Burden	Class	ID
RESIN CAST WIRE				
MRW 1201 -10B-110	1200/1A	10	1.0	110
MRW 1201 -15B-110	1200/1A	15	1.0	110
MRW 1601 -10B-110	1600/1A	10	1.0	110
MRW 1601 -15B-110	1600/1A	15	1.0	110
MRW 2001 -10B-110	2000/1A	10	1.0	110
MRW 2001 -15B-110	2000/1A	15	1.0	110
MRW 2501 -10B-110	2500/1A	10	1.0	110
MRW 2501 -15B-110	2500/1A	15	1.0	110
RESIN CAST TERMINAL				
MRT 1201 -10B-110	1200/1A	10	1.0	110
MRT 1201 -15B-110	1200/1A	15	1.0	110
MRT 1601 -10B-110	1600/1A	10	1.0	110
MRT 1601 -15B-110	1600/1A	15	1.0	110
MRT 2001 -10B-110	2000/1A	10	1.0	110
MRT 2001 -15B-110	2000/1A	15	1.0	110
MRT 2501 -10B-110	2500/1A	10	1.0	110
MRT 2501 -15B-110	2500/1A	15	1.0	110

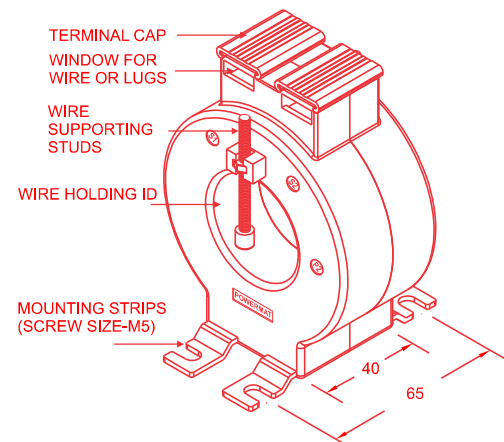
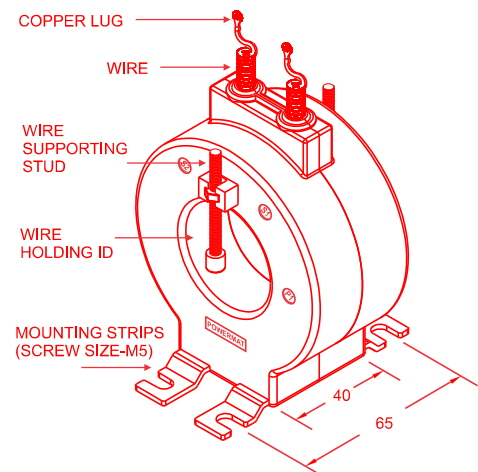

All Dimensions are in MM • Above Current Transformers are **CE** certified.
All above mentioned CT are also available in Class 0.5, Class 3, Class 5.
Please contact your local POWERMAT sales representative for more information.

Current Transformers



Rectangular Type Metering Current Transformers Secondary : 5A, ID : 60/25mm

Section : RC 1.1

Accuracy Class : 1.0

Product Code	Ratio	Burden	Class	ID
TERMINAL TYPE				
MTS 205 -5B-60/25	200/5A	5	1.0	60/25
MTS 205 -10B-60/25	200/5A	10	1.0	60/25
MTS 255 -5B-60/25	250/5A	5	1.0	60/25
MTS 255 -10B-60/25	250/5A	10	1.0	60/25
MTS 305 -5B-60/25	300/5A	5	1.0	60/25
MTS 305 -10B-60/25	300/5A	10	1.0	60/25
MTS 405 -10B-60/25	400/5A	10	1.0	60/25
MTS 505-10B-60/25	500/5A	10	1.0	60/25

Rectangular Type Metering Current Transformers Secondary : 1A, ID : 60/25mm

Section : RC 1.2

Accuracy Class : 1.0

Product Code	Ratio	Burden	Class	ID
TERMINAL TYPE				
MTS 201 -5B-60/25	200/1A	5	1.0	60/25
MTS 201 -10B-60/25	200/1A	10	1.0	60/25
MTS 251 -5B-60/25	250/1A	5	1.0	60/25
MTS 251 -10B-60/25	250/1A	10	1.0	60/25
MTS 301 -5B-60/25	300/1A	5	1.0	60/25
MTS 301 -10B-60/25	300/1A	10	1.0	60/25
MTS 401 -10B-60/25	400/1A	10	1.0	60/25
MTS 501-10B-60/25	500/1A	10	1.0	60/25

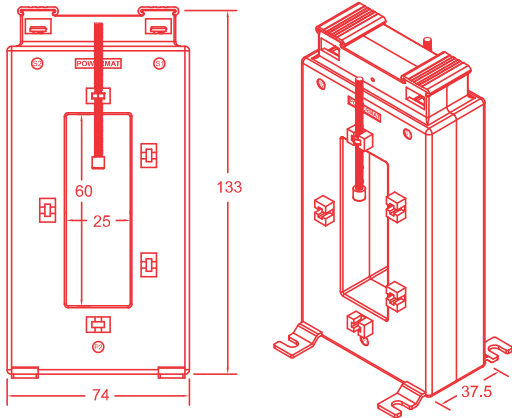

Rectangular Type Metering Current Transformers Secondary : 5A, ID : 105/35mm

Section : RC 2.1

Accuracy Class : 1.0

Product Code	Ratio	Burden	Class	ID
TERMINAL TYPE				
MTS 505-10B-105/35	500/5A	10	1.0	105/35
MTS 605-10B-105/35	600/5A	10	1.0	105/35
MTS 805-10B-105/35	800/5A	10	1.0	105/35
MTS 805-15B-105/35	800/5A	15	1.0	105/35
MTS 1005-10B-105/35	1000/5A	10	1.0	105/35
MTS 1005-15B-105/35	1000/5A	15	1.0	105/35
MTS 1205-15B-105/35	1200/5A	15	1.0	105/35
MTS 1505-15B-105/35	1500/5A	15	1.0	105/35

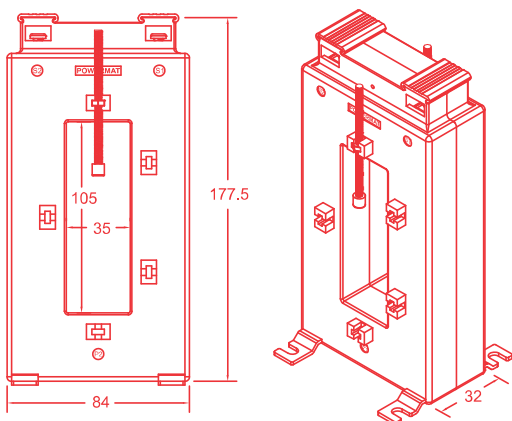

Rectangular Type Metering Current Transformers Secondary : 1A, ID : 105/35mm

Section : RC 2.2

Accuracy Class : 1.0

Product Code	Ratio	Burden	Class	ID
TERMINAL TYPE				
MTS 501-10B-105/35	500/1A	10	1.0	105/35
MTS 601-10B-105/35	600/1A	10	1.0	105/35
MTS 801-10B-105/35	800/1A	10	1.0	105/35
MTS 801-15B-105/35	800/1A	15	1.0	105/35
MTS 1001-10B-105/35	1000/1A	10	1.0	105/35
MTS 1001-15B-105/35	1000/1A	15	1.0	105/35
MTS 1201-15B-105/35	1200/1A	15	1.0	105/35
MTS 1501-15B-105/35	1500/1A	15	1.0	105/35

All Dimensions are in MM • Above Current Transformers are **CE** certified.

All above mentioned CT are also available in Class 0.5, Class 3, Class 5.

Please contact your local POWERMAT sales representative for more information.

POWERMAT.....

**Rectangular Type Metering Current Transformers
Secondary : 5A, ID : 155/50mm**

Section : RC 3.1 Accuracy Class : 1.0

Product Code	Ratio	Burden	Class	ID
TERMINAL TYPE				
MTS 1505-15B-155/50	1500/5A	15	1.0	155/50
MTS 1605-15B-155/50	1600/5A	15	1.0	155/50
MTS 2005-15B-155/50	2000/5A	15	1.0	155/50
MTS 2505-15B-155/50	2500/5A	15	1.0	155/50
MTS 3005-15B-155/50	3000/5A	15	1.0	155/50
MTS 3205-15B-155/50	3200/5A	15	1.0	155/50
MTS 4005-15B-155/50	4000/5A	15	1.0	155/50



**Rectangular Type Metering Current Transformers
Secondary : 1A, ID : 155/50mm**

Section : RC 3.2 Accuracy Class : 1.0

Product Code	Ratio	Burden	Class	ID
TERMINAL TYPE				
MTS 1501-15B-155/50	1500/1A	15	1.0	155/50
MTS 1601-15B-155/50	1600/1A	15	1.0	155/50
MTS 2001-15B-155/50	2000/1A	15	1.0	155/50
MTS 2501-15B-155/50	2500/1A	15	1.0	155/50
MTS 3001-15B-155/50	3000/1A	15	1.0	155/50
MTS 3201-15B-155/50	3200/1A	15	1.0	155/50
MTS 4001-15B-155/50	4000/1A	15	1.0	155/50

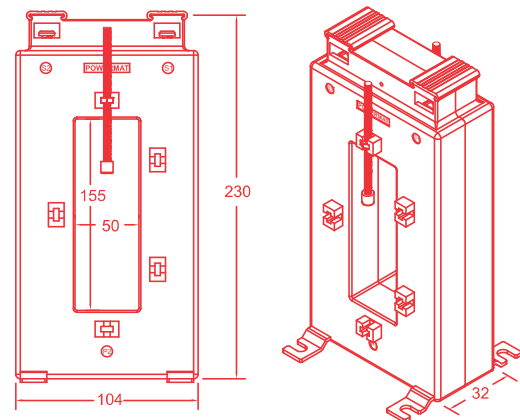

**Rectangular Type Metering Current Transformers
Secondary : 5A, ID : 170/90mm**

Section : RC 4.1 Accuracy Class : 1.0

Product Code	Ratio	Burden	Class	ID
TERMINAL TYPE				
MTS 2505-15B-170/90	2500/5A	15	1.0	170/90
MTS 3005-15B-170/90	3000/5A	15	1.0	170/90
MTS 3205-15B-170/90	3200/5A	15	1.0	170/90
MTS 4005-15B-170/90	4000/5A	15	1.0	170/90
MTS 5005-15B-170/90	5000/5A	15	1.0	170/90

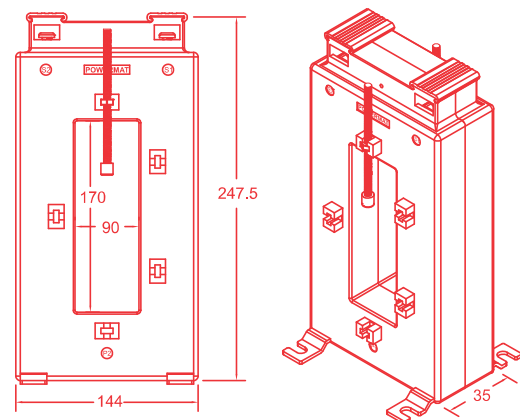

**Rectangular Type Metering Current Transformers
Secondary : 1A, ID : 170/90mm**

Section : RC 4.2 Accuracy Class : 1.0

Product Code	Ratio	Burden	Class	ID
TERMINAL TYPE				
MTS 2501-15B-170/90	2500/1A	15	1.0	170/90
MTS 3001-15B-170/90	3000/1A	15	1.0	170/90
MTS 3201-15B-170/90	3200/1A	15	1.0	170/90
MTS 4001-15B-170/90	4000/1A	15	1.0	170/90
MTS 5001-15B-170/90	5000/1A	15	1.0	170/90

All Dimensions are in MM • Above Current Transformers are **CE** certified.
All above mentioned CT are also available in Class 0.5, Class 3, Class 5.
Please contact your local POWERMAT sales representative for more information.

Current Transformers



Resin Cast Rectangular Type Metering Current Transformers Secondary : 5A, ID : 60/25mm

Section : RC 1.1

Accuracy Class : 1.0

Product Code	Ratio	Burden	Class	ID
TERMINAL TYPE				
MRS 205 -5B-60/25	200/5A	5	1.0	60/25
MRS 205 -10B-60/25	200/5A	10	1.0	60/25
MRS 255 -5B-60/25	250/5A	5	1.0	60/25
MRS 255 -10B-60/25	250/5A	10	1.0	60/25
MRS 305 -5B-60/25	300/5A	5	1.0	60/25
MRS 305 -10B-60/25	300/5A	10	1.0	60/25
MRS 405 -10B-60/25	400/5A	10	1.0	60/25
MRS 505-10B-60/25	500/5	10	1.0	60/25

Rectangular Type Metering Current Transformers Secondary : 1A, ID : 60/25mm

Section : RC 1.2

Accuracy Class : 1.0

Product Code	Ratio	Burden	Class	ID
TERMINAL TYPE				
MRS 201 -5B-60/25	200/1A	5	1.0	60/25
MRS 201 -10B-60/25	200/1A	10	1.0	60/25
MRS 251 -5B-60/25	250/1A	5	1.0	60/25
MRS 251 -10B-60/25	250/1A	10	1.0	60/25
MRS 301 -5B-60/25	300/1A	5	1.0	60/25
MRS 301 -10B-60/25	300/1A	10	1.0	60/25
MRS 401 -10B-60/25	400/1A	10	1.0	60/25
MRS 501-10B-60/25	500/1A	10	1.0	60/25

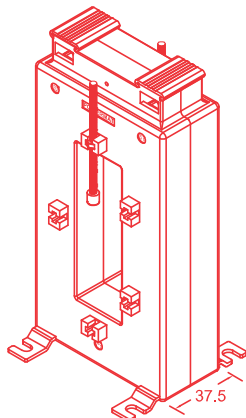
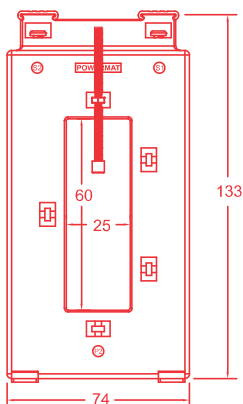

Rectangular Type Metering Current Transformers Secondary : 5A, ID : 105/35mm

Section : RC 2.1

Accuracy Class : 1.0

Product Code	Ratio	Burden	Class	ID
TERMINAL TYPE				
MRS 505-10B-105/35	500/5A	10	1.0	105/35
MRS 605-10B-105/35	600/5A	10	1.0	105/35
MRS 805-10B-105/35	800/5A	10	1.0	105/35
MRS 805-15B-105/35	800/5A	15	1.0	105/35
MRS 1005-10B-105/35	1000/5A	10	1.0	105/35
MRS 1005-15B-105/35	1000/5A	15	1.0	105/35
MRS 1205-15B-105/35	1200/5A	15	1.0	105/35
MRS 1505-15B-105/35	1500/5A	15	1.0	105/35

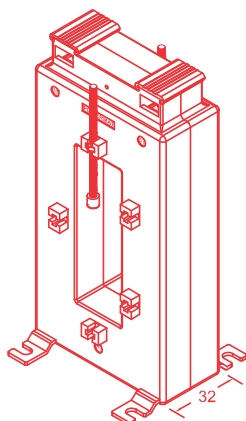
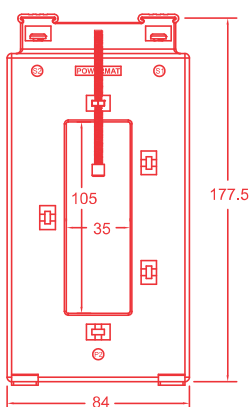

Rectangular Type Metering Current Transformers Secondary : 1A, ID : 105/35mm

Section : RC 2.2

Accuracy Class : 1.0

Product Code	Ratio	Burden	Class	ID
TERMINAL TYPE				
MRS 501-10B-105/35	500/1A	10	1.0	105/35
MRS 601-10B-105/35	600/1A	10	1.0	105/35
MRS 801-10B-105/35	800/1A	10	1.0	105/35
MRS 801-15B-105/35	800/1A	15	1.0	105/35
MRS 1001-10B-105/35	1000/1A	10	1.0	105/35
MRS 1001-15B-105/35	1000/1A	15	1.0	105/35
MRS 1201-15B-105/35	1200/1A	15	1.0	105/35
MRS 1501-15B-105/35	1500/1A	15	1.0	105/35

All Dimensions are in MM • Above Current Transformers are CE certified.

All above mentioned CT are also available in Class 0.5, Class 3, Class 5.

Please contact your local POWERMAT sales representative for more information.

POWERMAT

Rectangular Type Metering Current Transformers Secondary : 5A, ID : 155/50mm

Section : RC 3.1

Accuracy Class : 1.0

Product Code	Ratio	Burden	Class	ID
TERMINAL TYPE				
MRS 1505-15B-155/50	1500/5A	15	1.0	155/50
MRS 1605-15B-155/50	1600/5A	15	1.0	155/50
MRS 2005-15B-155/50	2000/5A	15	1.0	155/50
MRS 2505-15B-155/50	2500/5A	15	1.0	155/50
MRS 3005-15B-155/50	3000/5A	15	1.0	155/50
MRS 3205-15B-155/50	3200/5A	15	1.0	155/50
MRS 4005-15B-155/50	4000/5A	15	1.0	155/50



Rectangular Type Metering Current Transformers Secondary : 1A, ID : 155/50mm

Section : RC 3.2

Accuracy Class : 1.0

Product Code	Ratio	Burden	Class	ID
TERMINAL TYPE				
MRS 1501-15B-155/50	1500/1A	15	1.0	155/50
MRS 1601-15B-155/50	1600/1A	15	1.0	155/50
MRS 2001-15B-155/50	2000/1A	15	1.0	155/50
MRS 2501-15B-155/50	2500/1A	15	1.0	155/50
MRS 3001-15B-155/50	3000/1A	15	1.0	155/50
MRS 3201-15B-155/50	3200/1A	15	1.0	155/50
MRS 4001-15B-155/50	4000/1A	15	1.0	155/50

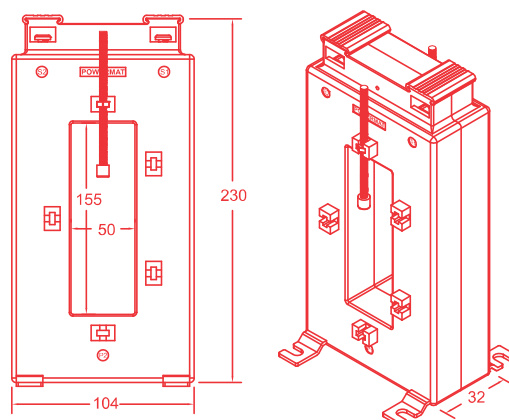

Rectangular Type Metering Current Transformers Secondary : 5A, ID : 170/90mm

Section : RC 4.1

Accuracy Class : 1.0

Product Code	Ratio	Burden	Class	ID
TERMINAL TYPE				
MRS 2505-15B-170/90	2500/5A	15	1.0	170/90
MRS 3005-15B-170/90	3000/5A	15	1.0	170/90
MRS 3205-15B-170/90	3200/5A	15	1.0	170/90
MRS 4005-15B-170/90	4000/5A	15	1.0	170/90
MRS 5005-15B-170/90	5000/5A	15	1.0	170/90

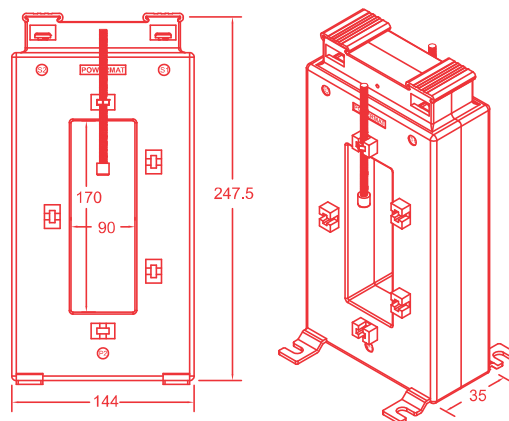

Rectangular Type Metering Current Transformers Secondary : 1A, ID : 170/90mm

Section : RC 4.2

Accuracy Class : 1.0

Product Code	Ratio	Burden	Class	ID
TERMINAL TYPE				
MRS 2501-15B-170/90	2500/1A	15	1.0	170/90
MRS 3001-15B-170/90	3000/1A	15	1.0	170/90
MRS 3201-15B-170/90	3200/1A	15	1.0	170/90
MRS 4001-15B-170/90	4000/1A	15	1.0	170/90
MRS 5001-15B-170/90	5000/1A	15	1.0	170/90

All Dimensions are in MM • Above Current Transformers are **CE** certified.
All above mentioned CT are also available in Class 0.5
Please contact your local POWERMAT sales representative for more information.

Current Transformers



Ring Type Protection Current Transformers Secondary : 5A, ID : 43mm

Section : PC 1.1

Accuracy Class : 5P10

Product Code	Ratio	Burden	Class	ID
TERMINAL TYPE				
PTT 105 -10D-43	100/5A	10	5P10	43
PTT 155 -10D-43	150/5A	10	5P10	43
PTT 205 -10D-43	200/5A	10	5P10	43
PTT 255 -10D-43	250/5A	10	5P10	43
PTT 305 -10D-43	300/5A	10	5P10	43
PTT 405 -10D-43	400/5A	10	5P10	43

Ring Type Protection Current Transformers Secondary : 1A, ID : 43mm

Section : PC 1.2

Accuracy Class : 5P10

Product Code	Ratio	Burden	Class	ID
TERMINAL TYPE				
PTT 101 -10D-43	100/1A	10	5P10	43
PTT 151 -10D-43	150/1A	10	5P10	43
PTT 201 -10D-43	200/1A	10	5P10	43
PTT 251 -10D-43	250/1A	10	5P10	43
PTT 301 -10D-43	300/1A	10	5P10	43
PTT 401 -10D-43	400/1A	10	5P10	43

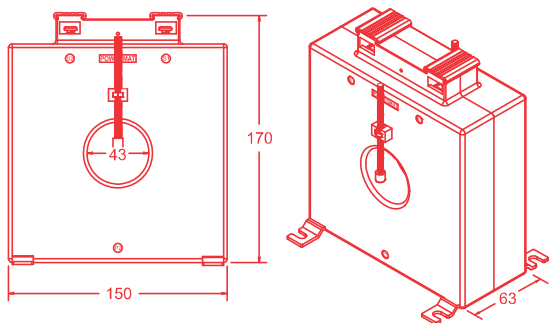

Rectangular Type Protection Current Transformers Secondary : 5A, ID : 105/35mm

Section : PC 2.1

Accuracy Class : 5P10

Product Code	Ratio	Burden	Class	ID
TERMINAL TYPE				
PTS 505 -10D-105/35	500/5A	10	5P10	105/35
PTS 605 -10D-105/35	600/5A	10	5P10	105/35
PTS 805 -15D-105/35	800/5A	15	5P10	105/35
PTS 1005 -15D-105/35	1000/5A	15	5P10	105/35
PTS 1205 -15D-105/35	1200/5A	15	5P10	105/35
PTS 1255 -15D-105/35	1250/5A	15	5P10	105/35
PTS 1505 -15D-105/35	1500/5A	15	5P10	105/35
PTS 1605 -15D-105/35	1600/5A	15	5P10	105/35

Rectangular Type Protection Current Transformers Secondary : 1A, ID : 105/35mm

Section : PC 2.2

Accuracy Class : 5P10

Product Code	Ratio	Burden	Class	ID
TERMINAL TYPE				
PTS 501 -10D-105/35	500/1A	10	5P10	105/35
PTS 601 -10D-105/35	600/1A	10	5P10	105/35
PTS 801 -15D-105/35	800/1A	15	5P10	105/35
PTS 1001 -15D-105/35	1000/1A	15	5P10	105/35
PTS 1201 -15D-105/35	1200/1A	15	5P10	105/35
PTS 1251 -15D-105/35	1250/1A	15	5P10	105/35
PTS 1501 -15D-105/35	1500/1A	15	5P10	105/35
PTS 1601 -15D-105/35	1600/1A	15	5P10	105/35

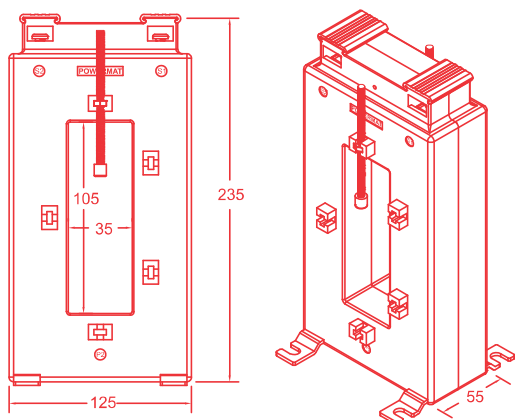

All Dimensions are in MM • Above Current Transformers are CE certified.
All Current Transformers available in 5P5 & 5P15

Rectangular Type Protection Current Transformers Secondary : 5A, ID : 155/50mm

Section : PC 3.1

Accuracy Class : 5P10

Product Code	Ratio	Burden	Class	ID
TERMINAL TYPE				
PTS 1505 -15D-155/50	1500/5A	15	5P10	155/50
PTS 1605 -15D-155/50	1600/5A	15	5P10	155/50
PTS 2005 -15D-155/50	2000/5A	15	5P10	155/50
PTS 2505 -15D-155/50	2500/5A	15	5P10	155/50
PTS 3005 -15D-155/50	3000/5A	15	5P10	155/50
PTS 3205 -15D-155/50	3200/5A	15	5P10	155/50
PTS 4005 -15D-155/50	4000/5A	15	5P10	155/50

Rectangular Type Protection Current Transformers Secondary : 1A, ID : 155/50mm

Section : PC 3.2

Accuracy Class : 5P10

Product Code	Ratio	Burden	Class	ID
TERMINAL TYPE				
PTS 1501 -15D-155/50	1500/1A	15	5P10	155/50
PTS 1601 -15D-155/50	1600/1A	15	5P10	155/50
PTS 2001 -15D-155/50	2000/1A	15	5P10	155/50
PTS 2501 -15D-155/50	2500/1A	15	5P10	155/50
PTS 3001 -15D-155/50	3000/1A	15	5P10	155/50
PTS 3201 -15D-155/50	3200/1A	15	5P10	155/50
PTS 4001 -15D-155/50	4000/1A	15	5P10	155/50

Rectangular Type Protection Current Transformers Secondary : 5A, ID : 170/90mm

Section : PC 4.1

Accuracy Class : 5P10

Product Code	Ratio	Burden	Class	ID
TERMINAL TYPE				
PTS 2505-15D-170/90	2500/5A	15	5P10	170/90
PTS 3005-15D-170/90	3000/5A	15	5P10	170/90
PTS 3205-15D-170/90	3200/5A	15	5P10	170/90
PTS 4005-15D-170/90	4000/5A	15	5P10	170/90
PTS 5005-15D-170/90	5000/5A	15	5P10	170/90

Rectangular Type Protection Current Transformers Secondary : 1A, ID : 170/90mm

Section : PC 4.2

Accuracy Class : 5P10

Product Code	Ratio	Burden	Class	ID
TERMINAL TYPE				
PTS 2501-15D-170/90	2500/1A	15	5P10	170/90
PTS 3001-15D-170/90	3000/1A	15	5P10	170/90
PTS 3201-15D-170/90	3200/1A	15	5P10	170/90
PTS 4001-15D-170/90	4000/1A	15	5P10	170/90
PTS 5001-15D-170/90	5000/1A	15	5P10	170/90

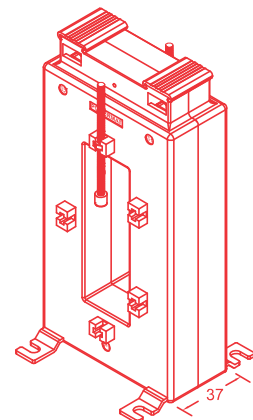
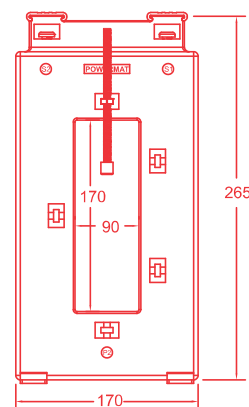
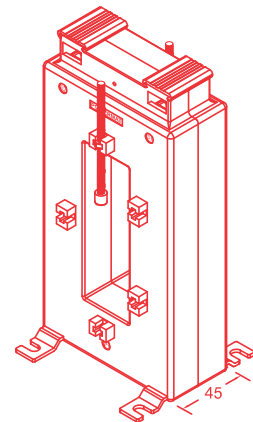
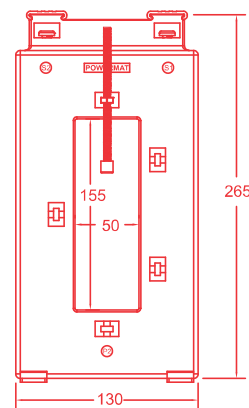

All Dimensions are in MM • Above Current Transformers are certified.
All Current Transformers available in 5P5, 5P15, 5P20 & PS

Current Transformers

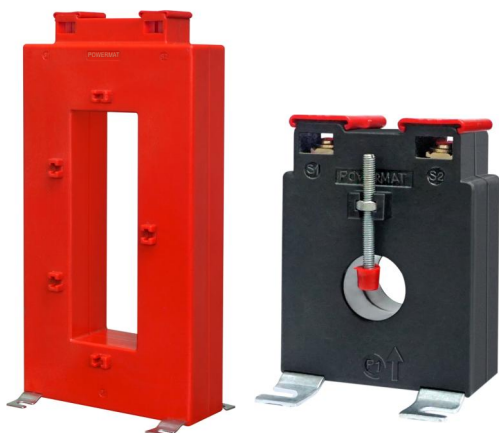

Ring Type RESIN Protection Current Transformers Secondary : 5A, ID : 43mm

Section : PC 1.1

Accuracy Class : 5P10

Product Code	Ratio	Burden	Class	ID
TERMINAL TYPE				
PRT 105 -10D-43	100/5A	10	5P10	43
PRT 155 -10D-43	150/5A	10	5P10	43
PRT 205 -10D-43	200/5A	10	5P10	43
PRT 255 -10D-43	250/5A	10	5P10	43
PRT 305 -10D-43	300/5A	10	5P10	43
PRT 405 -10D-43	400/5A	10	5P10	43

Ring Type RESIN Protection Current Transformers Secondary : 1A, ID : 43mm

Section : PC 1.2

Accuracy Class : 5P10

Product Code	Ratio	Burden	Class	ID
TERMINAL TYPE				
PRT 101 -10D-43	100/1A	10	5P10	43
PRT 151 -10D-43	150/1A	10	5P10	43
PRT 201 -10D-43	200/1A	10	5P10	43
PRT 251 -10D-43	250/1A	10	5P10	43
PRT 301 -10D-43	300/1A	10	5P10	43
PRT 401 -10D-43	400/1A	10	5P10	43

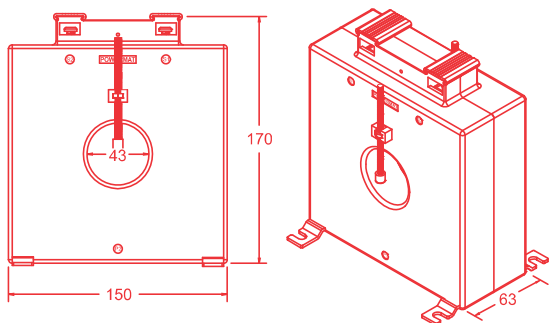

Rectangular RESIN Type Protection Current Transformers Secondary : 5A, ID : 105/35mm

Section : PC 2.1

Accuracy Class : 5P10

Product Code	Ratio	Burden	Class	ID
TERMINAL TYPE				
PRS 505 -10D-105/35	500/5A	10	5P10	105/35
PRS 605 -10D-105/35	600/5A	10	5P10	105/35
PRS 805 -15D-105/35	800/5A	15	5P10	105/35
PRS 1005 -15D-105/35	1000/5A	15	5P10	105/35
PRS 1205 -15D-105/35	1200/5A	15	5P10	105/35
PRS 1255 -15D-105/35	1250/5A	15	5P10	105/35
PRS 1505 -15D-105/35	1500/5A	15	5P10	105/35
PRS 1605 -15D-105/35	1600/5A	15	5P10	105/35

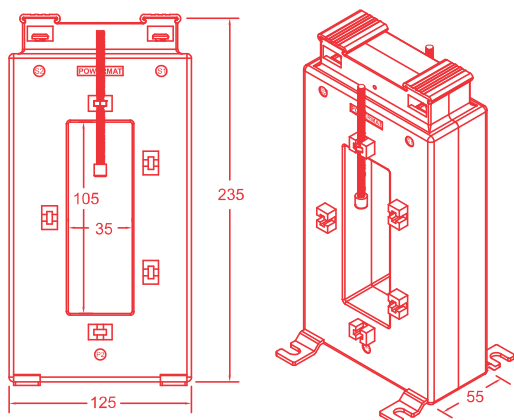

Rectangular RESIN Type Protection Current Transformers Secondary : 1A, ID : 105/35mm

Section : PC 2.2

Accuracy Class : 5P10

Product Code	Ratio	Burden	Class	ID
TERMINAL TYPE				
PRS 501 -10D-105/35	500/1A	10	5P10	105/35
PRS 601 -10D-105/35	600/1A	10	5P10	105/35
PRS 801 -15D-105/35	800/1A	15	5P10	105/35
PRS 1001 -15D-105/35	1000/1A	15	5P10	105/35
PRS 1201 -15D-105/35	1200/1A	15	5P10	105/35
PRS 1251 -15D-105/35	1250/1A	15	5P10	105/35
PRS 1501 -15D-105/35	1500/1A	15	5P10	105/35
PRS 1601 -15D-105/35	1600/1A	15	5P10	105/35

All Dimensions are in MM • Above Current Transformers are CE certified.
All Current Transformers available in 5P5, 5P15, 5P20 & PS

Rectangular RESIN Type Protection Current Transformers Secondary : 5A, ID : 155/50mm

Section : PC 3.1

Accuracy Class : 5P10

Product Code	Ratio	Burden	Class	ID
TERMINAL TYPE				
PRS 1505 -15D-155/50	1500/5A	15	5P10	155/50
PRS 1605 -15D-155/50	1600/5A	15	5P10	155/50
PRS 2005 -15D-155/50	2000/5A	15	5P10	155/50
PRS 2505 -15D-155/50	2500/5A	15	5P10	155/50
PRS 3005 -15D-155/50	3000/5A	15	5P10	155/50
PRS 3205 -15D-155/50	3200/5A	15	5P10	155/50
PRS 4005 -15D-155/50	4000/5A	15	5P10	155/50



Rectangular RESIN Type Protection Current Transformers Secondary : 1A, ID : 155/50mm

Section : PC 3.2

Accuracy Class : 5P10

Product Code	Ratio	Burden	Class	ID
TERMINAL TYPE				
PRS 1501 -15D-155/50	1500/1A	15	5P10	155/50
PRS 1601 -15D-155/50	1600/1A	15	5P10	155/50
PRS 2001 -15D-155/50	2000/1A	15	5P10	155/50
PRS 2501 -15D-155/50	2500/1A	15	5P10	155/50
PRS 3001 -15D-155/50	3000/1A	15	5P10	155/50
PRS 3201 -15D-155/50	3200/1A	15	5P10	155/50
PRS 4001 -15D-155/50	4000/1A	15	5P10	155/50

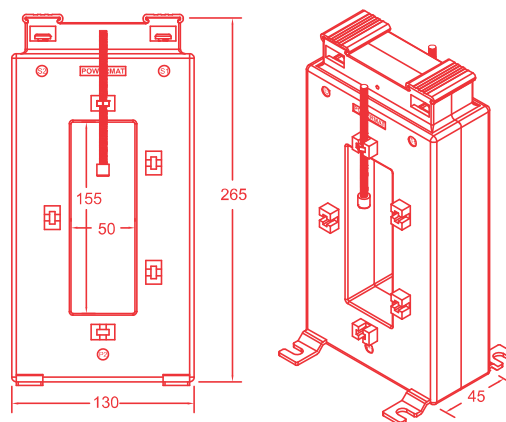

Rectangular RESIN Type Protection Current Transformers Secondary : 5A, ID : 170/90mm

Section : PC 4.1

Accuracy Class : 5P10

Product Code	Ratio	Burden	Class	ID
TERMINAL TYPE				
PRS 2505-15D-170/90	2500/5A	15	5P10	170/90
PRS 3005-15D-170/90	3000/5A	15	5P10	170/90
PRS 32005-15D-170/90	3200/5A	15	5P10	170/90
PRS 4005-15D-170/90	4000/5A	15	5P10	170/90
PRS 5005-15D-170/90	5000/5A	15	5P10	170/90

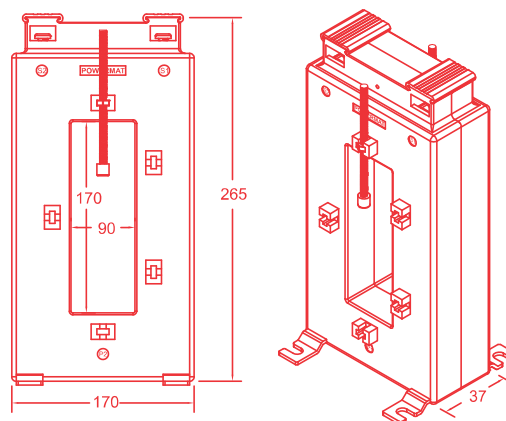

Rectangular RESIN Type Protection Current Transformers Secondary : 1A, ID : 170/90mm

Section : PC 4.2

Accuracy Class : 5P10

Product Code	Ratio	Burden	Class	ID
TERMINAL TYPE				
PRS 2501-15D-170/90	2500/1A	15	5P10	170/90
PRS 3001-15D-170/90	3000/1A	15	5P10	170/90
PRS 3201-15D-170/90	3200/1A	15	5P10	170/90
PRS 4001-15D-170/90	4000/1A	15	5P10	170/90
PRS 5001-15D-170/90	5000/1A	15	5P10	170/90

All Dimensions are in MM • Above Current Transformers are **CE** certified.
All Current Transformers available in 5P5, 5P15, 5P20 & PS

Current Transformers



Special Class Protection Current Transformers Secondary : 5A, ID : 105/35mm

Section : SP 1.1

Accuracy Class : PS

Product Code	Ratio	VK	Class	ID
TERMINAL TYPE				
PSC 805 -30V-105/35	800/5A	30	PS	105/35
PSC 1005 -35V-105/35	1000/5A	35	PS	105/35
PSC 1205 -35V-105/35	1200/5A	35	PS	105/35
PSC 1255 -40V-105/35	1250/5A	40	PS	105/35
PSC 1605 -45V-105/35	1600/5A	45	PS	105/35

Special Class Protection Current Transformers Secondary : 1A, ID : 105/35mm

Section : SP 1.2

Accuracy Class : PS

Product Code	Ratio	VK	Class	ID
TERMINAL TYPE				
PSC 801 -115V-105/35	800/1A	115	PS	105/35
PSC 1001 -140V-105/35	1000/1A	140	PS	105/35
PSC 1201 -170V-105/35	1200/1A	170	PS	105/35
PSC 1251 -180V-105/35	1250/1A	180	PS	105/35
PSC 1601 -220V-105/35	1600/1A	220	PS	105/35

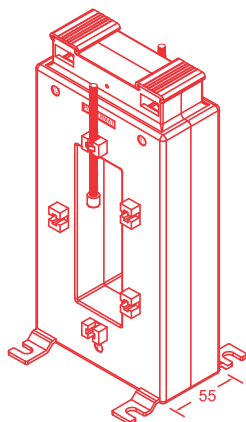
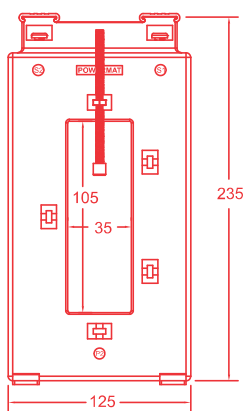

Special Class Protection Current Transformers Secondary : 5A, ID : 155/50mm

Section : SP 2.1

Accuracy Class : PS

Product Code	Ratio	VK	Class	ID
TERMINAL TYPE				
PSC 1605 -40V-155/50	1600/5A	40	PS	155/50
PSC 2005 -50V-155/50	2000/5A	50	PS	155/50
PSC 2505 -60V-155/50	800/5A	60	PS	155/50
PSC 3005 -70V-155/50	800/5A	70	PS	155/50
PSC 3205 -75V-155/50	800/5A	75	PS	155/50

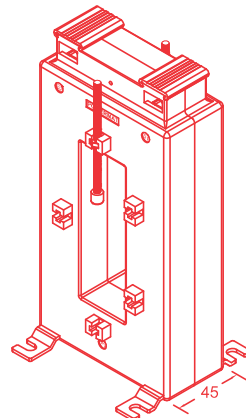
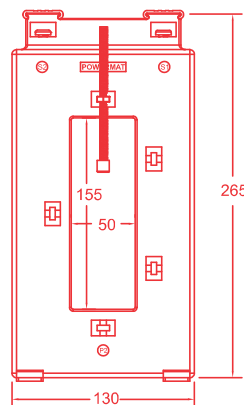

Special Class Protection Current Transformers Secondary : 1A, ID : 155/50mm

Section : SP 2.2

Accuracy Class : PS

Product Code	Ratio	VK	Class	ID
TERMINAL TYPE				
PSC 1601 -130V-155/50	1600/1A	130	PS	155/50
PSC 2001 -150V-155/50	2000/1A	150	PS	155/50
PSC 2501 -200V-155/50	2500/1A	200	PS	155/50
PSC 3001 -230V-155/50	3000/1A	230	PS	155/50
PSC 3201 -250V-155/50	3200/1A	250	PS	155/50

Special Class Protection Current Transformers Secondary : 5A, ID : 170/90mm

Section : SP 3.1

Accuracy Class : PS

Product Code	Ratio	VK	Class	ID
TERMINAL TYPE				
PSC 2505 -40V-170/90	2500/5A	40	PS	170/90
PSC 3005 -50V-170/90	3000/5A	50	PS	170/90
PSC 3205 -60V-170/90	3200/5A	60	PS	170/90
PSC 4005 -70V-170/90	4000/5A	70	PS	170/90
PSC 5005 -75V-170/90	5000/5A	75	PS	170/90

Special Class Protection Current Transformers Secondary : 1A, ID : 170/90mm

Section : SP 3.2

Accuracy Class : PS

Product Code	Ratio	VK	Class	ID
TERMINAL TYPE				
PSC 2501 -200V-170/90	2500/1A	200	PS	170/90
PSC 3001 -230V-170/90	3000/1A	230	PS	170/90
PSC 3201 -250V-170/90	3200/1A	250	PS	170/90
PSC 4001 -260V-170/90	4000/1A	260	PS	170/90
PSC 5001 -270V-170/90	5000/1A	270	PS	170/90

Primary Wound Type Metering Current Transformers Secondary : 5A

Section : WL 1.1

Accuracy Class : 1.0

Product Code	Ratio	Burden	Class
WPL 10 -5B	5/5A	5	1.0
WPL 15 -5B	10/5A	5	1.0
WPL 20 -5B	15/5A	5	1.0
WPL 25 -5B	20/5A	5	1.0
WPL 30 -5B	25/5A	5	1.0
WPL 35 -5B	30/5A	5	1.0
WPL 45 -5B	40/5A	5	1.0
WPL 55 -5B	55/5A	5	1.0
WPL 65 -5B	60/5A	5	1.0

Primary Wound Type Metering Current Transformers Secondary : 1A

Section : WL 1.2

Accuracy Class : 1.0

Product Code	Ratio	Burden	Class
WPL 6 -5B	5/1A	5	1.0
WPL 11 -5B	10/1A	5	1.0
WPL 16 -5B	15/5A	5	1.0
WPL 21 -5B	20/1A	5	1.0
WPL 26 -5B	25/1A	5	1.0
WPL 31 -5B	30/1A	5	1.0
WPL 41 -5B	40/1A	5	1.0
WPL 51 -5B	55/1A	5	1.0
WPL 61 -5B	60/1A	5	1.0

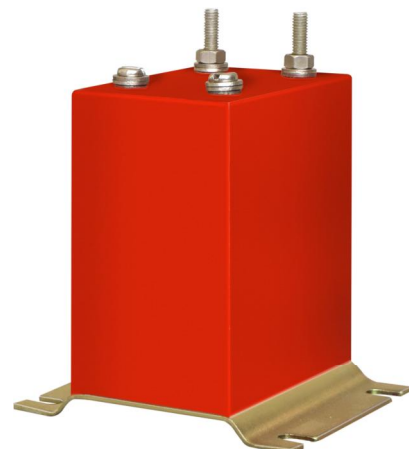
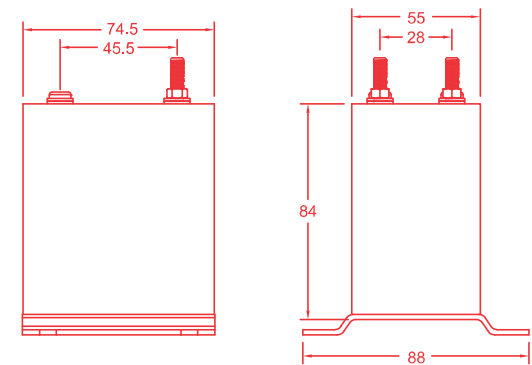
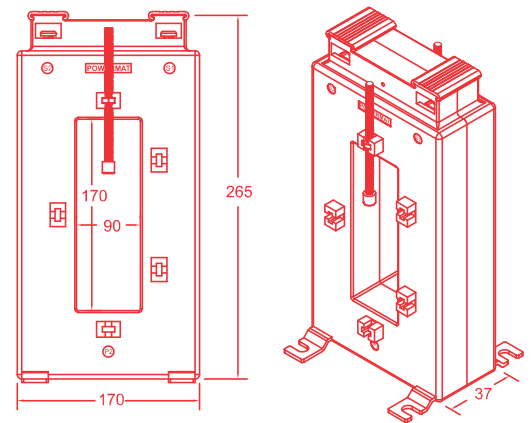

Current Transformers

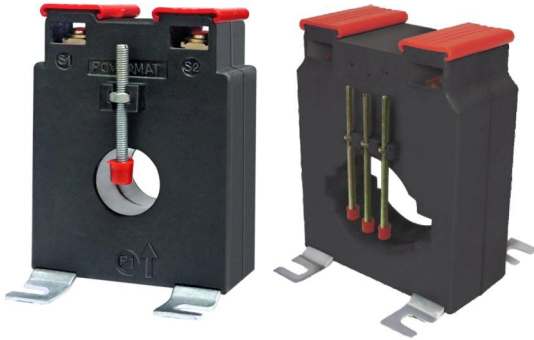

Moulded Case Metering Current Transformers Secondary : 5A, ID : 20mm

Section : MC 1.1

Accuracy Class : 1.0

Product Code	Ratio	Burden	Class	ID
TERMINAL TYPE				
MNB 30-5B-20-(4T)	25/5A	5	1.0	20
MNB 35-5B-20-(4T)	30/5A	5	1.0	20
MNB 45-5B-20-2T	40/5A	5	1.0	20
MNB 55-5B-20-2T	50/5A	5	1.0	20
MNB 65-5B-20-2T	60/5A	5	1.0	20
MNB 85-5B-20	80/5A	5	1.0	20
MNB 105-5B-20	100/5A	5	1.0	20
MNB 130-5B-20	125/5A	5	1.0	20
MNB 155-5B-20	150/5A	5	1.0	20

Moulded Case Metering Current Transformers Secondary : 1A, ID : 20mm

Section : MC 1.2

Accuracy Class : 1.0

Product Code	Ratio	Burden	Class	ID
TERMINAL TYPE				
MNB 26-5B-20-(4T)	25/1A	5	1.0	20
MNB 31-5B-20-(4T)	30/1A	5	1.0	20
MNB 41-5B-20-2T	40/1A	5	1.0	20
MNB 51-5B-20-2T	50/1A	5	1.0	20
MNB 61-5B-20-2T	60/1A	5	1.0	20
MNB 81-5B-20	80/1A	5	1.0	20
MNB 101-5B-20	100/1A	5	1.0	20
MNB 126-5B-20	125/1A	5	1.0	20
MNB 151-5B-20	150/1A	5	1.0	20

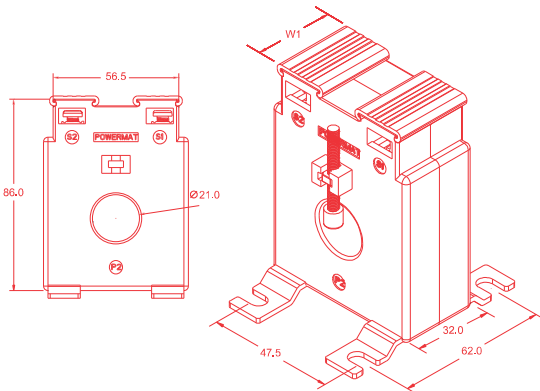

Moulded Case Metering Current Transformers Secondary : 5A, ID : 33/16mm

Section : MC 2.1

Accuracy Class : 1.0

Product Code	Ratio	Burden	Class	ID
TERMINAL TYPE				
MNB 155-2.5B-33/16	150/5A	2.5	1.0	33/16
MNB 205-2.5B-33/16	200/5A	2.5	1.0	33/16
MNB 255-5B-33/16	250/5A	5	1.0	33/16
MNB 305-5B-33/16	300/5A	5	1.0	33/16

Moulded Case Metering Current Transformers Secondary : 1A, ID : 33/16mm

Section : MC 2.2

Accuracy Class : 1.0

Product Code	Ratio	Burden	Class	ID
TERMINAL TYPE				
MNB 151-2.5B-33/16	150/1A	2.5	1.0	33/16
MNB 201-2.5B-33/16	200/1A	2.5	1.0	33/16
MNB 251-5B-33/16	250/1A	5	1.0	33/16
MNB 301-5B-33/16	300/1A	5	1.0	33/16

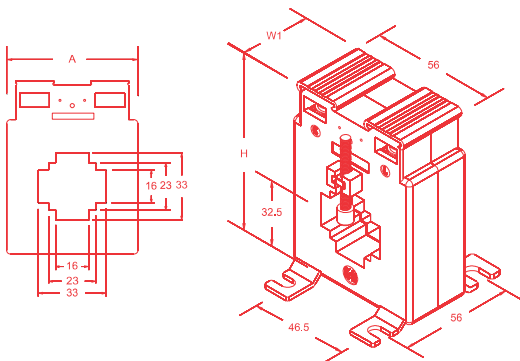

**Moulded Case Metering Current Transformers
Secondary : 5A, ID : 40/13mm**

Section : MC 3.1 Accuracy Class : 1.0

Product Code	Ratio	Burden	Class	ID
MNB 255 -5B-40/13	250/5A	5	1.0	40/13
MNB 305 -5B-40/13	300/5A	5	1.0	40/13
MNB 405 -5B-40/13	400/5A	5	1.0	40/13
MNB 505 -5B-40/13	500/5A	5	1.0	40/13

TERMINAL TYPE



**Moulded Case Metering Current Transformers
Secondary : 1A, ID : 40/13mm**

Section : MC 3.2 Accuracy Class : 1.0

Product Code	Ratio	Burden	Class	ID
MNB 251 -5B-40/13	250/1A	5	1.0	40/13
MNB 301 -5B-40/13	300/1A	5	1.0	40/13
MNB 405 -5B-40/13	400/1A	5	1.0	40/13
MNB 501 -5B-40/13	500/1A	5	1.0	40/13

TERMINAL TYPE

**Moulded Case Metering Current Transformers
Secondary : 5A, ID : 50/13mm**

Section : MC 4.1 Accuracy Class : 1.0

Product Code	Ratio	Burden	Class	ID
MNB 405 -10B-50/13	400/5A	10	1.0	50/13
MNB 505 -10B-50/13	500/5A	10	1.0	50/13
MNB 605 -10B-50/13	600/5A	10	1.0	50/13
MNB 805 -10B-50/13	800/5A	10	1.0	50/13

TERMINAL TYPE

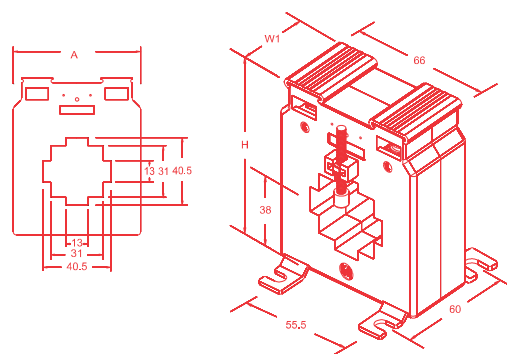

**Moulded Case Metering Current Transformers
Secondary : 1A, ID : 50/13mm**

Section : MC 4.2 Accuracy Class : 1.0

Product Code	Ratio	Burden	Class	ID
MNB 401 -10B-50/13	400/1A	10	1.0	50/13
MNB 501 -10B-50/13	500/1A	10	1.0	50/13
MNB 601 -10B-50/13	600/1A	10	1.0	50/13
MNB 801 -10B-50/13	800/1A	10	1.0	50/13

TERMINAL TYPE

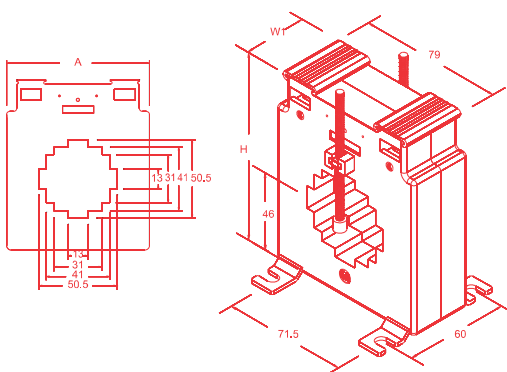

**Moulded Case Metering Current Transformers
Secondary : 5A, ID : 83/16mm**

Section : MC 5.1 Accuracy Class : 1.0

Product Code	Ratio	Burden	Class	ID
MNB 805 -15B-83/16	800/5A	15	1.0	83/16
MNB 1005 -15B-83/16	1000/5A	15	1.0	83/16
MNB 1205 -15B-83/16	1200/5A	15	1.0	83/16
MNB 1605 -15B-83/16	1600/5A	15	1.0	83/16
MNB 2005 -15B-83/16	2000/5A	15	1.0	83/16

TERMINAL TYPE

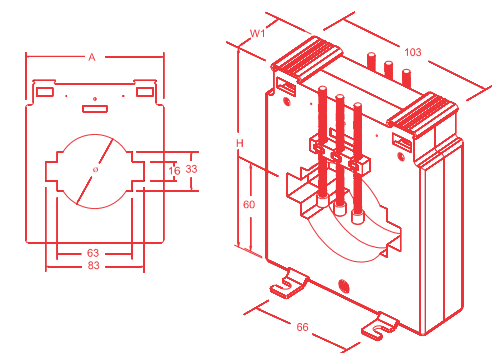

**Moulded Case Metering Current Transformers
Secondary : 1A, ID : 83/16mm**

Section : MC 5.2 Accuracy Class : 1.0

Product Code	Ratio	Burden	Class	ID
MNB 805 -15B-83/16	800/1A	15	1.0	83/16
MNB 1005 -15B-83/16	1000/1A	15	1.0	83/16
MNB 1205 -15B-83/16	1200/1A	15	1.0	83/16
MNB 1605 -15B-83/16	1600/1A	15	1.0	83/16
MNB 2005 -15B-83/16	2000/1A	15	1.0	83/16

TERMINAL TYPE

All Dimensions are in MM • Above Current Transformers are CE certified.

Current Transformers



Special Class Protection Current Transformers Secondary : 5A, ID : 105/35mm

RESIN CAST TERMINAL TYPE

Section : SP 1.1

Accuracy Class : PS

Product Code	Ratio	VK	Class	ID
RSC 805 -30V-105/35	800/5A	30	PS	105/35
RSC 1005 -35V-105/35	1000/5A	35	PS	105/35
RSC 1205 -35V-105/35	1200/5A	35	PS	105/35
RSC 1255 -40V-105/35	1250/5A	40	PS	105/35
RSC 1605 -45V-105/35	1600/5A	45	PS	105/35

Special Class Protection Current Transformers Secondary : 1A, ID : 105/35mm

RESIN CAST TERMINAL TYPE

Section : SP 1.2

Accuracy Class : PS

Product Code	Ratio	VK	Class	ID
RSC 801 -115V-105/35	800/1A	115	PS	105/35
RSC 1001 -140V-105/35	1000/1A	140	PS	105/35
RSC 1201 -170V-105/35	1200/1A	170	PS	105/35
RSC 1251 -180V-105/35	1250/1A	180	PS	105/35
RSC 1601 -220V-105/35	1600/1A	220	PS	105/35

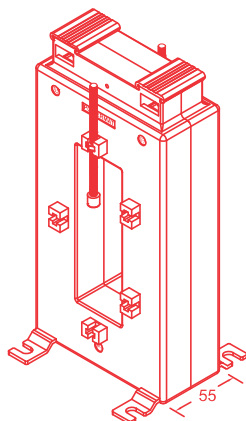
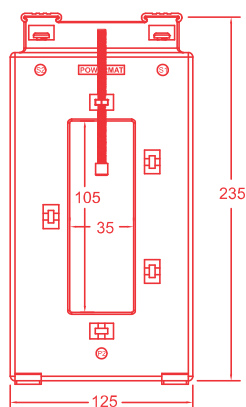

Special Class Protection Current Transformers Secondary : 5A, ID : 155/50mm

RESIN CAST TERMINAL TYPE

Section : SP 2.1

Accuracy Class : PS

Product Code	Ratio	VK	Class	ID
RSC 1605 -40V-155/50	1600/5A	40	PS	155/50
RSC 2005 -50V-155/50	2000/5A	50	PS	155/50
RSC 2505 -60V-155/50	800/5A	60	PS	155/50
RSC 3005 -70V-155/50	800/5A	70	PS	155/50
RSC 3205 -75V-155/50	800/5A	75	PS	155/50

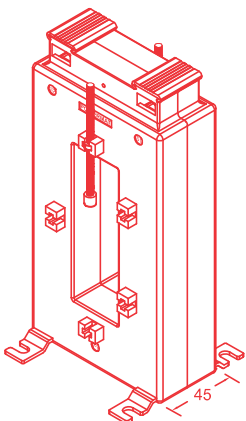
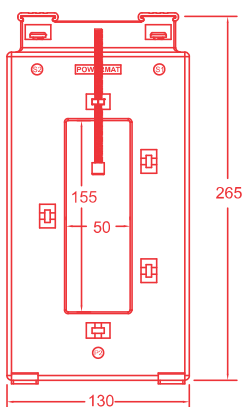

Special Class Protection Current Transformers Secondary : 1A, ID : 155/50mm

RESIN CAST TERMINAL TYPE

Section : SP 2.2

Accuracy Class : PS

Product Code	Ratio	VK	Class	ID
RSC 1601 -130V-155/50	1600/1A	130	PS	155/50
RSC 2001 -150V-155/50	2000/1A	150	PS	155/50
RSC 2501 -200V-155/50	2500/1A	200	PS	155/50
RSC 3001 -230V-155/50	3000/1A	230	PS	155/50
RSC 3201 -250V-155/50	3200/1A	250	PS	155/50

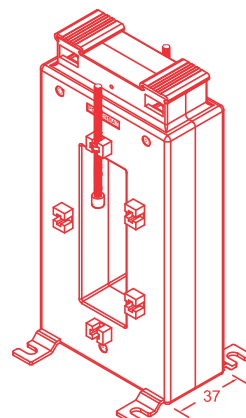
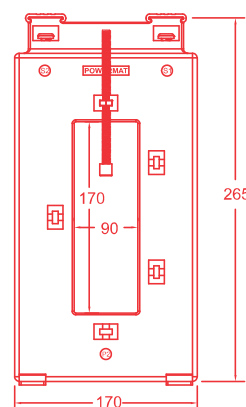

Special Class Protection Current Transformers Secondary : 5A, ID : 170/90mm

RESIN CAST TERMINAL TYPE

Section : SP 3.1

Accuracy Class : PS

Product Code	Ratio	VK	Class	ID
RSC 2505 -40V-170/90	2500/5A	40	PS	170/90
RSC 3005 -50V-170/90	3000/5A	50	PS	170/90
RSC 3205 -60V-170/90	3200/5A	60	PS	170/90
RSC 4005 -70V-170/90	4000/5A	70	PS	170/90
RSC 5005 -75V-170/90	5000/5A	75	PS	170/90

Special Class Protection Current Transformers Secondary : 1A, ID : 170/90mm

RESIN CAST TERMINAL TYPE

Section : SP 3.2

Accuracy Class : PS

Product Code	Ratio	VK	Class	ID
RSC 2501 -200V-170/90	2500/1A	200	PS	170/90
RSC 3001 -230V-170/90	3000/1A	230	PS	170/90
RSC 3201 -250V-170/90	3200/1A	250	PS	170/90
RSC 4001 -260V-170/90	4000/1A	260	PS	170/90
RSC 5001 -270V-170/90	5000/1A	270	PS	170/90

All Dimensions are in MM • Above Current Transformers are CE certified.

Busbar Insulators & Supports

An **electrical insulator** is a material whose internal electric charges do not flow freely, and therefore very hard to conduct an electric current under the influence of an electric field. A perfect insulator does not exist, but some materials such as glass, paper and Teflon, which have high resistivity, are very good electrical insulators. Insulators are used in electrical equipment to support and separate electrical conductors without allowing current through themselves.

Electric insulation is a vital part of an electrical power system. Although the cost of insulation is only a small fraction of the apparatus or line cost, line performance is highly dependent on insulation integrity. Insulation failure may cause permanent equipment damage and long-term outages. The potential financial losses emphasize the importance of a reliable design of the insulation.

The capacities of modern-day electrical plant and machinery are such that the power handled by their control systems gives rise to very large forces. Bus bars, like all the other equipment in the system, have to be able to withstand these forces without damage. It is essential that the materials used in their construction should have the best possible mechanical properties and are designed to operate within the temperature limits laid down in BS 159, BS EN 60439-1:1994, or other national or international standards.

Busbar Insulator or support plays a vital role in the panel therefore one should be very careful while selecting the busbar insulator or support for their application. We use three type of material.

1. Sheet Molding Compound
2. Dough Molding Compound
3. Polyamide 6,6

1. Sheet Molding Compound (SMC)

Sheet Molding Compound (Halogen Free) is a polymeric composite material made of the mixture of Unsaturated Polymer Resin, Processing Additives, Cross Linked Catalyst, Shrink Control Polyester, Mould Release Agent, Fire Retardant Agent, Color Pigments, Inorganic Fillers, Glass Sheet (20% to 25%) & Other Additives. POWERMAT SMC (Halogen Free as per IEC : 61249-2-21) is certified by UL India, CE & Compliance with RoHS Norms. SMC is used for Bus bar Supports only. Flammability Index is V-0.

2. Dough Molding Compound (DMC)

Dough Molding Compound is a polymeric composite material made of the mixture of Unsaturated Polymer Resin, Processing Additives, Cross Linked Catalyst, Shrink Control Polyester, Mould Release Agent, Fire Retardant Agent, Color Pigments, Inorganic Fillers, Glass Chops (15% to 20%) & Other Additives. POWERMAT DMC (Halogen Free as per IEC : 61249-2-21) is certified by UL India, CE & Compliance with RoHS Norms. DMC can be used for Bus bar Insulators as well as for making Bus bar Supports. Flammability Index is V-0.

3. Polyamide 6,6

Polyamide 6,6 is a 17% glass fiber reinforced polyamide 66 resin. It is stronger material (Mechanically & Electrically) as compared to Sheet Molding Compound & Dough Molding Compound. Flammability Index of this material is HB as per UL 94. It has high wear & abrasive resistance, good insulating properties, resistance to alkalies & other organic chemicals.

Please see page no. 36 for Technical specification of DMC/SMC & Polyamide 6, 6

Technical Specification

PROPERTIES	UNITS	TEST METHODS	VALUES		
			SMC	DMC	POLYAMIDE
Physical					
Specific Gravity	-	ASTM D-792	1.7	1.9	1.39
Glass Contents	%	N/A	25	15	33
Water Absorption (24 Hrs)	%	ASTM D-570	0.2	0.15	1.2
Mechanical					
Tensile Strength	(Kgf/cm ²)	ASTM D-638	700	400	1200-1300
Flexural Strength	(Kgf/cm ²)	ASTM D-790	1550	900	2500-2800
Impact Strength Izod	(J/m)	ASTM D-265	600	250	117
Compressive Strength	(Kgf/cm ²)	ASTM D-695	1800	1500	NA
Electrical					
Dielectric Strength	(KV/mm)	ASTM D-149	12	10	20
Comparative Tracking Index	(Volts)	BS-5901	>600	>600	>600
ARC Resistance	(Secs.)	ASTM D-495	180	180	200
Flammability Index	-	UL-94	V-0	V-0	HB / V0
Glow Wire Ignition Test Over 3mm Thickness Specimen	(°C)	IEC-60695-2-13	960	960	746 / 930
Hot Wire Ignition Test	(Secs.)	ASTM D-3874	>120	>120	7-15
RTI, Str (Thickness 3mm)	(°C)	UL-746B	130	130	130
RTI, Elect. (Thickness 3mm)	(°C)	UL-746B	105	105	130
High Voltage Arc Tracking Rate	(mm/min)	UL-746A	0 through 10	0 through 10	over 10 through 25.4
High Amp Arc Ignition	(mean no. or arcs)	UL-746A	>120	>120	>120
Material Group	-	IEC-60112	1	1	1
Pollution Degree	-	IEC-60950	3	3	3
Insulation Class	-	JIS C 4003	B	B	B
Working Temp	(°C)	-	(-) 40°C to 135°C	(-) 40°C to 135°C	(-) 40°C to 135°C

TOLERANCE CHART	
DIM (mm)	TOLERANCE (±)
1-15	0.25 mm
16-50	0.5 mm
51-100	1.0 mm
101- 250	1.5 mm
250 & above	2 mm

THE ABOVE VALUES ARE FOR THE STANDARD FORMULATION FOLLOWED BY THE COMPANY. WE HAVE FACILITIES FOR MANUFACTURING SMC, DMC & POLYAMIDE ACCORDING TO THE CUSTOMER REQUIREMENTS.
(SMC = SHEET MOULDING COMPOUND)
(DMC = DOUGH MOULDING COMPOUND)

IMPORTANT NOTE

FOR TECHNICAL NOTES OF DMC, SMC, BUS BAR SUPPORTS, SHORT CIRCUIT AND FAULT LEVEL CALCULATIONS PLEASE ASK FOR OUR LATEST TECHNICAL NOTES 01/15.

ALL DATA GIVEN IN THIS CATALOGUE HAS BEEN DETERMINED CAREFULLY AT THE COMPANY'S TEST LAB. WITH THE VARIETY OF PURPOSE FOR WHICH THE PRODUCTS ARE USED, AND THE METHODS AND APPLICATION TECHNIQUES EMPLOYED, HOWEVER THE DATA AND INFORMATION ARE GIVEN ONLY AS A GUIDE, AND ARE NOT BINDING. NO GUARANTEE OF THERE AUTHENTICITY CAN THEREFORE BE ASSUMED IN ALL SITUATIONS THE COMPANY RESERVES THE RIGHT TO MODIFY FEATURES WITHOUT PRIOR NOTICE IN VIEW OF CONTINUED IMPROVEMENTS AND DEVELOPMENTS.



Standoff Insulators (Polyamide-Supports)

POWERMAT Code	Dimension				Nominal Voltage (AC / DC)	Std. Pkg. (Nos.)	Box Wt. (Kg.)
	H mm	AF mm	Ø R mm	TL mm			
PH 415 (M4)-XX	15	15	12	3.5	800/1100	300	1.800
PH 420 (M4)-XX	20	18	15	5	1100/1500	300	3.000
PH 620 (M6)-XX	20	18	16	5	1100/1500	300	4.800
PH 6(7)20 (M6)-XX	20	18	16	7	1100/1500	300	4.800
PH 525 (M5)-XX	25	20	16	7	1400/1900	200	4.200
PH 625 (M6)-XX	25	20	16	7	1400/1900	200	4.000
PH 630 (M6)-XX	30	30	26	9	1600/2200	50	2.300
PH 830 (M8)-XX	30	30	26	9	1600/2200	50	2.150
PH 635 (M6)-XX	35	40	34	12	1900/2600	50	4.400
PH 835 (M8)-XX	35	40	34	12	1900/2600	50	4.150
PH 1035 (M10)-XX	35	40	34	12	1900/2600	50	3.950
PH 840S (M8)-XX	40	41	34	12	2200/3000	50	5.900
PH 640 (M6)-XX	40	45	40	12	2200/3000	50	5.900
PH 840 (M8)-XX	40	45	40	12	2200/3000	50	5.750
PH 1040 (M10)-XX	40	45	40	12	2200/3000	50	5.500
PH 1240M (M12)-XX	40	45	40	12	2200/3000	50	5.550
PH 645L (M6)-XX	45	41	34	12	2500/3500	40	5.300
PH 845L (M8)-XX	45	41	34	12	2500/3500	40	5.250
PH 845 (M8)-XX	45	50	40	12	2500/3500	40	5.280
PH 1045 (M10)-XX	45	50	40	12	2500/3500	40	5.120
PH 650 (M6)-XX	50	50	40	12	2800/3900	40	6.040
PH 850 (M8)-XX	50	50	40	17	2800/3900	40	6.160
PH 1050 (M10)-XX	50	50	40	17	2800/3900	40	5.880
PH 1250 (M12)-XX	50	50	40	17	2800/3900	40	5.800
PH 860 (M8)-XX	60	54	45	17	3300/4600	20	4.180
PH 1060 (M10)-XX	60	54	45	17	3300/4600	20	4.800
PH 1260 (M12)-XX	60	54	45	17	3300/4600	20	4.620
PH 1660 (M16)-XX	60	54	45	17	3300/4600	20	4.260
PH 1070 (M10)-XX	70	65	50	21	3900/5400	10	3.550
PH 1270 (M12)-XX	70	65	50	21	3900/5400	10	3.510
PH 1670 (M16)-XX	70	65	50	21	3900/5400	10	3.400
PH 1075 (M10)-XX	75	65	50	21	4200/5800	10	3.220
PH 1275 (M12)-XX	75	65	50	21	4200/5800	10	3.660
PH 1675 (M16)-XX	75	65	50	21	4200/5800	10	3.570
PH 1280 (M12)-XX	80	65	50	25	4500/6300	10	3.990
PH 1680 (M16)-XX	80	65	50	25	4500/6300	10	3.600
PH 12100 (M12)-XX	100	65	50	25	5600/7800	12	6.000
PH 16100 (M16)-XX	100	65	50	25	5600/7800	12	5.520

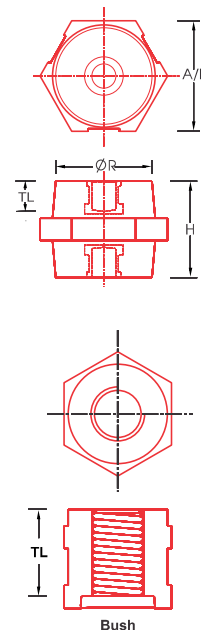

UL File No. QEUY2.E249670 (Halogen Free)

Material :

HB Grade : Polyamide / Nylon 6/6 (17% Glass Filled, Natural Col.)

V0 Grade : Polyamide / Nylon 6/6 (25% Glass Filled, Black)

All Dimensions are in MM

TL : Effective Thread Length

All Insulators are CE certified

Insert : Aluminium / Brass / Steel (Zinc Passivated) / Stainless Steel

Mounting Detail of PH and PAGP Series on Page No. 80, 81

Insert Material detail on page no. 83

* For maximum torque please see page no. 83

For technical details of Busbar support & Insulator, please refer POWERMAT TECHNICAL NOTES - 02/18

For checking the suitability of a support & insulator for a fault current, please ask for POWERMAT FAULT LEVEL CALCULATOR Software.

Plastic Spacer

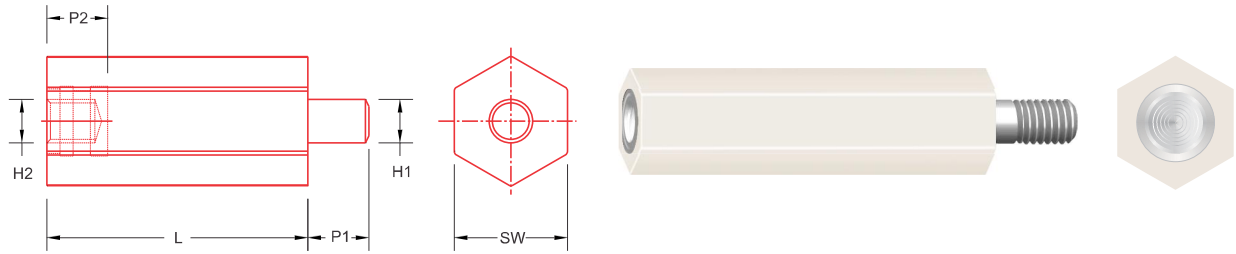

PLASTIC SPACER

Product Code	Length (L) mm	Stud (H1 X P1) mm	Insert (H2 X P2) mm	AF (SW) mm	Std. Pkg. (Nos.)	Box Wt. (Kg.)
3S15-07	15	M3 x 7mm	M3 x 7mm	7	1000	1.000
3S20-07	20	M3 x 7mm	M3 x 7mm	7	1000	1.010
3S25-07	25	M3 x 7mm	M3 x 7mm	7	500	1.000
3S30-07	30	M3 x 7mm	M3 x 7mm	7	500	1.200
3S40-07	40	M3 x 7mm	M3 x 7mm	7	250	0.700
3S55-07	55	M3 x 7mm	M3 x 7mm	7	250	0.850
4S15-09	15	M4 x 7mm	M4 x 7mm	9	500	0.650
4S20-09	20	M4 x 7mm	M4 x 7mm	9	500	0.720
4S25-09	25	M4 x 7mm	M4 x 7mm	9	400	0.800
4S30-09	30	M4 x 7mm	M4 x 7mm	9	250	0.750
4S40-09	40	M4 x 7mm	M4 x 7mm	9	200	0.700
4S55-09	55	M4 x 7mm	M4 x 7mm	9	200	0.860
4S60-09	60	M4 x 7mm	M4 x 7mm	9	200	0.950
4S90-09	90	M4 x 7mm	M4 x 7mm	9	100	0.900
5S15-13	15	M5 x 7mm	M5 x 7mm	13	500	0.750
5S30-13	30	M5 x 7mm	M5 x 7mm	13	250	0.725
5S45-13	45	M5 x 7mm	M5 x 7mm	13	250	1.000
5S55-13	55	M5 x 7mm	M5 x 7mm	13	250	1.350
5S70-13	70	M5 x 7mm	M5 x 7mm	13	100	0.700
5S85-13	85	M5 x 7mm	M5 x 7mm	13	100	0.850
5S120-13	120	M5 x 7mm	M5 x 7mm	13	50	0.600
6S15-13	15	M6 x 7mm	M6 x 7mm	13	500	0.750
6S20-13	20	M6 x 7mm	M6 x 7mm	13	250	0.600
6S25-13	25	M6 x 7mm	M6 x 7mm	13	250	0.750
6S30-13	30	M6 x 7mm	M6 x 7mm	13	200	0.700
6S45-13	45	M6 x 7mm	M6 x 7mm	13	200	1.100
6S60-13	60	M6 x 7mm	M6 x 7mm	13	100	0.720
6S70-13	70	M6 x 7mm	M6 x 7mm	13	100	0.840
6S120-13	120	M6 x 7mm	M6 x 7mm	13	50	0.700

- Material : PBT
- All Dimensions are in MM
- TL : Effective Thread Length
- All Insulators are CE certified

- Insert : Aluminium / Brass / Steel (Zinc Passivated) / Stainless Steel
- Insert Material detail on page no. 83
- For maximum torque please see page no. 83

- For technical details of Busbar support & Insulator, please refer POWERMAT TECHNICAL NOTES - 02/18.
- For checking the suitability of a support & insulator for a fault current, please ask for POWERMAT FAULT LEVEL CALCULATOR Software.

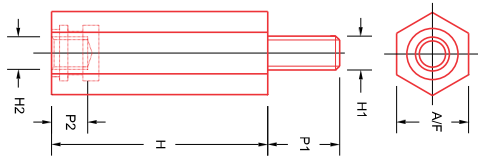

DMC SPACER

HEX Face to Face (AF 7mm)

Part Code	Height (H) (mm)	A/F (mm)	Stud P1 (H1 x P1)	Stud P2 (H2 x P2)	Std. Pkg. (Nos.)	Box Wt. (Kg.)
07HH315-M3.07F3.07	15	7	M3 x 7mm	M3 x 7mm (TL-5)	1000	3.000
07HH320-M3.07F3.07	20	7	M3 x 7mm	M3 x 7mm (TL-5)	500	2.250
07HH325-M3.07F3.07	25	7	M3 x 7mm	M3 x 7mm (TL-5)	500	2.500
07HH330-M3.07F3.07	30	7	M3 x 7mm	M3 x 7mm (TL-5)	250	1.250
07HH335-M3.07F3.07	35	7	M3 x 7mm	M3 x 7mm (TL-5)	250	1.500
07HH340-M3.07F3.07	40	7	M3 x 7mm	M3 x 7mm (TL-5)	200	2.000
07HH350-M3.07F3.07	50	7	M3 x 7mm	M3 x 7mm (TL-5)	100	2.500

HEX Face to Face (AF 10mm)

10HH415-M4.07F4.07	15	10	M4 x 7mm	M4 x 7mm (TL-5)	1000	3.500
10HH420-M4.07F4.07	20	10	M4 x 7mm	M4 x 7mm (TL-5)	500	2.750
10HH425-M4.07F4.07	25	10	M4 x 7mm	M4 x 7mm (TL-5)	500	3.000
10HH430-M4.07F4.07	30	10	M4 x 7mm	M4 x 7mm (TL-5)	250	1.450
10HH435-M4.07F4.07	35	10	M4 x 7mm	M4 x 7mm (TL-5)	250	1.800
10HH440-M4.07F4.07	40	10	M4 x 7mm	M4 x 7mm (TL-5)	200	2.250
10HH450-M4.07F4.07	50	10	M4 x 7mm	M4 x 7mm (TL-5)	200	2.500
10HH460-M4.07F4.07	60	10	M4 x 7mm	M4 x 7mm (TL-5)	100	2.800
10HH470-M4.07F4.07	70	10	M4 x 7mm	M4 x 7mm (TL-5)	50	2.100
10HH480-M4.07F4.07	80	10	M4 x 7mm	M4 x 7mm (TL-5)	50	2.350
10HH490-M4.07F4.07	90	10	M4 x 7mm	M4 x 7mm (TL-5)	50	2.850

HEX Face to Face (AF 14mm)

14HH515-M5.07F5.07	15	14	M5 x 7mm	M5 x 7mm (TL-5)	200	1.300
14HH520-M5.07F5.07	20	14	M5 x 7mm	M5 x 7mm (TL-5)	200	2.200
14HH525-M5.07F5.07	25	14	M5 x 7mm	M5 x 7mm (TL-5)	200	2.500
14HH530-M5.07F5.07	30	14	M5 x 7mm	M5 x 7mm (TL-5)	200	3.000
14HH535-M5.07F5.07	35	14	M5 x 7mm	M5 x 7mm (TL-5)	200	3.250
14HH540-M5.07F5.07	40	14	M5 x 7mm	M5 x 7mm (TL-5)	200	3.500
14HH545-M5.07F5.07	45	14	M5 x 7mm	M5 x 7mm (TL-5)	100	3.000
14HH550-M5.07F5.07	50	14	M5 x 7mm	M5 x 7mm (TL-5)	100	4.500
14HH560-M5.07F5.07	60	14	M5 x 7mm	M5 x 7mm (TL-5)	100	4.800
14HH570-M5.07F5.07	70	14	M5 x 7mm	M5 x 7mm (TL-5)	50	3.000
14HH580-M5.07F5.07	80	14	M5 x 7mm	M5 x 7mm (TL-5)	50	3.500
14HH590-M5.07F5.07	90	14	M5 x 7mm	M5 x 7mm (TL-5)	50	4.250
14HH5100-M5.07F5.07	100	14	M5 x 7mm	M5 x 7mm (TL-5)	25	2.250
14HH5120-M5.07F5.07	120	14	M5 x 7mm	M5 x 7mm (TL-5)	25	2.500
14HH615-M6.07F6.07	15	14	M6 x 7mm	M6 x 7mm (TL-5)	200	1.300
14HH620-M6.07F6.07	20	14	M6 x 7mm	M6 x 7mm (TL-5)	200	2.200
14HH625-M6.07F6.07	25	14	M6 x 7mm	M6 x 7mm (TL-5)	200	2.500
14HH630-M6.07F6.07	30	14	M6 x 7mm	M6 x 7mm (TL-5)	200	3.000
14HH635-M6.07F6.07	35	14	M6 x 7mm	M6 x 7mm (TL-5)	200	3.250
14HH640-M6.07F6.07	40	14	M6 x 7mm	M6 x 7mm (TL-5)	100	3.500
14HH645-M6.07F6.07	45	14	M6 x 7mm	M6 x 7mm (TL-5)	100	3.000
14HH650-M6.07F6.07	50	14	M6 x 7mm	M6 x 7mm (TL-5)	100	4.500
14HH660-M6.07F6.07	60	14	M6 x 7mm	M6 x 7mm (TL-5)	100	4.800
14HH670-M6.07F6.07	70	14	M6 x 7mm	M6 x 7mm (TL-5)	50	3.000
14HH680-M6.07F6.07	80	14	M6 x 7mm	M6 x 7mm (TL-5)	50	3.500
14HH690-M6.07F6.07	90	14	M6 x 7mm	M6 x 7mm (TL-5)	50	4.250
14HH6100-M6.07F6.07	100	14	M6 x 7mm	M6 x 7mm (TL-5)	25	2.250
14HH6120-M6.07F6.07	120	14	M6 x 7mm	M6 x 7mm (TL-5)	25	2.500

• Material : DMC (Dough Moulding Compound) UL File No. QEU2.E249670 (Halogen Free)

• All Dimensions are in MM

• TL : Effective Thread Length

• All Insulators are certified

• For technical details of Busbar support & Insulator, please refer POWERMAT TECHNICAL NOTES - 02/18.

• For checking the suitability of a support & insulator for a fault current, please ask for POWERMAT FAULT LEVEL CALCULATOR Software.

• Insert : Aluminium / Brass / Steel (Zinc Passivated) / Stainless Steel

• Insert Material detail on page no. 83

• For maximum torque please see page no. 83

Standoff Insulator

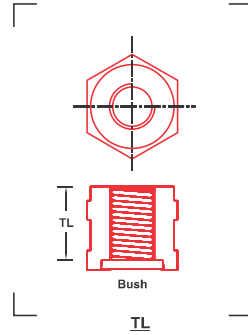
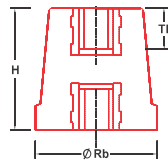

Conical

Part No. (Insert)	Height (H) mm	Dimension			Nominal Voltage (AC / DC)	Std. Pkg. (Nos.)	Box Wt. (Kg.)
		Rt Ø mm	Rb Ø mm	TL mm			
C 520 (M5)	20	16	20	5	800/1100	200	2.800
C 620 (M6)	20	16	20	5	800/1100	200	3.000
C 625 (M6)	25	19	25	7	1000/1400	200	5.000
C 630 (M6)	30	25	30	9	1200/1600	50	2.050
C 830 (M8)	30	25	30	9	1200/1600	50	2.150
C 635 (M6)	35	28	35	12	1400/1900	50	3.500
C 835 (M8)	35	28	35	12	1400/1900	50	3.700
C 640 (M6)	40	33	40	12	1600/2200	50	4.400
C 840 (M8)	40	33	40	12	1600/2200	50	4.800
C 1040 (M10)	40	33	40	12	1600/2200	50	5.200
C 645 (M6)	45	36	45	12	1800/2500	25	2.900
C 845 (M8)	45	36	45	12	1800/2500	25	3.200
C 850 (M8)	50	40	50	17	2000/2800	25	4.000
C 1050 (M10)	50	40	50	17	2000/2800	25	4.000
C 1250 (M12)	50	40	50	17	2000/2800	25	4.200
C 1060 (M10)	60	40	50	17	2400/3300	25	4.800
C 1260 (M12)	60	40	50	17	2400/3300	25	5.000
C 1070 (M10)	70	41	50	22	2800/3900	25	5.800
C 1270 (M12)	70	41	50	22	2800/3900	25	6.000

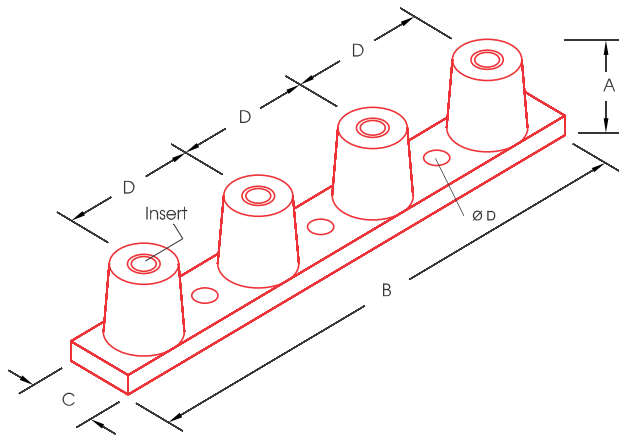

POWERMAT code	Dimension							Std. Pkg. (Nos.)	Box Wt. (Kg.)
	A	B	C	E	ØD	Insert	TL		
4C-525	25	120	20	35	6	M 5	7	50	3.500
4C-630	30	185	25	52	6.5	M 6	9	25	2.880
4C-845	45	260	35	70	8	M 8	12	10	3.400
PD4C-628	28	215	25	60	6.2	M 6	7	25	3.800
PD4C-845	45	230	35	60	8	M 8	12	10	4.200

- Material : DMC (Dough Moulding Compound) UL File No. QEUY2.E249670 (Halogen Free)
- Product : UL Certification File No. QEUY2.E314972
- All Dimensions are in MM
- TL : Effective Thread Length
- All Insulators are certified

- Insert : Aluminium / Brass / Steel (Zinc Passivated) / Stainless Steel
- Mounting Detail on Page No. 80
- Insert Material detail on page no. 83
- For maximum torque please see page no. 83

- For technical details of Busbar support & Insulator, please refer POWERMAT TECHNICAL NOTES - 02/18.
- For checking the suitability of a support & insulator for a fault current, please ask for POWERMAT FAULT LEVEL CALCULATOR Software.

Hexagonal

Part No. (Insert)	Height (H) mm	Dimension			Nominal Voltage (AC / DC)	Std. Pkg. (Nos.)	Box Wt. (Kg.)
		AF mm	Ø R mm	TL mm			
H 312 (M3)	12	8	7	3	500/700	500	1.500
H 416 (M4)	16	14	11	3.5	640/800	400	2.000
H 516 (M5)	16	14	11	3.5	640/800	400	2.000
H 420 (M4)	20	18	14	5	800/1100	200	2.000
H 520 (M5)	20	18	14	5	800/1100	200	2.000
H 620 (M6)	20	18	14	5	800/1100	200	2.200
H 425 (M4)	25	21	16	7	1000/1400	200	4.450
H 525 (M5)	25	21	16	7	1000/1400	200	4.500
H 62125 (M6)	25	21	16	7	1000/1400	100	3.500
H 625 (M6)	25	25	22	7	1000/1400	200	4.500
MH 625 (M6)	25	19	17	7	1000/1400	200	4.200
H 825 (M8)	25	33	25	7	1000/1400	50	2.600
H 630 (M6)	30	32	24	9	1200/1600	50	2.500
H 830 (M6)	30	32	25	9	1200/1600	50	2.800
H 1030 (M10)	30	32	25	9	1200/1600	50	3.100
H 635 (M6)	35	32	26	12	1400/1900	50	3.500
H 835 (M8)	35	32	26	12	1400/1900	50	3.500
DLH 835 (M8)	35	35	26	12	1400/1900	50	3.800
MH 835 (M8)	35	40	33	12	1400/1900	50	4.700
H 1035 (M10)	35	32	26	12	1400/1900	50	3.600
MH 1035 (M10)	35	40	33	12	1400/1900	50	4.700
H 640 (M6)	40	38	30	12	1600/2200	50	4.600
H 840 (M8)	40	39	31	12	1600/2200	50	4.800
H 1040 (M10)	40	38	30	12	1600/2200	50	4.700
H 645 (M6)	45	40	32	12	1800/2500	25	3.200
H 845 (M8)	45	40	32	12	1800/2500	25	3.200
H 1045 (M10)	45	40	32	12	1800/2500	25	3.900
H 650 (M6)	50	46	35	12	2000/2800	25	3.800
H 850 (M8)	50	46	35	17	2000/2800	25	3.800
H 1050 (M10)	50	46	35	17	2000/2800	25	4.000
ENH 1050 (M10)	50	50	44	17	2000/2800	20	4.000
H 1250 (M12)	50	46	35	17	2000/2800	25	4.000
H 860 (M8)	60	50	38	17	2400/3300	25	4.800
H 1060 (M10)	60	50	38	17	2400/3300	25	5.000
H 1260 (M12)	60	50	38	17	2400/3300	25	4.846
ENH 1660 (M16)	60	60	55	22	2400/3300	20	5.800
H 865 (M8)	65	55	41	17	2600/3600	25	6.260
H 1065 (M10)	65	55	41	17	2600/3600	25	6.260
H 1265 (M12)	65	55	41	17	2600/3600	25	6.500
H 1070 (M10)	70	55	41	22	2800/3900	25	6.800
H 1270 (M12)	70	55	41	22	2800/3900	25	6.860
H 1670 (M16)	70	55	41	22	2800/3900	25	7.000
H 1075 (M10)	75	53	42	22	3000/4200	25	7.000
H 1275 (M12)	75	53	42	22	3000/4200	25	7.000
H 1076E (M10)	76	50	34	22	3000/4200	25	5.700
H 1276E (M12)	76	50	34	22	3000/4200	25	5.750

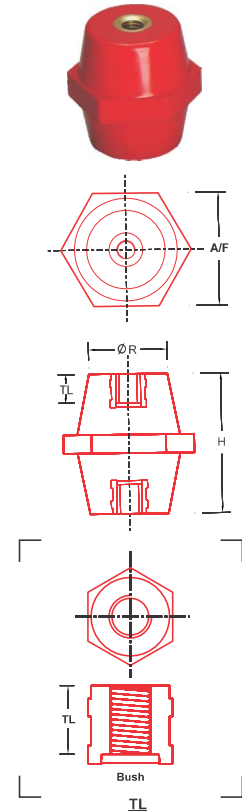

- Material : DMC (Dough Moulding Compound)  UL File No. QEUY2.E249670 (Halogen Free)
- Product : UL Certification File No. QEUY2.E314972
- All Dimensions are in MM
- TL : Effective Thread Length
- All Insulators are  certified

- Insert : Aluminium / Brass / Steel (Zinc Passivated) / Stainless Steel
- Mounting Detail on Page No. 80
- Insert Material detail on page no. 83
- For maximum torque please see page no. 83

- For technical details of Busbar support & Insulator, please refer POWERMAT TECHNICAL NOTES - 02/18.
- For checking the suitability of a support & insulator for a fault current, please ask for POWERMAT FAULT LEVEL CALCULATOR Software.

Standoff Insulator

Drum

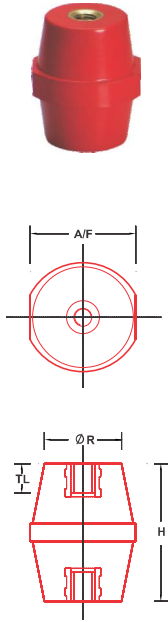

Part No. (Insert)	Height (H) mm	Dimension			Nominal Voltage (AC / DC)	Std. Pkg. (Nos.)	Box Wt. (Kg.)
		AF mm	Ø R mm	TL mm			
D 420 (M4)	20	18	14	5	800/1100	200	3.500
D 620 (M4)	20	18	14.5	5	800/1100	200	3.500
D 425 (M4)	25	21	16	7	1000/1400	200	4.200
D 625 (M6)	25	21	16	7	1000/1400	200	4.288
D 630 (M6)	30	33	25	9	1200/1600	50	2.600
D 830 (M8)	30	33	26	9	1200/1600	50	2.800
D 635 (M6)	35	32	26	9	1400/1900	50	2.676
D 835 (M8)	35	32	26	9	1400/1900	50	3.016
D 1035 (M10)	35	32	26	9	1400/1900	50	3.400
D 840 (M8)	40	39	30	12	1600/2200	50	4.400
D 1040 (M10)	40	39	31	12	1600/2200	50	4.500
D 845 (M8)	45	40	31	12	1800/2500	25	2.620
D 1045 (M10)	45	41	32	12	1800/2500	25	2.720
D 1245 (M12)	45	41	32	12	1800/2500	25	2.761
D 850 (M8)	50	48	36	17	2000/2800	25	3.600
D 1050 (M10)	50	48	35	17	2000/2800	25	3.664
D 1250 (M12)	50	48	35	17	2000/2800	25	3.828
D 851E (M8)	51	35	27	17	2040/2800	50	4.800
D 1051E (M10)	51	35	27	17	2040/2800	50	5.000
D 860 (M8)	60	52	38	17	2400/3300	25	4.500
D 1060 (M10)	60	52	37	17	2400/3300	25	4.570
D 1260 (M12)	60	52	37	17	2400/3300	25	4.600
D 865 (M8)	65	55	41	22	2600/3600	25	6.500
D 1065 (M10)	65	55	41	22	2600/3600	25	6.500
D 1265 (M12)	65	55	41	22	2600/3600	25	6.240
D 1070 (M10)	70	55	42	22	2800/3900	25	7.000
D 1270 (M12)	70	55	42	22	2800/3900	25	7.000
D 1075 (M10)	75	55	42	22	3000/4200	25	7.000
D 1275 (M12)	75	55	42	22	3000/4200	25	7.000
D 1276 (M12)	76	50	34	22	3000/4200	25	6.000

Cylindrical Series (Male - Male Combination)

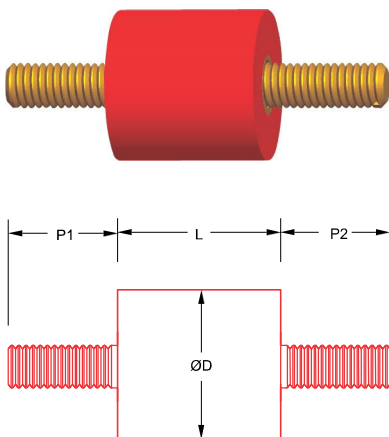

Part No.	Ø D mm	L mm	P1 mm	P2 mm	Nominal Voltage (AC / DC)
CY10.10-M3.05-M3.05	10	10	M3X5	M3X5	400/500
CY10.10-M3.05-M3.10	10	10	M3X5	M3X10	400/500
CY10.10-M3.08-M3.08	10	10	M3X8	M3X8	400/500
CY10.10-M3.10-M3.10	10	10	M3X10	M3X10	400/500
CY14.14-M3.10-M3.10	14	14	M3X10	M3X10	500/700
CY14.14-M4.10-M4.10	14	14	M4X10	M4X10	500/700
CY14.14-M5.10-M4.10	14	14	M5X10	M4X10	500/700
CY14.14-M5.10-M5.10	14	14	M5X10	M5X10	500/700
CY14.14-M6.10-M6.10	14	14	M6X10	M6X10	500/700
CY14.14-M6.10-M6.15	14	14	M6X10	M6X15	500/700
CY14.14-M6.15-M6.15	14	14	M6X15	M6X15	500/700
CY20.18-M6.07-M6.15	20	18	M6X7	M6X15	700/900
CY20.18-M6.15-M6.15	20	18	M6X15	M6X15	700/900
CY20.18-M6.15-M8.15	20	18	M6X15	M8X15	700/900
CY20.18-M8.08-M8.25	20	18	M8X8	M8X25	700/900
CY20.18-M8.20-M8.20	20	18	M8X20	M8X20	700/900

- Material : DMC (Dough Moulding Compound) UL File No. QEU2.E249670 (Halogen Free)
- Product : UL Certification File No. QEU2.E314972
- All Dimensions are in MM
- TL : Effective Thread Length
- All Insulators are certified

- Insert : Aluminium / Brass / Steel (Zinc Passivated) / Stainless Steel
- Mounting Detail on Page No. 80
- Insert Material detail on page no. 83
- For maximum torque please see page no. 83

- For technical details of Busbar support & Insulator, please refer POWERMAT TECHNICAL NOTES - 01/15.
- For checking the suitability of a support & insulator for a fault current, please ask for POWERMAT FAULT LEVEL CALCULATOR Software.

Cylindrical Series (Male - Female Combination)

Part No.	Ø D mm	L mm	P1 mm	P2 mm	Nominal Voltage (AC / DC)
CY14.17-M5.08-F5.07	14	17	M5X8	M5X7	600/800
CY14.17-M5.10-F5.07	14	17	M5X10	M5X7	600/800
CY14.17-M6.15-F6.07	14	17	M6X15	M6X7	600/800
CY14.26-M4.10-F4.07	14	26	M4X10	M4X7	1000/1400

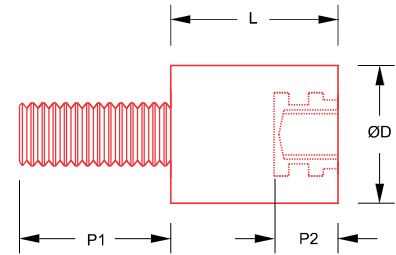

Cylindrical

Part No. (Insert)	Height (H) mm	Dimension Ø R mm	TL mm	Nominal Voltage (AC / DC)	Std. Pkg. (Nos.)	Box Wt. (Kg.)
CY 2223 (M8)	23	22	7	900/1200	200	5.600
CY 2225 (M6)	25	22	7	1000/1400	200	5.400
CY 2225 (M8)	25	22	7	1000/1400	200	5.800
CY 2630 (M8)	30	26	9	1200/1600	100	4.200
CY 2630 (M6)	30	26	9	1200/1600	100	4.500
CY 3030 (M6)	30	30	9	1200/1600	50	3.000
CY 3030 (M8)	30	30	9	1200/1600	50	3.200
CY 3030 (M10)	30	30	9	1200/1600	50	3.400
CY 4535 (M10)	35	45	9	1400/1900	25	4.500
CY 3036 (M8)	36	30	9	1500/2000	100	6.500
CY 2640 (M8)	40	26	12	1600/2200	100	6.200
CY 3040 (M6)	40	30	12	1600/2200	100	6.800
CY 3040 (M8)	40	30	12	1600/2200	100	6.900
CY 3040 (M10)	40	30	12	1600/2200	100	7.000
CY 4040 (M8)	40	40	12	1600/2200	50	6.000
CY 4540 (M10)	40	45	12	1600/2200	25	6.220
CY 4040 (M10)	40	40	12	1600/2200	50	6.400
CY 3045 (M10)	45	30	12	1600/2200	50	5.200
CY 2650 (M6)	50	26	12	2000/2800	50	3.800
CY 2650 (M8)	50	26	12	2000/2800	50	3.800
CY 3050 (M6)	50	30	12	2000/2800	50	4.800
CY 3050 (M8)	50	30	17	2000/2800	50	4.800
CY 3050 (M10)	50	30	17	2000/2800	50	4.800
CY 4050 (M8)	50	40	17	2000/2800	50	7.000
CY 4050 (M10)	50	40	17	2000/2800	50	7.000
CYD 4050 (M10)	50	40	17	2000/2800	50	7.000
CY 4550 (M10)	50	45	17	-	25	-
CY 5050 (M10)	50	50	17	2000/2800	25	5.800
CY 5050 (M12)	50	50	17	2000/2800	25	5.800
CY 3051 (M8)	51	30	17	2040/2800	50	4.800
CY 2660 (M6)	60	26	12	2400/3300	50	4.500
CY 2660 (M8)	60	26	17	2400/3300	50	4.500
CY 2660 (M10)	60	26	17	2400/3300	50	4.500
CY 3060 (M6)	60	30	12	2400/3300	50	5.200
CY 3060 (M8)	60	30	17	2400/3300	50	5.200
CY 3060 (M10)	60	30	17	2400/3300	50	5.200
CY 5060 (M10)	60	50	17	2400/3300	25	6.200
CY 5060 (M12)	60	50	17	2400/3300	25	6.200
CY 6060 (M10)	60	60	17	2400/3300	10	3.800
CY 6060 (M12)	60	60	17	2400/3300	10	3.800
CY 2663 (M6)	63	26	12	2500/3500	50	4.800
CY 2663 (M8)	63	26	17	2500/3500	50	4.800
CY 2663 (M10)	63	26	17	2500/3500	50	4.800
CY 3076 (M10)	76	30	22	3000/4200	50	5.800
CY 2690 (M6)	90	26	12	3600/5000	50	5.500

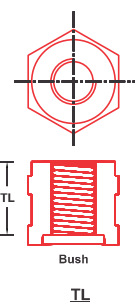
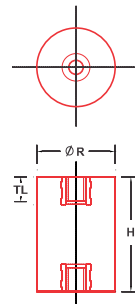
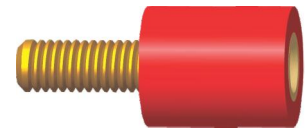

- Material : DMC (Dough Moulding Compound) eULus UL File No. QEUY2.E249670 (Halogen Free)
- Product : UL Certification File No. QEUY2.E314972
- All Dimensions are in MM
- TL : Effective Thread Length
- All Insulators are CE certified

- Insert : Aluminium / Brass / Steel (Zinc Passivated) / Stainless Steel
- Mounting Detail on Page No. 80
- Insert Material detail on page no. 83
- For maximum torque please see page no. 83

- For technical details of Busbar support & Insulator, please refer POWERMAT TECHNICAL NOTES - 01/15.
- For checking the suitability of a support & insulator for a fault current, please ask for POWERMAT FAULT LEVEL CALCULATOR Software.

Standoff Insulator

Full Hex

Part No. (Insert)	Height (H) mm	TL (mm)	Nominal Voltage (AC / DC)	Std. Pkg. (Nos.)	Box Wt. (Kg.)	Part No. (Insert)	Height (H) mm	TL (mm)	Nominal Voltage (AC / DC)	Std. Pkg. (Nos.)	Box Wt. (Kg.)
-------------------	---------------	---------	---------------------------	------------------	---------------	-------------------	---------------	---------	---------------------------	------------------	---------------

Hex Face to Face (A/F 14mm)

14HH 415 (M4)	15	3.5	600/800	400	2.654	14HH 515 (M5)	15	3.5	600/800	400	2.600
14HH 420 (M4)	20	5	800/1100	200	2.200	14HH 520 (M5)	20	5	800/1100	200	2.300
14HH 425 (M4)	25	7	1000/1400	200	2.500	14HH 525 (M5)	25	7	1000/1400	200	2.800
						14HH 527 (M5)	27	7	1000/1400	200	2.800

Hex Face to Face (A/F 20mm)

20HH 520 (M5)	20	5	800/1100	300	5.910	20HH 620 (M6)	20	5	800/1100	300	5.786
20HH 525 (M5)	25	7	1000/1400	200	3.869	20HH 625 (M6)	25	7	1000/1400	200	4.670
20HH 530 (M5)	30	7	1200/1600	200	5.600	20HH 630 (M6)	30	7	1200/1600	200	5.670
20HH 535 (M5)	35	9	1400/1900	200	6.800	20HH 635 (M6)	35	9	1400/1900	200	6.800
20HH 540 (M5)	40	12	1600/2200	200	7.620	20HH 640 (M6)	40	12	1600/2200	200	7.800
20HH 545 (M5)	45	12	1800/2500	100	4.100	20HH 645 (M6)	45	12	1800/2500	100	4.170
20HH 550 (M5)	50	12	2000/2800	100	4.500	20HH 650 (M6)	50	12	2000/2800	100	4.437
20HH 555 (M5)	55	12	2200/3000	100	4.700	20HH 655 (M6)	55	12	2200/3000	100	4.700
20HH 560 (M5)	60	12	2400/3300	100	5.200	20HH 660 (M6)	60	12	2400/3300	100	5.200

20HH 820 (M8)	20	5	800/1100	300	6.500	20HH 845 (M8)	45	12	1800/2500	300	4.548
20HH 825 (M8)	25	7	1000/1400	200	6.000	20HH 850 (M8)	50	17	2000/2800	100	7.000
20HH 830 (M8)	30	9	1200/1600	200	6.500	20HH 860 (M8)	60	17	2400/3300	100	7.500
20HH 835 (M8)	35	9	1400/1900	200	7.800						

Hex Face to Face (A/F 25mm)

25HH 625 (M6)	25	7	1000/1400	100	3.232	25HH 825 (M8)	25	7	1000/1400	100	4.000
25HH 630 (M6)	30	9	1200/1600	100	3.784	25HH 830 (M8)	30	9	1200/1600	100	4.137
25HH 635 (M6)	35	12	1400/1900	100	4.525	25HH 835 (M8)	35	12	1400/1900	100	4.880
25HH 640 (M6)	40	12	1600/2200	100	5.500	25HH 840 (M8)	40	12	1600/2200	100	5.392
25HH 645 (M6)	45	12	1800/2500	100	5.800	25HH 845 (M8)	45	12	1800/2500	100	6.300
25HH 650 (M6)	50	12	2000/2800	50	3.025	25HH 850 (M8)	50	17	2000/2800	50	3.475
25HH 655 (M6)	55	12	2200/3000	50	3.235	25HH 855 (M8)	55	17	2200/3000	50	3.709
25HH 660 (M6)	60	12	2400/3300	50	3.497	25HH 860 (M8)	60	17	2400/3300	50	3.928
25HH 680 (M6)	80	12	3200/4400	50	4.210	25HH 1030 (M10)	30	9	1200/1600	100	4.500
25HH 6100 (M6)	100	12	4000/5600	50	4.680						

Hex Face to Face (A/F 35mm)

35HH 830 (M8)	30	9	1200/1600	50	3.486	35HH 1030 (M10)	30	9	1200/1600	50	3.743
35HH 835 (M8)	35	12	1400/1900	50	4.078	35HH 1035 (M10)	35	12	1400/1900	50	4.200
35HH 840 (M8)	40	12	1600/2200	50	4.524	35HH 1040 (M10)	40	12	1600/2200	50	4.705
35HH 845 (M8)	45	12	1800/2500	50	5.110	35HH 1045 (M10)	45	12	1800/2500	50	5.300
35HH 850 (M8)	50	17	2000/2800	50	5.778	35HH 1050 (M10)	50	17	2000/2800	50	5.998
35HH 855 (M8)	55	17	2200/3000	25	3.500	35HH 1055 (M10)	55	17	2200/3000	25	3.312
35HH 860 (M8)	60	17	2400/3300	25	3.800	35HH 1060 (M10)	60	17	2400/3300	25	3.510

Hex Face to Face (A/F 45mm)

45HH 1035 (M10)	35	12	1400/1900	50	6.400	45HH 1235 (M12)	35	12	1400/1900	50	6.600
45HH 1040 (M10)	40	12	1600/2200	50	7.200	45HH 1240 (M12)	40	12	1600/2200	50	7.400
45HH 1045 (M10)	45	12	1800/2500	50	7.800	45HH 1245 (M12)	45	12	1800/2500	50	8.000
45HH 1050 (M10)	50	17	2000/2800	50	9.200	45HH 1250 (M12)	50	17	2000/2800	50	9.400
45HH 1055 (M10)	55	17	2200/3000	25	5.200	45HH 1255 (M12)	55	17	2200/3000	25	5.500
45HH 1060 (M10)	60	17	2400/3300	25	5.480	45HH 1260 (M12)	60	17	2400/3300	25	5.700
45HH 1070 (M10)	70	22	2800/3900	25	6.500	45HH 1270 (M12)	70	22	2800/3900	25	6.800
45HH 1080 (M10)	80	22	3200/4400	25	7.500	45HH 1280 (M12)	80	22	3200/4400	25	7.800
45HH 1090 (M10)	90	22	3600/5000	25	8.500	45HH 1290 (M12)	90	22	3600/5000	25	8.800
45HH 10100 (M10)	100	22	4000/5600	25	9.600	45HH 12100 (M12)	100	22	4000/5600	25	9.800

Hex Face to Face (A/F 55mm)

55HH 1050 (M10)	50	17	2000/2800			55HH 1060 (M10)	60	17	2400/3300		
-----------------	----	----	-----------	--	--	-----------------	----	----	-----------	--	--

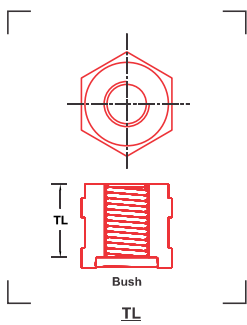
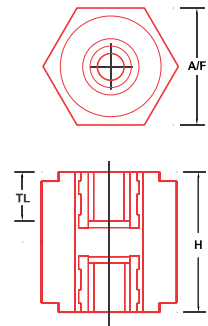
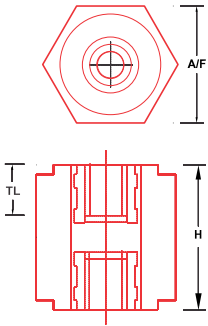

- Material : DMC (Dough Moulding Compound) UL File No. QEUY2.E249670 (Halogen Free)
- Product : UL Certification File No. QEUY2.E314972
- All Dimensions are in MM
- TL : Effective Thread Length
- All Insulators are certified

- Insert : Aluminium / Brass / Steel (Zinc Passivated) / Stainless Steel
- Mounting Detail on Page No. 80
- Insert Material detail on page no. 83
- For maximum torque please see page no. 83

- For technical details of Busbar support & Insulator, please refer POWERMAT TECHNICAL NOTES - 02/18.
- For checking the suitability of a support & insulator for a fault current, please ask for POWERMAT FAULT LEVEL CALCULATOR Software.

Round Hex

Part No. (Insert)	Height (H) (mm)	TL (mm)	Nominal Voltage (AC / DC)	Std. Pkg. (Nos.)	Box Wt. (Kg.)	Part No. (Insert)	Height (H) (mm)	TL (mm)	Nominal Voltage (AC / DC)	Std. Pkg. (Nos.)	Box Wt. (Kg.)
-------------------	-----------------	---------	---------------------------	------------------	---------------	-------------------	-----------------	---------	---------------------------	------------------	---------------

Hex Face to Face (A/F 20mm)

20RH 520 (M5)	20	5	800/1100	300	6.500	20RH 525 (M5)	25	7	1000/1400	300	5.600
20RH 620 (M6)	20	5	800/1100	300	6.808	20RH 830 (M8)	30	9	1200/1600	200	6.500
20RH 625 (M6)	25	7	1000/1400	200	5.673	20RH 835 (M8)	35	12	1400/1900	200	7.000
20RH 630 (M6)	30	7	1200/1600	200	5.800	20RH 840 (M8)	40	12	1600/2200	200	7.800
20RH 635 (M6)	35	9	1400/1900	200	6.680	20RH 845 (M8)	45	12	1800/2500	100	5.000
20RH 640 (M6)	40	12	1600/2200	200	7.000	20RH 850 (M8)	50	17	2000/2800	100	5.500
20RH 645 (M6)	45	12	1800/2500	100	4.200						
20RH 650 (M6)	50	12	2000/2800	100	4.800						

Hex Face to Face (A/F 30mm)

30RH 830 (M8)	30	9	1200/1600	100	5.700	30RH 1030 (M10)	30	9	1200/1600	100	6.000
30RH 835 (M8)	35	12	1400/1900	100	6.000	30RH 1035 (M10)	35	12	1400/1900	100	6.400
30RH 840 (M8)	40	12	1600/2200	100	7.000	30RH 1040 (M10)	40	12	1600/2200	100	7.500

Hex Face to Face (A/F 40mm)

40RH 1030 (M10)	30	9	1200/1600	50	3.500	40RH 1240 (M12)	40	12	1600/2200	50	6.000
40RH 1035 (M10)	35	12	1400/1900	50	4.500	40RH 1245 (M12)	45	12	1800/2500	50	6.500
40RH 1040 (M10)	40	12	1600/2200	50	6.000	40RH 1250 (M12)	50	17	2000/2800	50	7.500
40RH 1045 (M10)	45	12	1800/2500	25	3.400	40RH 1255 (M12)	55	17	2200/3000	25	4.400
40RH 1050 (M10)	50	17	2000/2800	25	3.842	40RH 1260 (M12)	60	17	2400/3300	25	4.600
40RH 1055 (M10)	55	17	2200/3000	25	4.200	40RH 1265 (M12)	65	17	2600/3600	25	5.200
40RH 1060 (M10)	60	17	2400/3300	25	4.500	40RH 1270 (M12)	70	22	2800/3900	25	5.500
40RH 1065 (M10)	65	17	2600/3600	25	5.200						
40RH 1070 (M10)	70	22	2800/3900	25	5.500						

Hex Face to Face (A/F 60mm)

60RH 1040 (M10)	40	12	1600/2200	20	5.300	60RH 1240 (M12)	40	12	1600/2200	20	5.400
60RH 1050 (M10)	50	17	2000/2800	10	3.400	60RH 1250 (M12)	50	17	2000/2800	10	3.600
60RH 1060 (M10)	60	17	2400/3300	10	3.800	60RH 1260 (M12)	60	17	2400/3300	10	4.200
60RH 1070 (M10)	70	22	2800/3900	10	4.200	60RH 1270 (M12)	70	22	2800/3900	10	4.360
60RH 1650 (M16)	50	17	2000/2800	10	3.800	60RH 1280 (M12)	80	22	3200/4400	10	5.200
60RH 1660 (M16)	60	17	2400/3300	10	4.500						
60RH 1670 (M16)	70	22	2800/3900	10	5.000						
60RH 1680 (M16)	80	26	3200/4400	10	5.400						

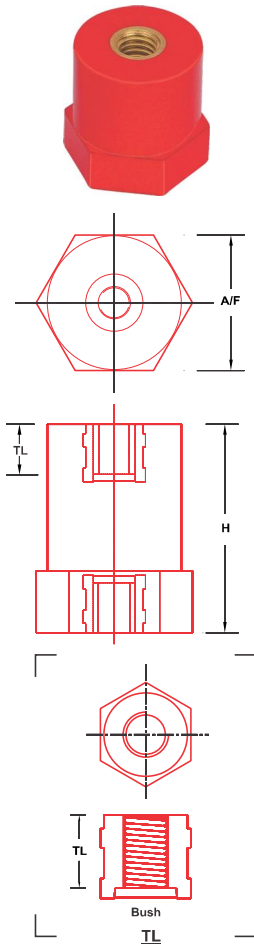

POWERMAT code	H (mm)	Insert I (2 nos.)	Dimension Insert II (1 no.)	Dimension Insert III (1 no.)	TL mm	Nominal Voltage (AC / DC)	Std. Pkg. (Nos.)	Box Wt. (Kg.)
PD50RH35	35	M8 x 15	-	M8 x 15	12	1400/1900	20	4.800
PD60RH40	40	M8 x 15	M10 x 15	M12 x 15	12	1600/2200	20	5.400
PD60RH50	50	M8 x 20	M10 x 20	M12 x 20	17	2000/2800	10	3.500
PD60RH60	60	M8 x 20	M10 x 20	M12 x 20	17	2400/3300	10	3.800
PD60RH70	70	M8 x 20	M10 x 20	M12 x 25	22	2800/3900	10	4.300
PD60RH80	80	M8 x 20	M10 x 25	M12 x 25	22	3200/4400	10	5.500

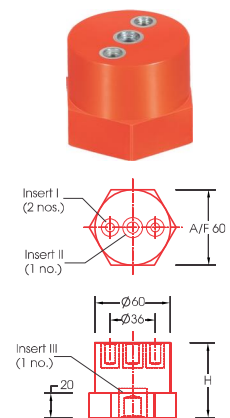

- Material : DMC (Dough Moulding Compound) UL File No. QEU2.E249670 (Halogen Free)
- Product : UL Certification File No. QEU2.E314972
- All Dimensions are in MM
- TL : Effective Thread Length
- All Insulators are CE certified

- Insert : Aluminium / Brass / Steel (Zinc Passivated) / Stainless Steel
- Mounting Detail on Page No. 80
- Insert Material detail on page no. 83
- For maximum torque please see page no. 83

- For technical details of Busbar support & Insulator, please refer POWERMAT TECHNICAL NOTES - 02/18.
- For checking the suitability of a support & insulator for a fault current, please ask for POWERMAT FAULT LEVEL CALCULATOR Software.

RH Series (Male - Male Combination)

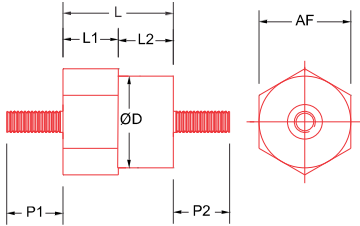

Part No.	AF mm	Ø D mm	L mm	L1 mm	L2 mm	P1 mm	P2 mm
----------	-------	--------	------	-------	-------	-------	-------

Hex Face to Face (A/F 10mm)

RH10.12-HM3.05RM3.05	10	10	12	6	6	M3X5	M3X5
RH11.11-HM3.10RM3.10	11	11	11	6	5	M3X10	M3X10

Hex Face to Face (A/F 14mm)

RH14.14-HM3.10RM3.10	14	14	14	6	8	M3X10	M3X10
RH14.14-HM4.10RM3.10	14	14	14	6	8	M4X10	M3X10
RH14.14-HM4.10RM4.10	14	14	14	6	8	M4X10	M4X10
RH14.14-HM4.10RM6.10	14	14	14	6	8	M4X10	M6X10
RH14.14-HM5.10RM5.10	14	14	14	6	8	M5X10	M5X10
RH14.14-HM6.10RM6.10	14	14	14	6	8	M6X10	M6X10
RH14.14-HM6.10RM6.15	14	14	14	6	8	M6X10	M6X15
RH14.26-HM5.10RM5.10	14	14	26	8	18	M5X10	M5X10

Hex Face to Face (A/F 21mm)

RH21.26-HM8.20RM8.08	21	20	26	8	18	M8X20	M8X08
RH21.35-HM8.10RM8.15	21	20	35	17	18	M8X10	M8X15

RH Series (Male - Female Combination)

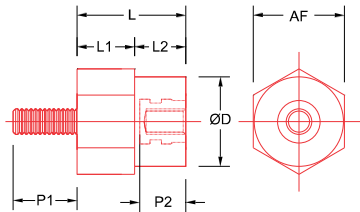
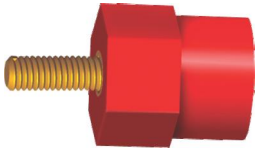

Part No.	AF mm	Ø D mm	L mm	L1 mm	L2 mm	P1 mm	P2 mm
----------	-------	--------	------	-------	-------	-------	-------

Hex Face to Face (A/F 14mm)

RH14.17-HM4.07RF4.07	14	14	17	9	8	M4X7	M4X7
RH14.17-HM4.10RF4.10	14	14	17	9	8	M4X10	M4X10
RH14.17-HM6.10RF6.10	14	14	17	9	8	M6X10	M6X10
RH14.17-HM5.10RF5.10	14	14	17	9	8	M5X10	M5X10

Hex Face to Face (A/F 21mm)

RH21.26-HF8.08RM8.10	21	20	26	8	18	M8X8	M8X10
----------------------	----	----	----	---	----	------	-------

RH Series (Female - Female Combination)

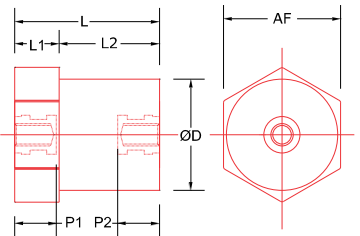
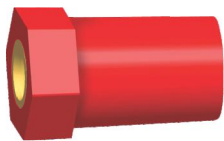

Part No.	AF mm	Ø D mm	L mm	L1 mm	L2 mm	P1 mm	P2 mm
----------	-------	--------	------	-------	-------	-------	-------

Hex Face to Face (A/F 21mm)

RH21.26-HF6.08RF6.08	21	20	26	8	18	M6X8	M6X8
RH21.26-HF8.08RF6.08	21	20	26	8	18	M8X8	M6X8
RH21.26-HF8.08RF8.08	21	20	26	8	18	M8X8	M8X8
RH21.35-HF6.08RF6.08	21	20	35	17	18	M6X8	M6X8
RH21.35-HF8.08RF8.08	21	20	35	17	18	M8X8	M8X8
RH21.35-HF8.10RF8.10	21	20	35	17	18	M8X8	M8X8

- Material : DMC (Dough Moulding Compound)  UL File No. QEUY2.E249670 (Halogen Free)
- All Dimensions are in MM
- TL : Effective Thread Length
- All Insulators are  certified

- Insert : Aluminium / Brass / Steel (Zinc Passivated) / Stainless Steel
- Mounting Detail on Page No. 80
- Insert Material detail on page no. 83
- For maximum torque please see page no. 83

- For technical details of Busbar support & Insulator, please refer POWERMAT TECHNICAL NOTES - 02/18.
- For checking the suitability of a support & insulator for a fault current, please ask for POWERMAT FAULT LEVEL CALCULATOR Software.

Standoff Insulators

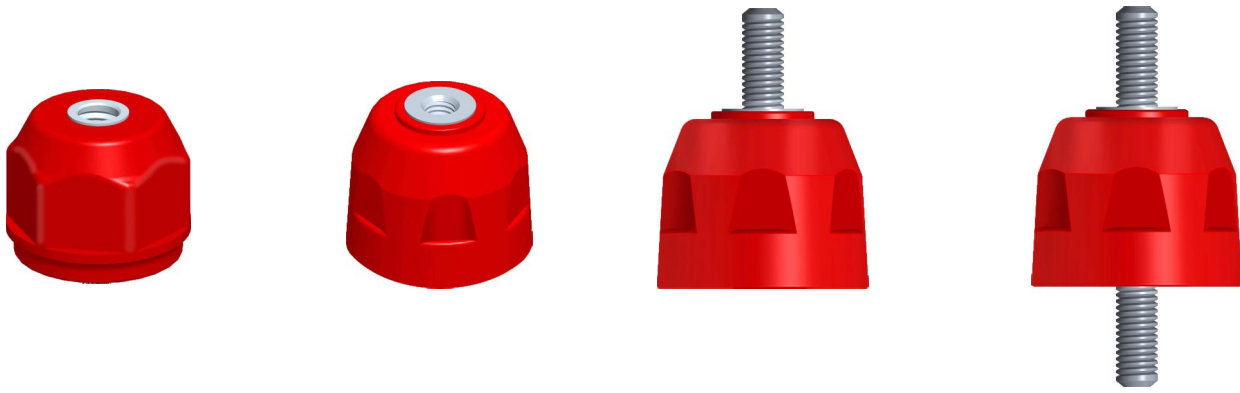

WT Series

Product Code	H (mm)	P1	P2	Std. Pkg. (Nos.)	Box Wt. (Kg.)
WT0516-F0506.F0506	16	M05 x 06	M05 x 06	400	2.654
WT0516-M0506.F0506	16	M05 x 06	M05 x 06	400	2.800
WT0516-M0506.M0506	16	M05 x 06	M05 x 06	400	3.200
WT0626-F0610.F0610	26	M06 x 10	M06 x 10	200	2.500
WT0626-M0610.F0610	26	M06 x 10	M06 x 10	200	2.950
WT0626-M0610.M0610	26	M06 x 10	M06 x 10	200	3.400
WTMSS0635-F0615.F0615	35	M06 x 15	M06 x 15	100	4.525
WTMSS0635-M0615.F0615	35	M06 x 15	M06 x 15	100	4.900
WTMSS0635-M0615.M0615	35	M06 x 15	M06 x 15	100	5.225
WTMSS0835-F0815.F0815	35	M08 x 15	M08 x 15	100	4.750
WTMSS0835-M0815.F0815	35	M08 x 15	M08 x 15	100	5.250
WTMSS0835-M0815.M0815	35	M08 x 15	M08 x 15	100	5.750
WTMSS1035-F1015.F1015	35	M10 x 15	M10 x 15	100	4.850
WTMSS1035-M1015.F1015	35	M10 x 15	M10 x 15	100	5.350
WTMSS1035-M1015.M1015	35	M10 x 15	M10 x 15	100	5.900
WT0635-F0615.F0615	35	M06 x 15	M06 x 15	100	4.500
WT0635-M0615.F0615	35	M06 x 15	M06 x 15	100	5.250
WT0635-M0615.M0615	35	M06 x 15	M06 x 15	100	6.000
WT0835-F0815.F0815	35	M08 x 15	M08 x 15	100	4.750
WT0835-M0815.F0815	35	M08 x 15	M08 x 15	100	5.500
WT0835-M0815.M0815	35	M08 x 15	M08 x 15	100	6.250
WT1035-F1015.F1015	35	M10 x 15	M10 x 15	100	5.250
WT1035-M1015.F1015	35	M10 x 15	M10 x 15	100	6.250
WT1035-M1015.M1015	35	M10 x 15	M10 x 15	100	7.250
WT1050-F1020.F1020	50	M10 x 20	M10 x 20	50	9.200
WT1050-M1020.F1020	50	M10 x 20	M10 x 20	50	10.350
WT1050-M1020.M1020	50	M10 x 20	M10 x 20	50	11.500

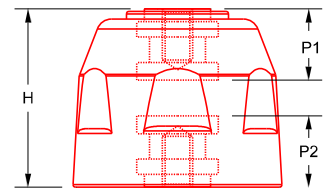

Female-Female Combination

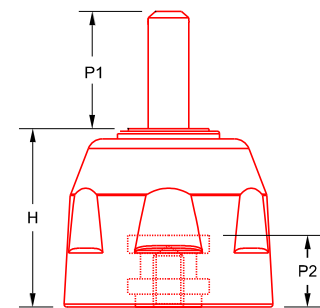

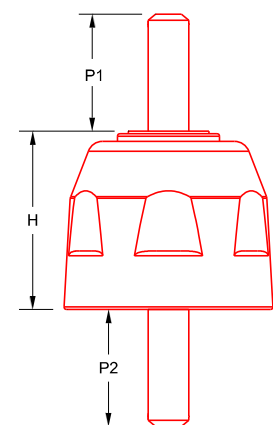

Male-Female Combination



Male-Male Combination

* **F-F** Stands for Female - Female Combination
M-F Stands for Male - Female Combination
M-M Stands for Male - Male Combination

- Material : DMC (Dough Moulding Compound)  UL File No. QEU2.E249670 (Halogen Free)
- All Dimensions are in MM
- TL : Effective Thread Length
- All Insulators are  certified
- Insert : Aluminium / Brass / Steel (Zinc Passivated) / Stainless Steel
- Mounting Detail on Page No. 80
- Insert Material detail on page no. 83
- For maximum torque please see page no. 83
- For technical details of Busbar support & Insulator, please refer POWERMAT TECHNICAL NOTES - 02/18.
- For checking the suitability of a support & insulator for a fault current, please ask for POWERMAT FAULT LEVEL CALCULATOR Software.

Standoff Insulators

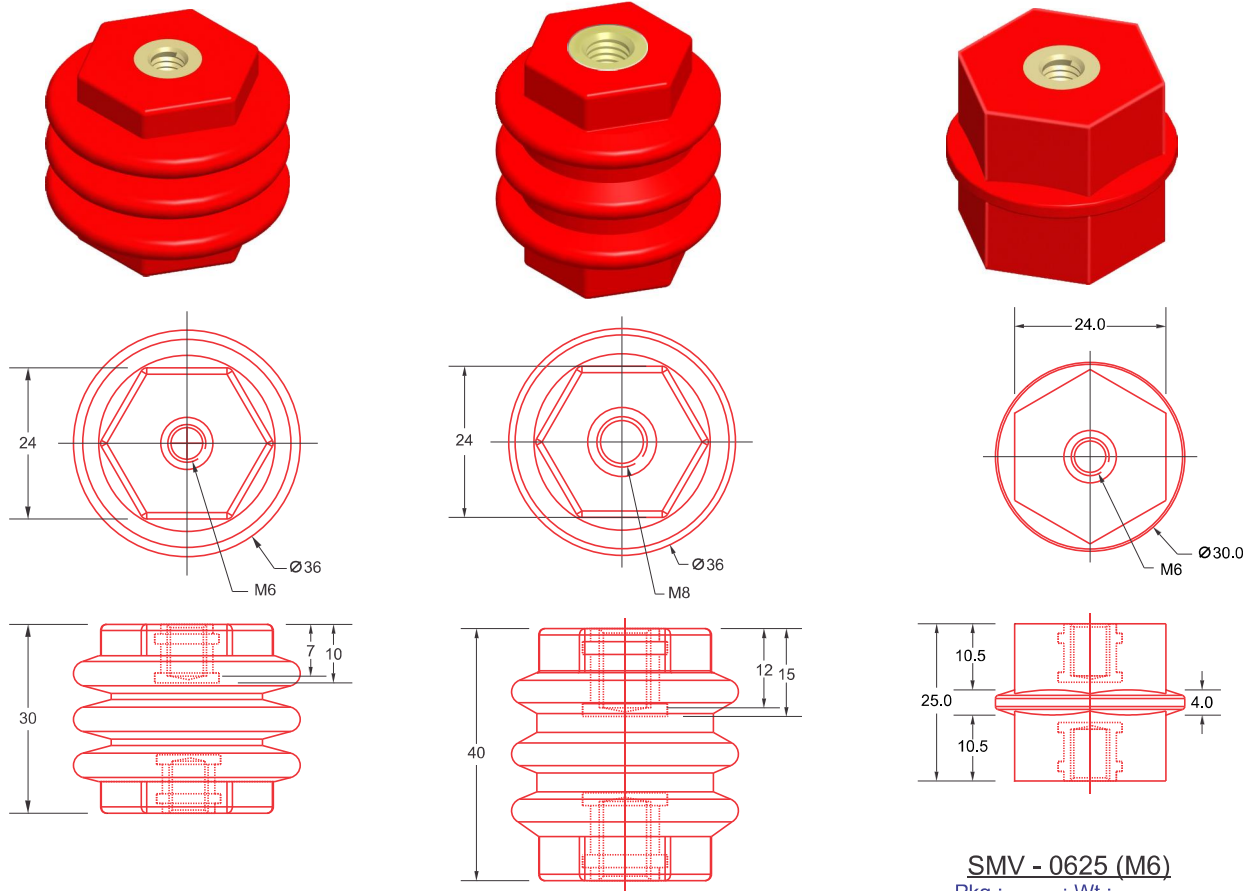

SMV - 0630 (M6)
Pkg.: ; Wt.:

SMV - 0830 (M8)
Pkg.: ; Wt.:

SMV - 0625 (M6)
Pkg.: ; Wt.:

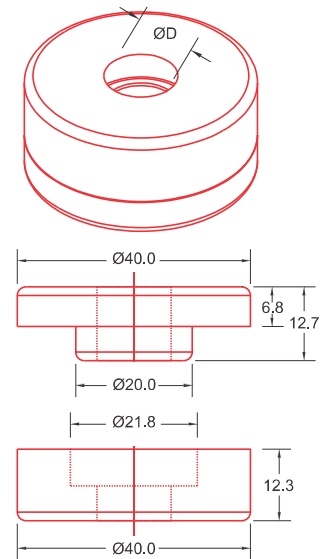
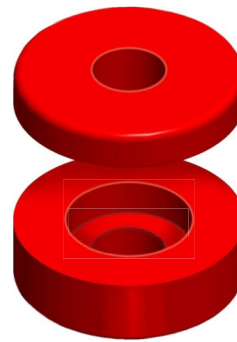
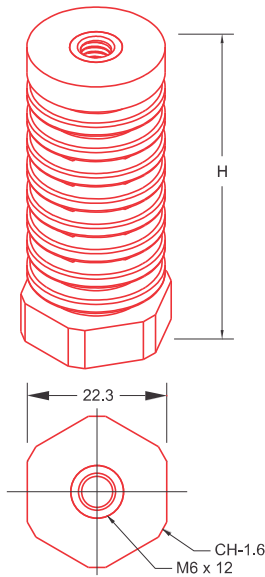



TUBULAR INSULATOR

PART CODE	H (mm)	Std. Pkg. (Nos.)	Box Wt. (Kg.)
TBI - 50	50	25	3.250
TBI - 55	55	25	3.800

EARTHING SUPPORT

PART CODE	ØD	Std. Pkg. (Nos.)	Box Wt. (Kg.)
ES - 2040 12	12.75	100	1.200
ES - 2040 10	10.20	100	1.000
ES - 2040 08	8.20	100	0.800

- Material : Cast Resin / DMC (Dough Moulding Compound)  UL File No. QEU2.E249670 (Halogen Free)
- ++ same insert configuration on both sides
- All Dimensions are in MM
- Insert : Brass / Mild Steel (Zinc Passivated) / SS / AL.
- Insert Material detail on page no. 83
- All Insulators are  certified
- For technical details of Busbar support & Insulator, please refer POWERMAT TECHNICAL NOTES - 02/18.
- For checking the suitability of a support & insulator for a fault current, please ask for POWERMAT FAULT LEVEL CALCULATOR Software.

H.T. Insulators

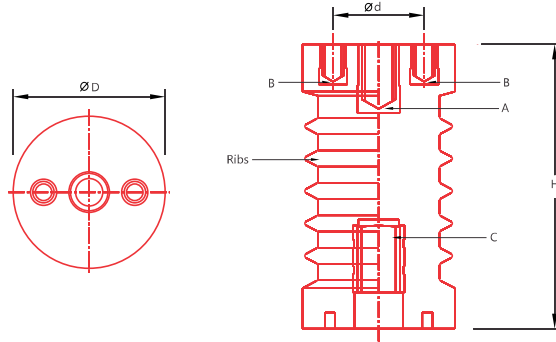

PRODUCT CODE	HEIGHT mm	VOLTAGE RATING	RIBS (Nos.)	CREEPAGE mm	Ø D mm	Ø d mm	A	INSERTS B	C	Std. Pkg. (Nos.)	Box Wt. (Kg.)
MV 5035	35	1.6 Kv	4	48	50	25	-	M-08 X 15 Lg	C = B	25	-
MV 7535	35	1.6 Kv	4	67	75	30	-	M-10 X 15 Lg	C = B	-	-
MV 6040	40	3.5 Kv	1	55	60	36	M-10 X 15 Lg	M-08 X 12 Lg	M-10 X 15 Lg	20	4.800
MV 4050	50	3.5 Kv	1	55	40	-	M-10 X 15 Lg	-	M-10 X 15 Lg	25	-
MV 5050	50	3.5 Kv	4	65	50	25	-	M-08 X 20 Lg	C = B	-	-
MV 7550	50	3.5 Kv	4	82	75	30	-	M-10 X 20 Lg	C = B	-	-
MV 5560	60	5.5 Kv	1	78	55	28	-	M-08 X 15 Lg	C = B	-	-
MV 606560	60	5.5 Kv	2	90	60/65	36	M-12 X 20 Lg	M-08 X 20 Lg	M-12 X 20 Lg	10	3.800
MV 859060	60	5.5 Kv	2	90	85/90	60	M-16 X 20 Lg	M-10 X 20 Lg	M-16 X 20 Lg	10	7.000
MV 6075	75	6.8 Kv	2	112	60	36	M-10 X 20 Lg	M-06 X 15 Lg	M-12 X 25 Lg	10	3.944
PDMV 6075	75	6.8 Kv	2	112	60	36	M-10 X 20 Lg	M-08 X 15 Lg	M-12 X 25 Lg	10	4.000
MV 9580	80	6.8 Kv	1	92	90	55	-	M-10 X 20 Lg	M-16 X 30 Lg	-	-
MV 7590	90	8.5 Kv	3	132	75	40	M-10 X 20 Lg	2 X M8/M10 X 15	C = A, B	-	-
MV 6090	90	8.5 Kv	3	140	60	36	M-10 X 20 Lg	M-06 X 15 Lg	M-12 X 25 Lg	10	4.443
PDMV 6090	90	8.5 Kv	3	140	60	36	M-10 X 20 Lg	M-08 X 15 Lg	M-12 X 25 Lg	10	4.500
MV 9011082	110	12 Kv	4	209	82/90	40	-	M-10 X 15 Lg	M-12 X 20 Lg	-	-
MV 60130	130	12 Kv	5	200	60	36	M-12 X 25 Lg	M-06 X 15 Lg	M-16 X 35 Lg	5	3.035
PDMV 60130	130	12 Kv	5	200	60	36	M-12 X 25 Lg	M-08 X 15 Lg	M-16 X 35 Lg	5	3.200
MV 75130	130	12 Kv	5	215	75	45	M-16 X 35 Lg	M-10 X 20 Lg	M-20 X 35 Lg	5	4.642
MV 75130/2*	130	12 Kv	5	215	75	45	M-12 X 25 Lg	M-08 X 20 Lg	A-B	5	4.700
MV 75130/7	130	12 Kv	7	256	75	45	M-16 X 35 Lg	M-10 X 20 Lg	M-20 X 40 Lg	5	4.700
MV 90130	130	12 Kv	7	372	90	36	-	M-16 X 35 Lg	M-20 X 40 Lg	-	-
MV 8614580	145	16 Kv	7	260	80/86	40	-	M-10 X 15 Lg	M-12 X 20 Lg	4	5.800
MV 90150	150	16 Kv	7	392	90	36	-	M-16 X 35 Lg	M-20 X 40 Lg	-	-
MV 70210	210	22 Kv	9	285	70	36	M-10 X 25 Lg	M-06 X 15 Lg	M-16 X 55 Lg	4	5.375
PDMV 70210	210	22 Kv	9	285	70	36	M-10 X 25 Lg	M-08 X 15 Lg	M-16 X 55 Lg	4	5.500
MV 70210/2	210	22 Kv	9	285	70	36	M-12 X 25 Lg	M-08 X 20 Lg	A-B	4	5.500
MV 80300	300	35 Kv	12	450	80	36	M-10 X 25 Lg	M-06 X 15 Lg	M-16 X 75 Lg	2	4.717
PDMV 80300	300	35 Kv	12	450	80	36	M-10 X 25 Lg	M-08 X 15 Lg	M-16 X 75 Lg	2	4.800
MV 95300	300	35 Kv	12	630	95	46	M-16 X 55 Lg	M-10 X 20 Lg	M-22 X 65 Lg	2	5.800

* Material : Cast Resin / DMC (Dough Moulding Compound)  UL File No. QEUY2.E249670 (Halogen Free)

** same insert configuration on both sides

• All Dimensions are in MM

• Insert : Brass / Mild Steel (Zinc Passivated)

• Insert Material detail on page no. 83

• All Insulators are  certified

• For technical details of Busbar support & Insulator, please refer POWERMAT TECHNICAL NOTES - 02/18.

• For checking the suitability of a support & insulator for a fault current, please ask for POWERMAT FAULT LEVEL CALCULATOR Software.

Insulator for Vertical Bars

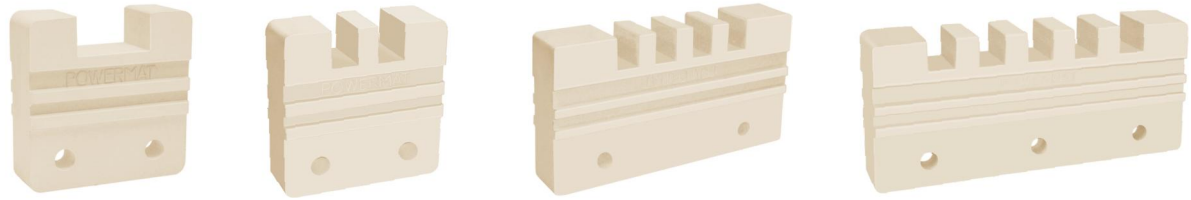

Finger- Supports

Busbar	POWERMAT code	Dimension							Std. Pkg. (Nos.)	Box Wt. (Kg.)
		A max	B	C	D	E	F max	Sd		

Single Way

6mm x 1R	106S	7	50	22	14	10	-	15	50	3.182
10mm x 1R	110S	11	50	22	14	10	-	15	50	3.103
12mm x 1R	112S	13.7	50	22	14	10	-	15	50	3.098
6mm x 1R	106W	7	60	32	14	10	-	15	50	3.980
10mm x 1R	110W	11	60	32	14	10	-	15	50	3.913
12mm x 1R	112W	13.7	60	32	14	10	-	15	50	3.902
6mm x 1R	106K	7	70	40	20	16	-	15	50	7.000
10mm x 1R	110K	11	70	40	20	16	-	15	50	6.860
12mm x 1R	112K	13.7	70	40	20	16	-	15	50	6.960
6mm x 1R	106T	7	70	40	25	20	-	15	40	7.800
10mm x 1R	110T	11	70	40	25	20	-	15	40	7.700
12mm x 1R	112T	13.7	70	40	25	20	-	15	40	7.600

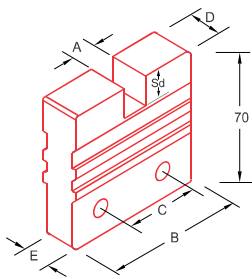

Two Way

6mm x 2R	206W	7.1	60	32	14	10	5.6	15	50	3.700
10mm x 2R	210W	11	60	32	14	10	9.6	15	50	3.685
12mm x 2R	212W	13.7	70	32	14	10	11	15	50	4.328
6mm x 2R	206K	7.1	70	40	20	16	5.6	15	50	6.800
	119K	19.8	70	40	20	16	-	15	50	6.600
10mm x 2R	210K	11	70	40	20	16	9	15	50	6.540
	131K	31.2	70	40	20	16	-	15	50	6.400
12mm x 2R	212K	13.7	70	40	20	16	11	15	50	6.420
	137K	38.4	70	40	20	16	-	15	50	6.000
6mm x 2R	206T	7.1	70	40	25	20	5.6	15	40	7.600
	119T	19.8	70	40	25	20	-	15	40	7.500
10mm x 2R	210T	10.8	70	40	25	20	9.6	15	40	7.500
	131T	31.2	70	40	25	20	-	15	40	7.200
12mm x 2R	212T	13.7	70	40	25	20	11	15	40	7.400
	137T	38.4	70	40	25	20	-	15	40	7.100

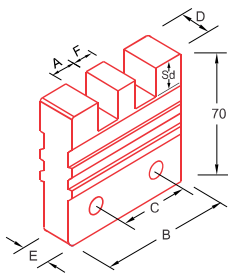

Three Way

6mm x 3R	306W	7	70	32	14	10	5.4	15	50	4.397
10mm x 3R	310W	11	80	50	14	10	8.6	15	50	6.200
12mm x 3R	312W	13.2	90	50	15	11	11	15	50	6.060
6mm x 3R	306K	7	70	40	20	16	5.4	15	50	6.600
10mm x 3R	310K	11	100	50	20	16	9.4	15	20	3.868
	151K	51.6	100	50	20	16	-	15	20	3.800
12mm x 3R	312K	13.2	100	50	20	16	10.5	15	20	3.831
6mm x 3R	306T	7	70	40	25	20	5.4	15	40	7.600
10mm x 3R	310T	11	100	50	25	20	9.4	15	18	7.800
	151T	51.6	100	50	25	20	-	15	18	4.700
12mm x 3R	312T	13.2	100	50	25	20	11.4	15	18	4.600

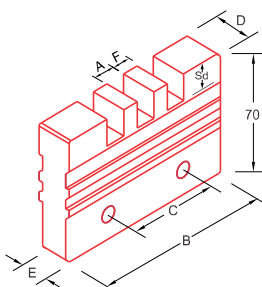

- Material : SMC (Sheet Moulding Compound) / DMC (Dough Moulding Compound)  UL File No. QEU2.E249670 (Halogen Free)
- All Dimensions are in MM
- Mounting Hole \varnothing 8.5 mm
- All Insulators are  certified
- Sd - Depth of Slot
- Mounting Detail on Page No. 80

- For technical details of Busbar support & Insulator, please refer POWERMAT TECHNICAL NOTES - 02/18.
- For checking the suitability of a support & insulator for a fault current, please ask for POWERMAT FAULT LEVEL CALCULATOR Software.

Insulator for Vertical Bars

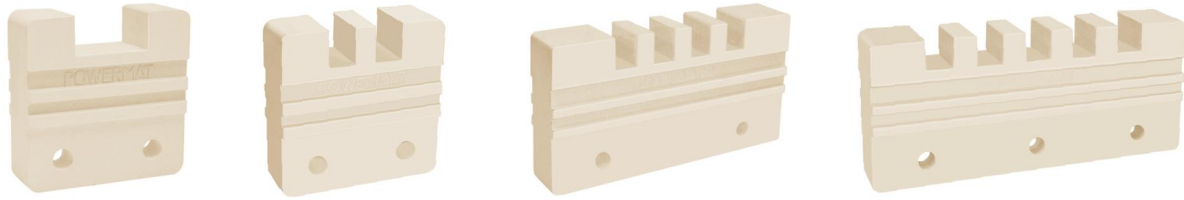

Finger- Supports

Busbar	POWERMAT code	Dimension							Std. Pkg. (Nos.)	Box Wt. (Kg.)
		A max	B	C	D	E	F max	Sd		

Four Way

6mm x 4R	406W	7.2	80	50	14	10	5.6	15	50	5.460
6mm x 4R	406K	7.2	100	50	20	16	5.6	15	20	3.904
10mm x 4R	410K	11.2	130	80	20	16	9.6	15	20	5.100
	172K	72	130	80	20	16	-	15	20	4.800
12mm x 4R	412K	13.4	130	80	20	16	11.6	15	20	4.948
10mm x 4R	410T	11.2	130	80	25	20	9.6	15	20	4.800
	172T	72	130	80	25	20	-	15	20	4.800
12mm x 4R	412T	13.4	130	80	25	20	11.6	15	20	4.800

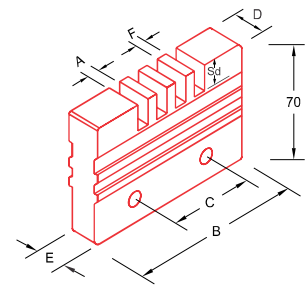

Five Way

6mm x 5R	506K	7.4	100	50	20	16	5.4	15	20	4.200
10mm x 5R	510K	11.4	160	55/55	20	16	9.4	15	20	5.100
12mm x 5R	512K	13.7	160	55/55	20	16	11.4	15	20	5.000
6mm x 5R	506T	7.4	100	50	25	20	5.4	15	18	4.200
10mm x 5R	510T	11.4	160	55/55	25	20	9.4	15	18	5.800
12mm x 5R	512T	13.7	160	55/55	25	20	11.4	15	18	5.800

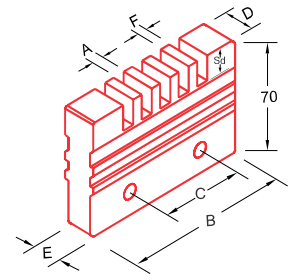

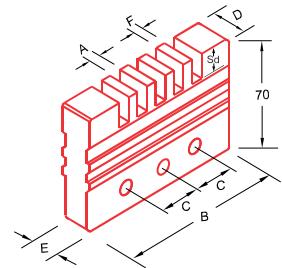

Six Way

6mm x 6R	606K	7.6	100	50	20	16	5.6	15	20	3.735
10mm x 6R	610K	11.6	160	55/55	20	16	9.6	15	20	5.100
12mm x 6R	612K	13.9	160	55/55	20	16	11.6	15	20	5.000
6mm x 6R	606T	7.6	100	50	25	20	5.6	15	18	4.000
10mm x 6R	610T	11.6	160	55/55	25	20	9.6	15	18	5.600
12mm x 6R	612T	13.9	160	55/55	25	20	11.6	15	18	5.600



Eight Way

6mm x 8R	806K	8	130	80	25	20	5.6	15	-	4.800
----------	------	---	-----	----	----	----	-----	----	---	-------

- Material : SMC (Sheet Moulding Compound) / DMC (Dough Moulding Compound)  UL File No. QEUY2.E249670 (Halogen Free)
- All Dimensions are in MM
- Mounting Hole \varnothing 8.5 mm
- All Insulators are  certified
- For technical details of Busbar support & Insulator, please refer POWERMAT TECHNICAL NOTES - 02/18.
- For checking the suitability of a support & insulator for a fault current, please ask for POWERMAT FAULT LEVEL CALCULATOR Software.

Polyamide Series



Finger Supports-N Series (Polyamide)

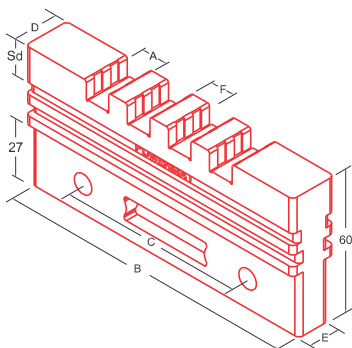
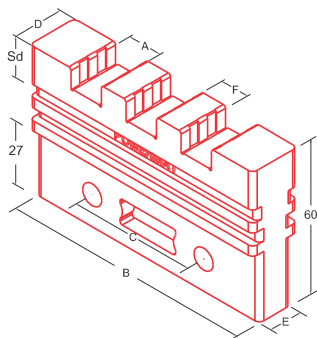
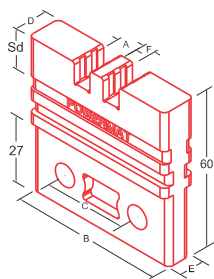
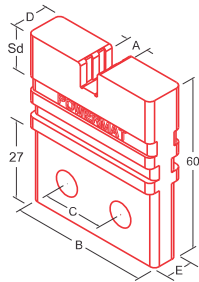

N1 Series

Busbar Details	POWERMAT Code	A	B	C	D	E	F	Sd	Std. Pkg. (Nos.)	Box Wt. (Kg.)
6mm x 1 run	106 N1	7	50	22	13	9	-	8	50	1.841
10mm x 1 run	110 N1	11	50	22	13	9	-	8	50	1.800
12mm x 1 run	112 N1	13.7	50	22	13	9	-	8	50	1.795

N3 Series

6mm x 1 run	106 N3	7	60	32	13	9	-	8	50	2.185
10mm x 1 run	110 N3	11	60	32	13	9	-	8	50	2.180
12mm x 1 run	112 N3	13.7	60	32	13	9	-	8	50	2.145
6mm x 2 runs	206 N3	7	60	32	13	9	5.8	8	50	2.142
10mm x 2 runs	210 N3	11	60	32	13	9	9	8	60	2.556
12mm x 2 runs	212 N3	13.7	60	32	13	9	11.8	8	50	2.256

N4 Series

10mm x 3 runs	310 N4	11	85	50	13	9	9	8	30	1.827
12mm x 3 runs	312 N4	13.7	85	50	13	9	11	8	30	1.800
6mm x 4 runs	406 N4	7	85	50	13	9	5.6	8	30	1.827

N5 Series

6mm x 1 run	106 N5	7	70	40	20	14	-	8	50	3.940
10mm x 1 run	110 N5	11	70	40	20	14	-	8	50	3.900
12mm x 1 run	112 N5	13.7	70	40	20	14	-	8	50	3.943
6mm x 2 runs	206 N5	7	70	40	20	14	5.8	8	50	3.970
10mm x 2 runs	210 N5	11	70	40	20	14	9	8	50	3.875
12mm x 2 runs	212 N5	13.7	70	40	20	14	11	8	50	3.710
6mm x 3 runs	306 N5	7	70	40	20	14	5.8	8	50	3.900

N7 Series

10mm x 3 runs	310 N7	11	100	50	20	14	9	8	30	3.443
12mm x 3 runs	312 N7	13.7	100	50	20	14	11	8	20	2.281
6mm x 4 runs	406 N7	7.2	100	50	20	14	5.6	8	-	-
6mm x 6 runs	606 N7	7.2	100	50	20	14	5	8	20	2.278

N9 Series

10mm x 4 runs	410 N9	11	130	80	20	14	9	8	20	2.894
12mm x 4 runs	412 N9	13.7	130	80	20	14	11	8	20	2.832

- Material : Polyamide / Nylon 6/6 (17% Glass Filled)
- All Dimensions are in MM

- Mounting Hole Ø 8.5mm
- Mounting Detail on Page No. 80, 81

- For technical details of Busbar support & Insulator, please refer POWERMAT TECHNICAL NOTES - 02/18.
- For checking the suitability of a support & insulator for a fault current, please ask for POWERMAT FAULT LEVEL CALCULATOR Software.

Insulator for Vertical Bars

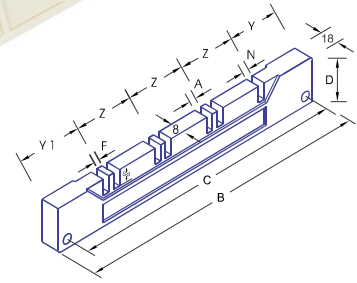
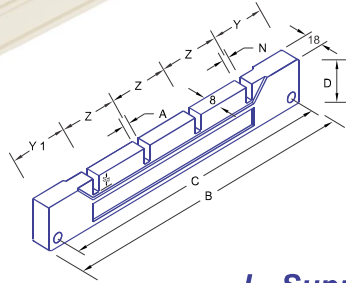
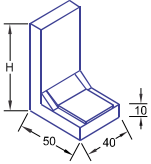
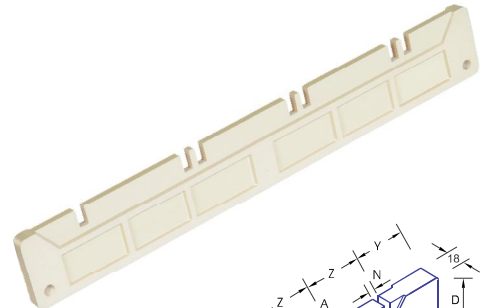
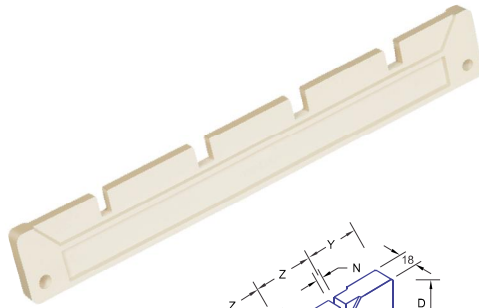

L- Supports

Height (H) mm	POWERMAT code	Std. Pkg. (Nos.)	Box Wt. (Kg.)
60	L 60	50	4.102
85	L 85	50	4.642
100	L 100	50	5.200
125	L 125	50	6.060

Busbar	POWERMAT code	Dimension										Std. Pkg. (Nos.)	Box Wt. (Kg.)
		A	B	C	D	N	Z	Y1	Y	F	Sd		
6mm x 1run/ph. & 6mm x 1 run/N	TPN 107/30	7	300	280	50	7	65	52.5	52.5	-	15	10	2.790
10mm x 1run/ph. & 6mm x 1 run/N	TPN 111/30	11	300	280	50	7	65	52.5	52.5	-	15	10	2.800
12mm x 1run/ph. & 6mm x 1 run/N	TPN 114/30	13.7	300	280	50	7	65	52.5	52.5	-	15	10	2.760
6mm x 1run/ph. & 6mm x 1 run/N	TPN 107/35	7	350	328	50	7	75	62.5	62.5	-	15	10	3.304
10mm x 1run/ph. & 6mm x 1 run/N	TPN 111/35	11	350	328	50	7	75	62.5	62.5	-	15	10	3.245
12mm x 1run/ph. & 6mm x 1 run/N	TPN 114/35	13.7	350	328	50	7	75	62.5	62.5	-	15	10	3.200
6mm x 1run/ph. & 6mm x 1 run/N	TPN 107/42	7	420	396	60	7	100	68	52	-	15	10	4.650
10mm x 1run/ph. & 6mm x 1 run/N	TPN 111/42	11	420	396	60	7	100	68	52	-	15	10	4.704
12mm x 1run/ph. & 6mm x 1 run/N	TPN 114/42	13.7	420	396	60	7	100	68	52	-	15	10	4.794
6mm x 1run/ph. & 6mm x 1 run/N	TPN 107/55	7	550	525	60	7	125	100	75	-	15	10	6.220
10mm x 1run/ph. & 6mm x 1 run/N	TPN 111/55	11	550	525	60	7	125	100	75	-	15	10	5.900
12mm x 1run/ph. & 6mm x 1 run/N	TPN 114/55	13.7	550	525	60	7	125	100	75	-	15	10	5.800
6mm x 2runs/ph. & 6mm x 1 run/N	TPN 207/35	7	350	328	50	7	70	78	62	5.8	15	10	3.400
10mm x 2runs/ph. & 10mm x 1 run/N	TPN 211/35	11	350	328	50	11	70	78	62	9	15	10	3.226
12mm x 2runs/ph. & 12mm x 1 run/N	TPN 214/35	13.7	350	328	50	13.7	70	78	62	11	15	10	3.100
6mm x 2runs/ph. & 6mm x 1 run/N	TPN 207/42	7	420	396	60	7	100	68	52	5.8	15	10	4.700
10mm x 2runs/ph. & 10mm x 1 run/N	TPN 211/42	11	420	396	60	11	100	68	52	9	15	10	4.600
12mm x 2runs/ph. & 12mm x 1 run/N	TPN 214/42	13.7	420	396	60	13.7	100	68	52	11	15	10	4.560
6mm x 2runs/ph. & 6mm x 1 run/N	TPN 207/55	7	550	525	60	7	125	100	75	5.8	15	10	6.800
10mm x 2runs/ph. & 10mm x 1 run/N	TPN 211/55	11	550	525	60	11	125	100	75	9	15	10	6.700
12mm x 2runs/ph. & 12mm x 1 run/N	TPN 214/55	13.7	550	525	60	13.7	125	100	75	11	15	10	6.600
6mm x 3 runs/ph.	TP 306/35	6	350	328	50	-	100	75	75	4.5	15	10	3.500
10mm x 2 runs/ph.	TP 211/35	11	350	328	50	-	100	75	75	9	15	10	3.500

- Material : SMC (Sheet Moulding Compound) / DMC (Dough Moulding Compound) UL File No. QEU2.E249670 (Halogen Free)
- All Dimensions are in MM
- All Insulators are certified
- Sd - Depth of Slot
- Mounting Detail on Page No. 83
- For technical details of Busbar support & Insulator, please refer POWERMAT TECHNICAL NOTES - 02/18.
- For checking the suitability of a support & insulator for a fault current, please ask for POWERMAT FAULT LEVEL CALCULATOR Software.

Insulator for Vertical Bars

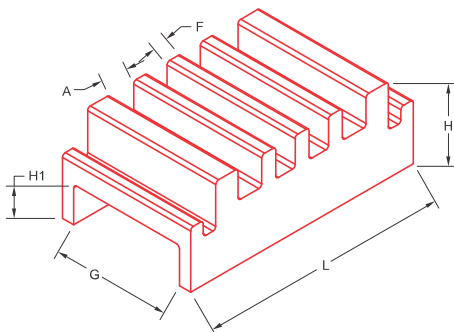
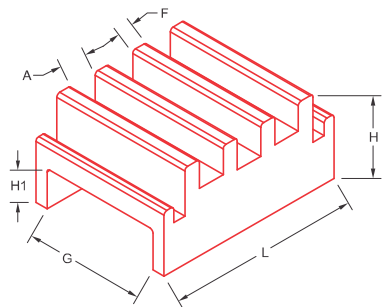
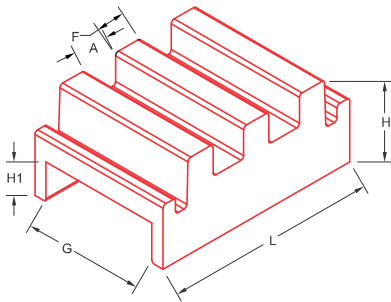
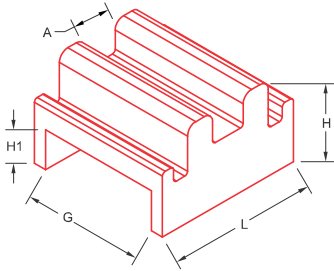
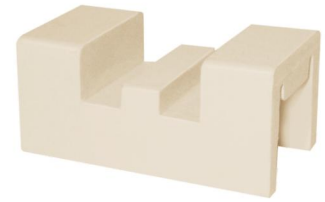
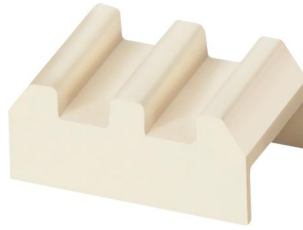
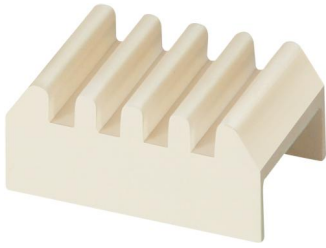

GP Series

Part No.	Busbar	Amax mm	C mm	F mm	G mm	H mm	L mm	H1 mm	Std. Pkg. (Nos.)	Box Wt. (Kg.)
GP - 106	6mm x 1R	7	20	-	38	30	47	12.5	50	2.500
GP - 110	10mm x 1R	11	20	-	38	30	47	12.5	50	2.404
GP - 206	6mm x 2R	7	25	5.5	38	30	52	12.5	50	2.665
GP - 210	10mm x 2R	11	30	9	38	30	67	12.5	50	3.668
GP - 306	6mm x 3R	8.5	30	5	38	30	61	12.5	50	3.500
GP - 406	6mm x 4R	8.5	50	5	38	30	80	12.5	50	4.093

GPS Series

Part No.	Busbar	Amax mm	C mm	F mm	G mm	H mm	L mm	H1 mm	Std. Pkg. (Nos.)	Box Wt. (Kg.)
GPS - 210	10mm x 2R	11	19	9	31	26.5	56	12.5	50	2.200
GPS - 212	12mm x 2R	12	19	8	31	30	56	12.5	50	2.460
GPS - 405	5mm x 4R	5.1	19	4.7	31	26.5	56	12.5	50	2.265
GPS - 406	6mm x 4R	7	19	5	31	30	67	12.5	50	2.800

GPB Series

Part No.	Busbar	Amax mm	C mm	F mm	G mm	H mm	L mm	H1 mm	Std. Pkg. (Nos.)	Box Wt. (Kg.)
GPB - 2498*	6mm x 2R	6	-	6	26	31	55	8	50	3.000
GPB - 2499*	10mm x 2R	10.3	-	9.9	26	31	64	8	50	3.590

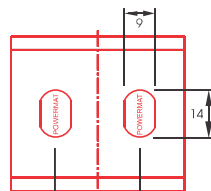

Bottom Side
GP Series

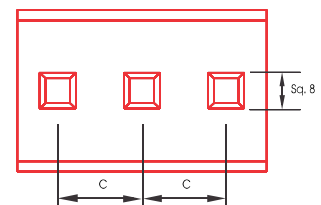

Bottom Side
GPS Series

- Material : SMC (Sheet Moulding Compound) / DMC (Dough Moulding Compound) UL File No. QEU2.E249670 (Halogen Free)
- All Dimensions are in MM
- Mounting Detail on Page No. 81
- All Insulators are CE certified

- For technical details of Busbar support & Insulator, please refer POWERMAT TECHNICAL NOTES - 02/18.
- For checking the suitability of a support & insulator for a fault current, please ask for POWERMAT FAULT LEVEL CALCULATOR Software.

Support for Vertical Bars

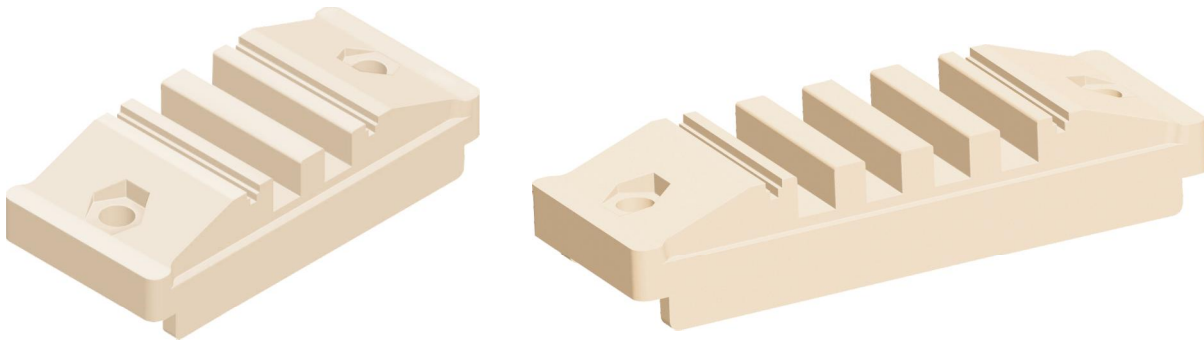

Busbar Details	POWERMAT Code	L mm	Cd mm	Dimensions		
				A mm	F mm	Sd mm
10mm x 2 run	132GP 210	132	100	10.8	9.6	12
12mm x 2 run	132GP 212	132	100	13.7	11	12
6mm x 3 run	132GP 306	132	100	7	5.4	12
10mm x 3 run	172GP 310	172	140	11	9.4	12
12mm x 3 run	172GP 312	172	140	13.2	11.4	12
10mm x 4 run	172GP 410	172	140	11.2	9.6	12
6mm x 5 run	172GP 506	172	140	7.4	5	12

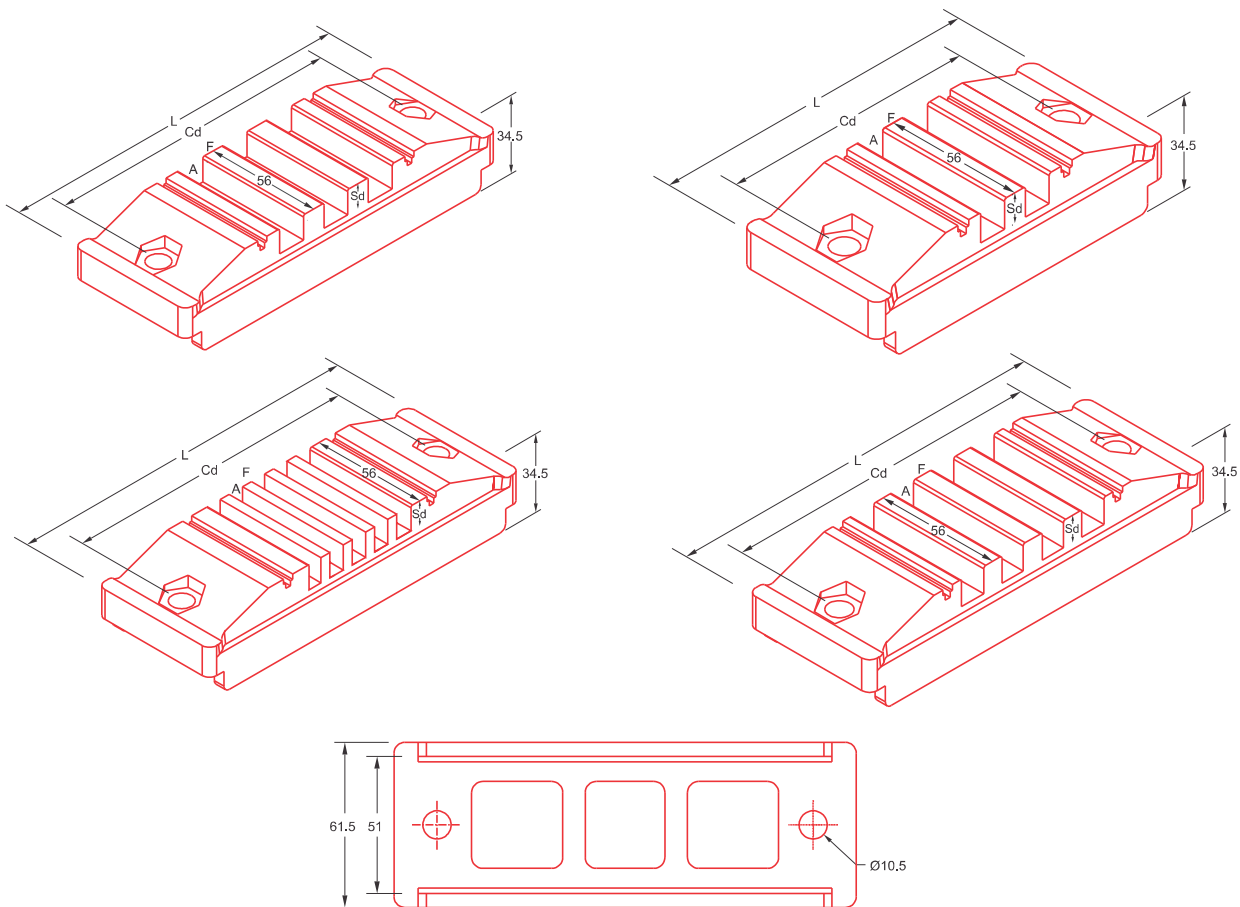

Bottom View of 132 & 172 Series

- Material : Polyamide / Nylon 6,6 (Glass Filled)
- All Dimensions are in MM
- Mounting Detail on Page No. 82
- All Insulators are CE certified
- For technical details of Busbar support & Insulator, please refer POWERMAT TECHNICAL NOTES - 02/18.
- For checking the suitability of a support & insulator for a fault current, please ask for POWERMAT FAULT LEVEL CALCULATOR Software.

Polyamide Series

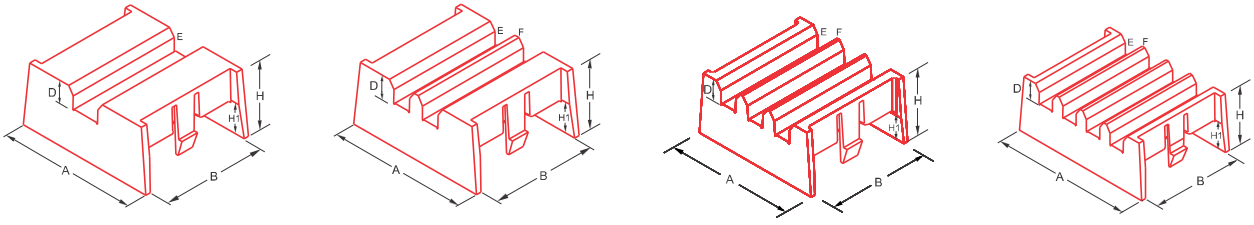

Polyamide Grip Type Supports

Busbar Details	POWERMAT Code	A	B	C	D	E	F	H	H1	Std. Pkg. (Nos.)	Box Wt. (Kg.)
10mm x 1 run	PAGP 110	54	38	20	8	11	-	25	12.5	50	1.450
12mm x 1 run	PAGP 112	54	38	20	8	13.7	-	25	12.5	50	1.425
6mm x 2 run	PAGP 207	54	38	20	8	7	5.8	25	12.5	50	1.350
10mm x 2 run	PAGP 210	54	38	20	8	11	9	25	12.5	50	1.200
6mm x 3 run	PAGP 307	54	38	20	8	7	5.8	25	12.5	50	1.200
6mm x 4 run	PAGP 407	64	38	30	8	7	5.4	25	12.5	50	1.350
5mm x 5 run	PAGP 505	76	41	19,19	8	5.3	4.7	25	12.5	30	1.440
6mm x 5 run	PAGP 507	76	41	19,19	8	6.7	6.3	25	12.5	30	1.572
10mm x 5 run	PAGP 510	118	38	30	8	11.4	9	25	12.5	20	1.460

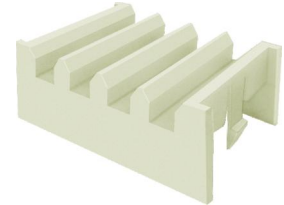

POWERMAT Code	Part Code	A max.	F min.	Std. Pkg. (Nos.)	Box Wt. (Kg.)
10mm x 2 runs	132PAGP210	11	9	50	1.350
12mm x 2 runs	132PAGP212	13.7	11	50	1.200
6mm x 3 runs	132PAGP306	7	5.4	50	1.200
6mm x 4 runs	132PAGP406	7.2	5.2	50	1.350

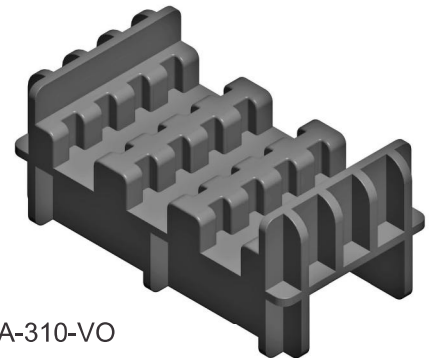
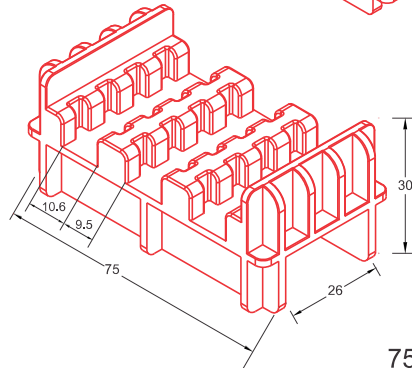
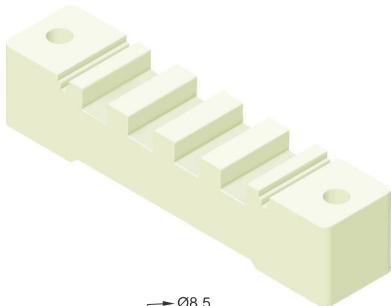
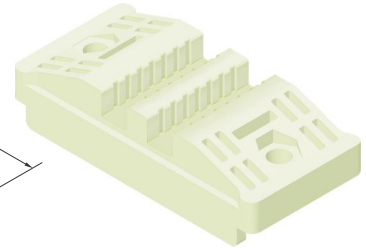
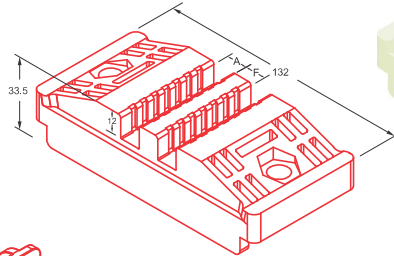

75 PA-310-VO

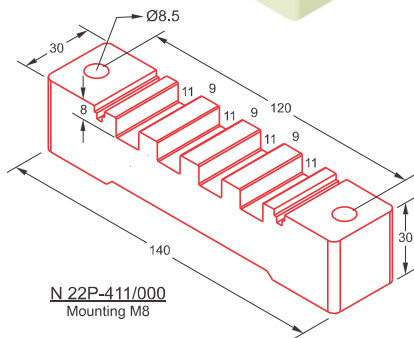

T-Support

POWERMAT Code	H mm	A mm	Std. Pkg. (Nos.)	Box Wt. (Kg.)
PAT - 85	85	52	50	2.800
PAT - 125	125	94	40	2.836

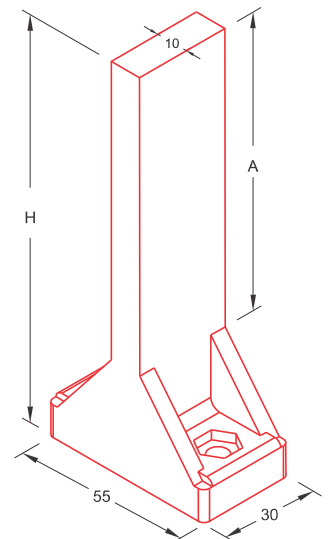
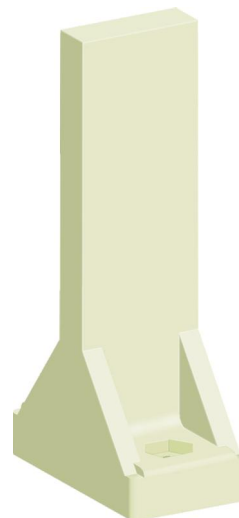

• Material : Polyamide / Nylon 6/6 (17% Glass Filled)
 • All Dimensions are in MM

• Mounting Detail on Page No. 82

• For technical details of Busbar support & Insulator, please refer POWERMAT TECHNICAL NOTES - 02/18.
 • For checking the suitability of a support & insulator for a fault current, please ask for POWERMAT FAULT LEVEL CALCULATOR Software.

Insulator for Vertical / Horizontal Bars

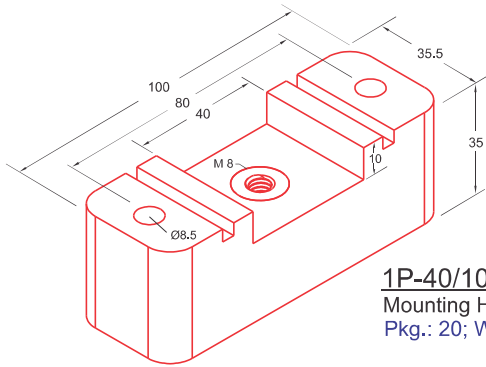
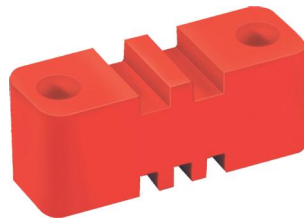
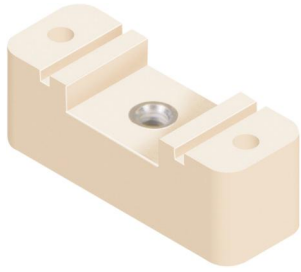

1P-40/100 (M 8)
Mounting Hole Ø8.5
Pkg.: 20; Wt.: 3.500

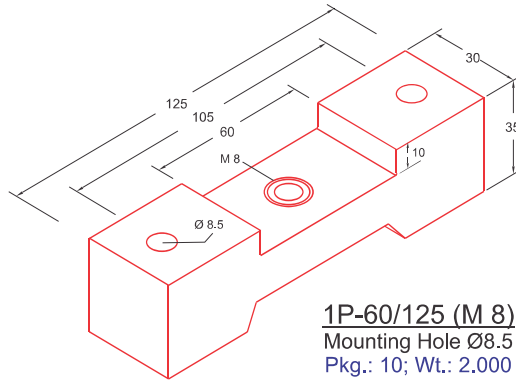

1P-60/125 (M 8)
Mounting Hole Ø8.5
Pkg.: 10; Wt.: 2.000

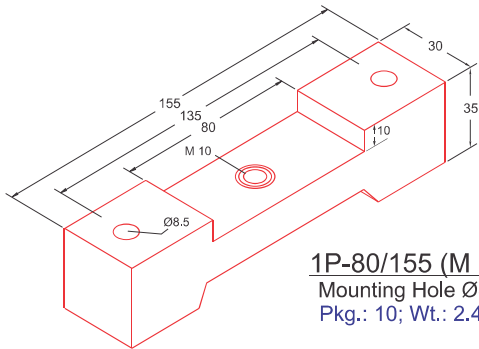

1P-80/155 (M 10)
Mounting Hole Ø8.5
Pkg.: 10; Wt.: 2.400

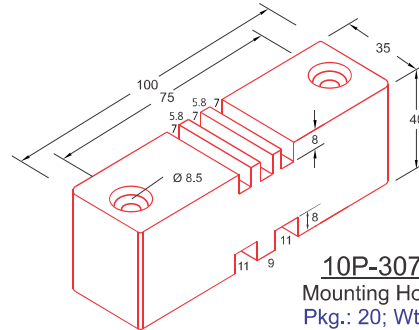

10P-307/211
Mounting Hole Ø8.5
Pkg.: 20; Wt.: 4.200

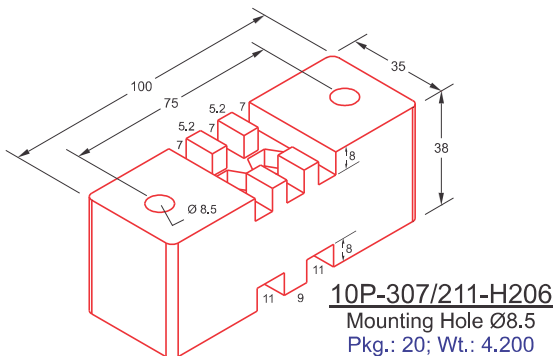

10P-307/211-H206
Mounting Hole Ø8.5
Pkg.: 20; Wt.: 4.200

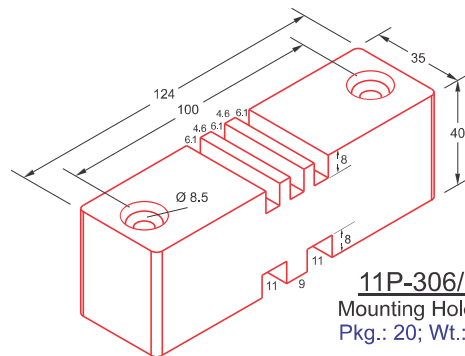

11P-306/211
Mounting Hole Ø8.5
Pkg.: 20; Wt.: 5.700

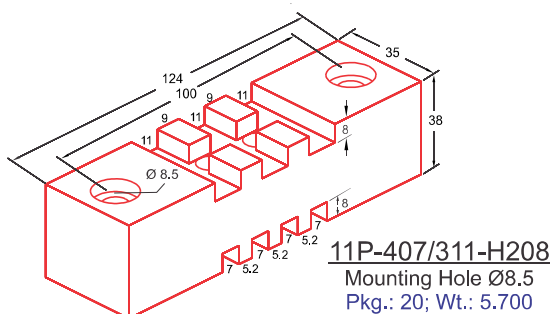

11P-407/311-H208
Mounting Hole Ø8.5
Pkg.: 20; Wt.: 5.700

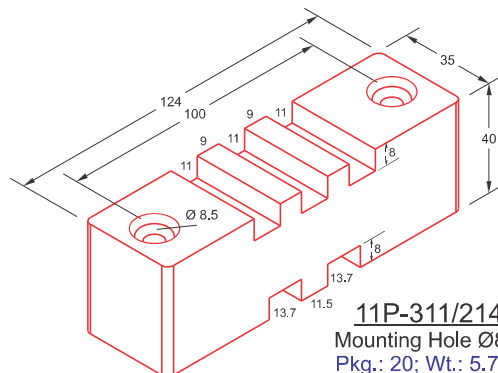

11P-311/214
Mounting Hole Ø8.5
Pkg.: 20; Wt.: 5.700

• Material : SMC (Sheet Moulding Compound) / DMC (Dough Moulding Compound)  UL File No. QEU2.E249670 (Halogen Free)
• All Dimensions are in MM • Mounting Detail on Page No. 83

• All Insulators are  certified

• For technical details of Busbar support & Insulator, please refer POWERMAT TECHNICAL NOTES - 02/18.

• For checking the suitability of a support & insulator for a fault current, please ask for POWERMAT FAULT LEVEL CALCULATOR Software.

Insulator for Vertical / Horizontal Bars

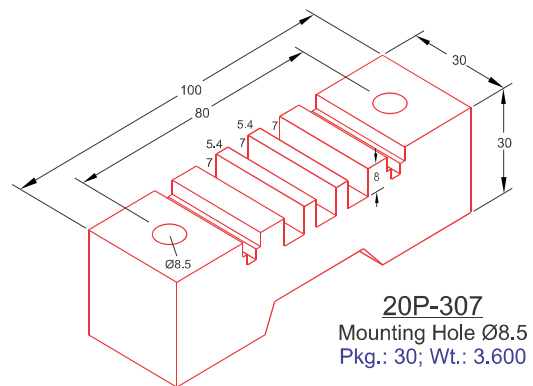
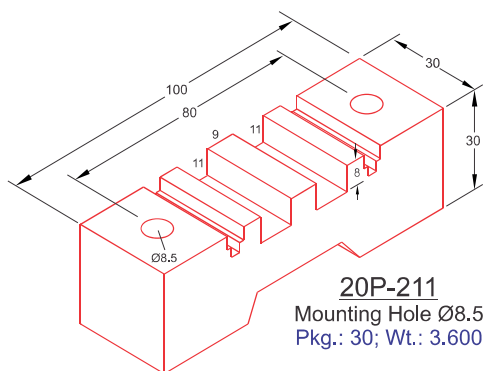
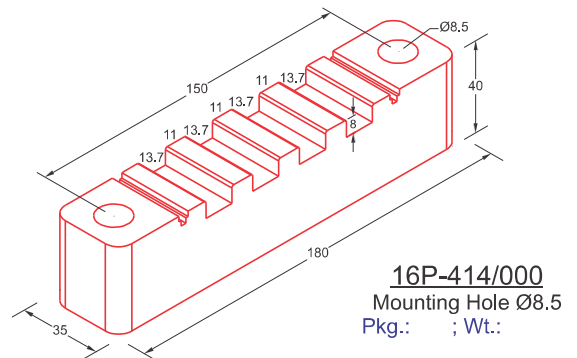
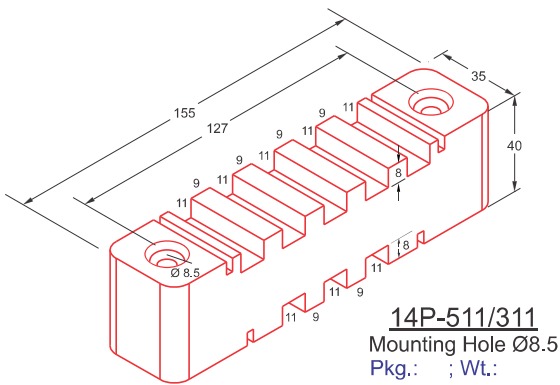
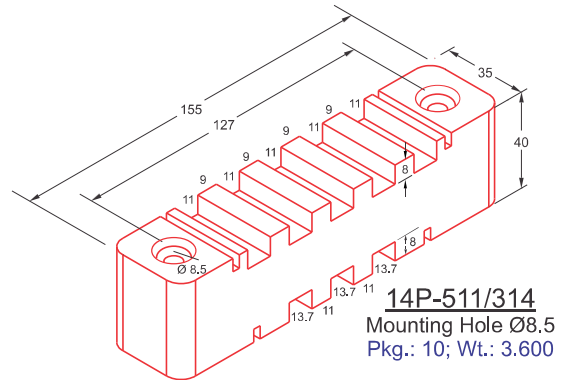
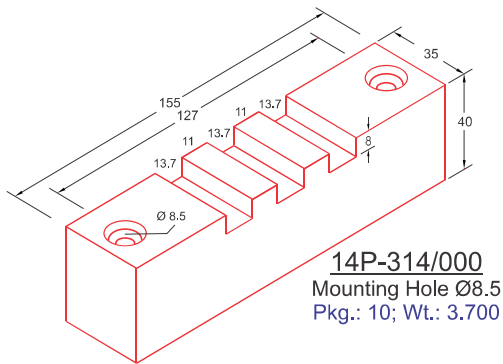
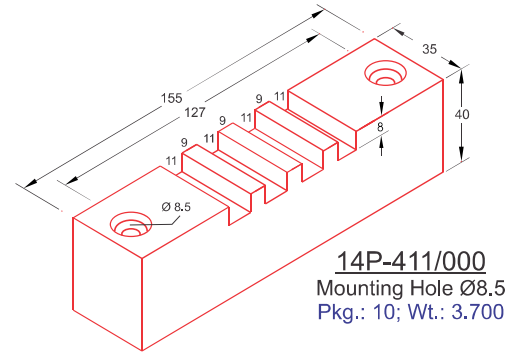
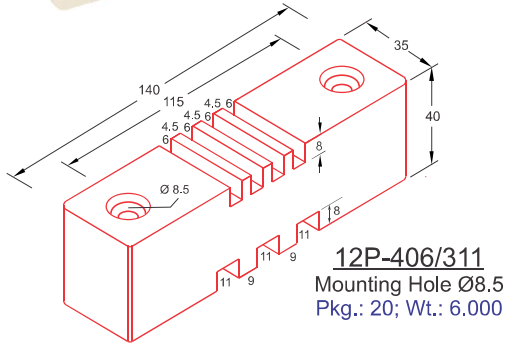
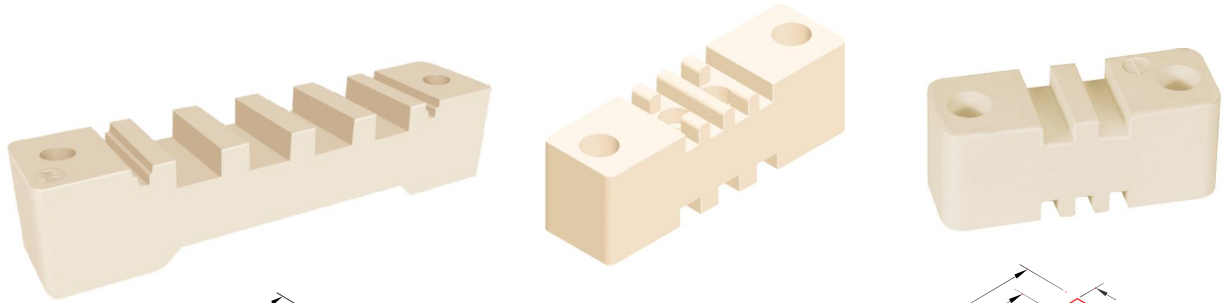

- Material : SMC (Sheet Moulding Compound) / DMC (Dough Moulding Compound) UL File No. QEU2.E249670 (Halogen Free)
- All Dimensions are in MM
- All Insulators are certified
- C-C (Ph)=Centre to Centre Between Phases
- Mounting Detail on Page No. 83
- For technical details of Busbar support & Insulator, please refer POWERMAT TECHNICAL NOTES - 02/18.
- For checking the suitability of a support & insulator for a fault current, please ask for POWERMAT FAULT LEVEL CALCULATOR Software.

Insulator for Vertical / Horizontal Bars

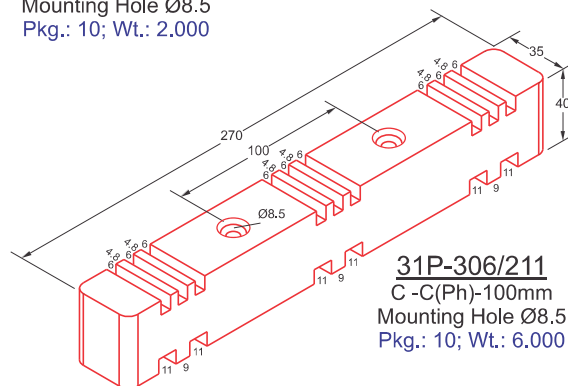
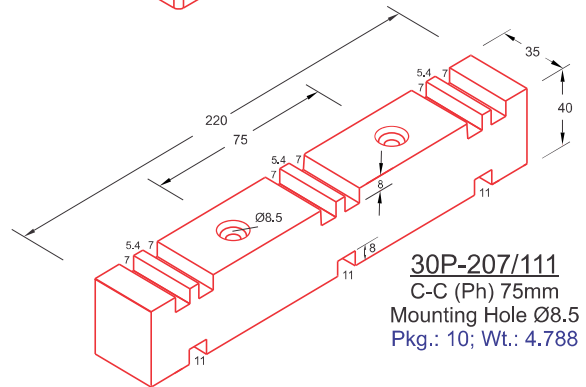
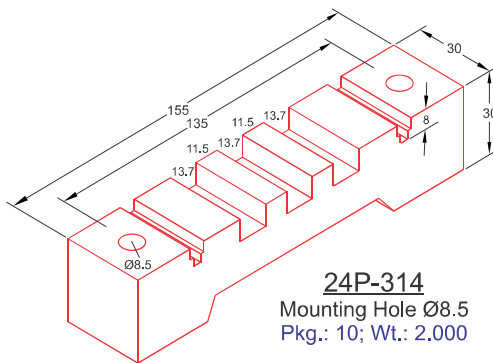
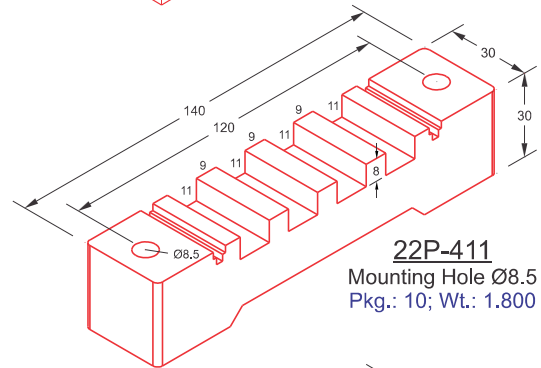
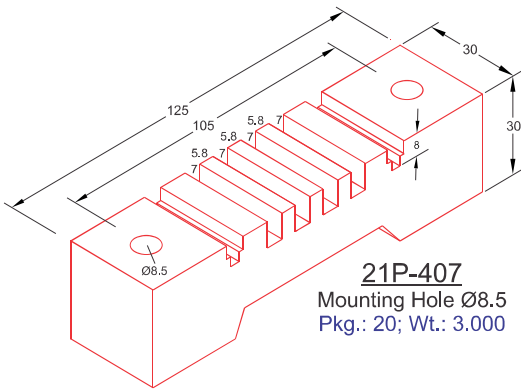
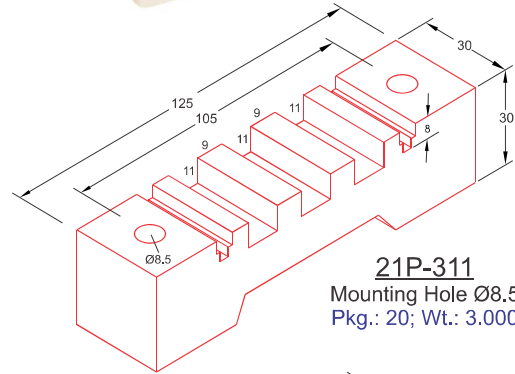
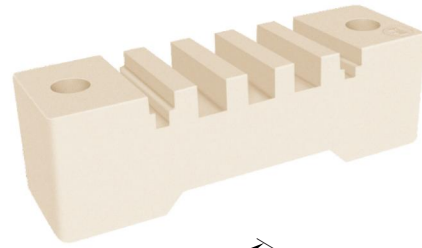
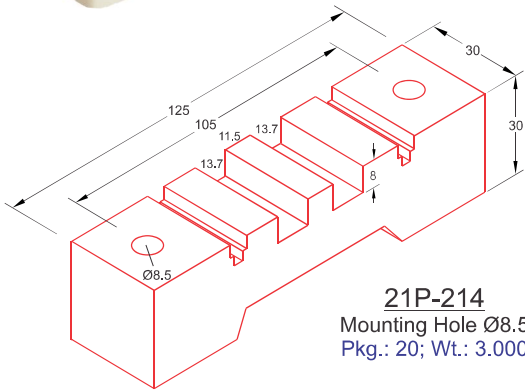
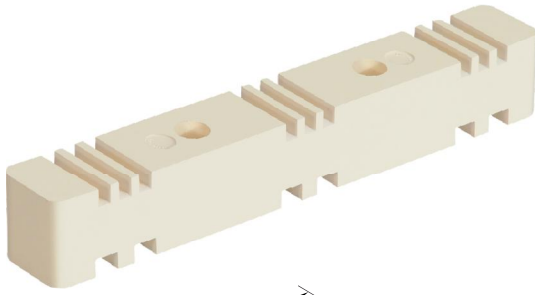

- Material : SMC (Sheet Moulding Compound) / DMC (Dough Moulding Compound) UL File No. QEU2.E249670 (Halogen Free)
- All Dimensions are in MM
- Mounting Detail on Page No. 83
- All Insulators are certified
- For technical details of Busbar support & Insulator, please refer POWERMAT TECHNICAL NOTES - 02/18.
- For checking the suitability of a support & insulator for a fault current, please ask for POWERMAT FAULT LEVEL CALCULATOR Software.

Insulator for Vertical / Horizontal Bars

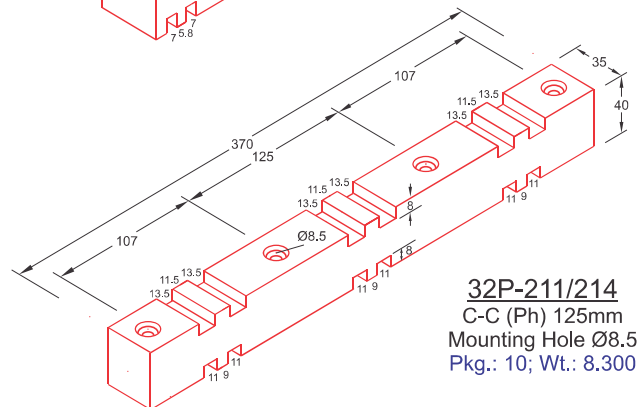
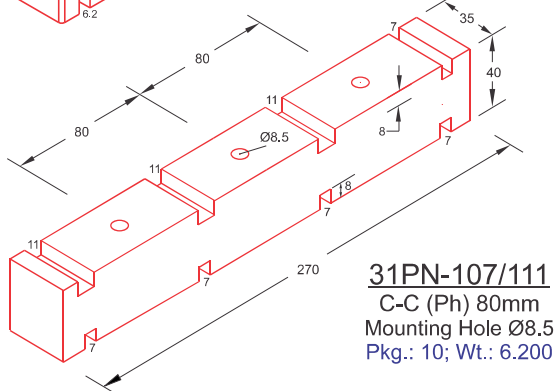
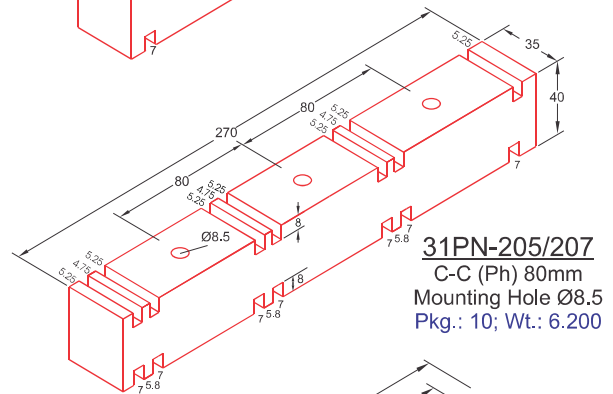
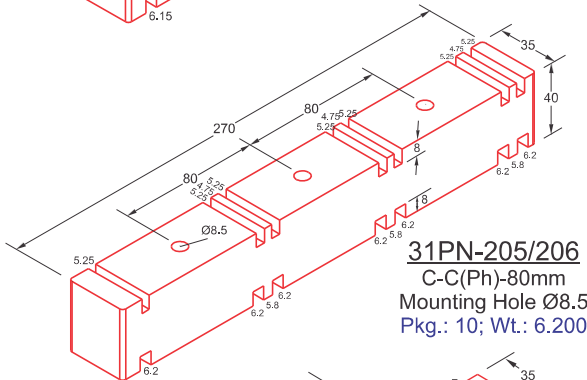
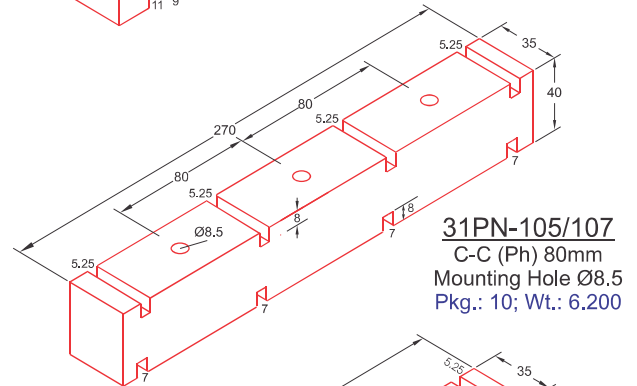
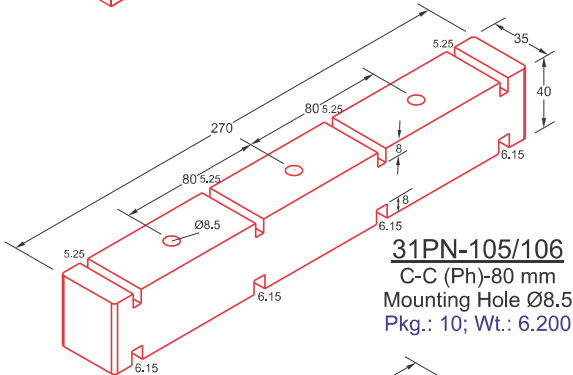
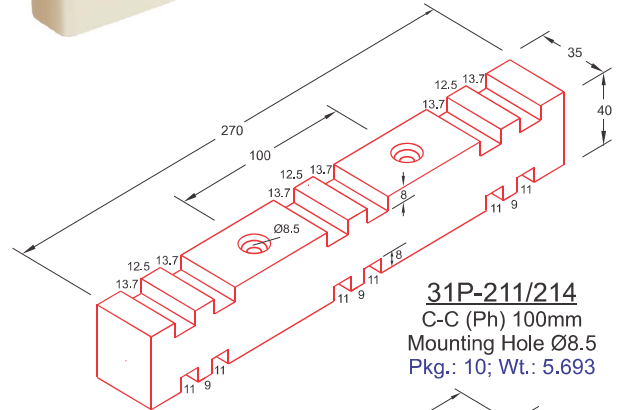
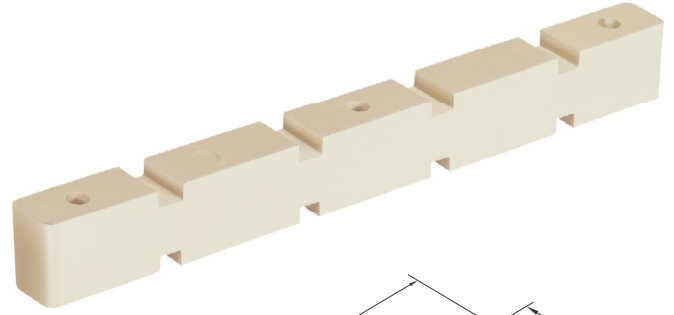
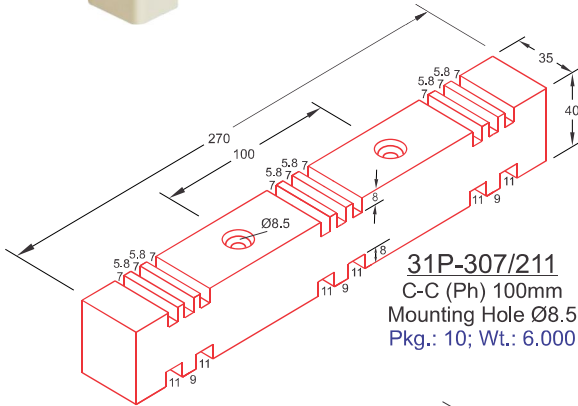
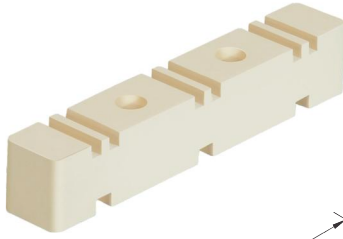

- Material : SMC (Sheet Moulding Compound) / DMC (Dough Moulding Compound) UL File No. QEUY2.E249670 (Halogen Free)
- All Dimensions are in MM
- C-C (Ph)=Centre to Centre Between Phases
- Mounting Detail on Page No. 83
- All Insulators are certified
- For technical details of Busbar support & Insulator, please refer POWERMAT TECHNICAL NOTES - 02/18.
- For checking the suitability of a support & insulator for a fault current, please ask for POWERMAT FAULT LEVEL CALCULATOR Software.

Insulator for Vertical / Horizontal Bars

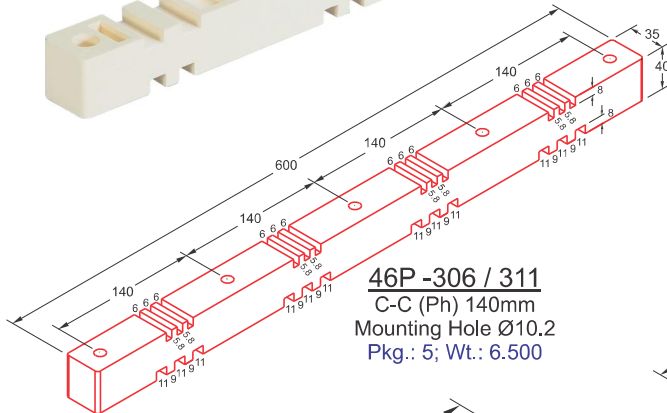
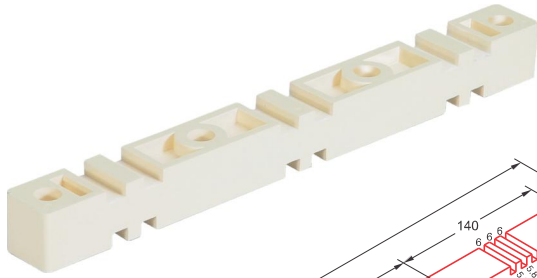

46P-306 / 311
C-C (Ph) 140mm
Mounting Hole Ø10.2
Pkg.: 5; Wt.: 6.500

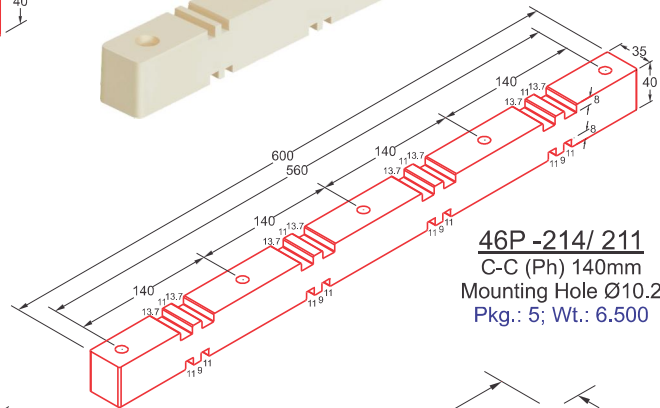
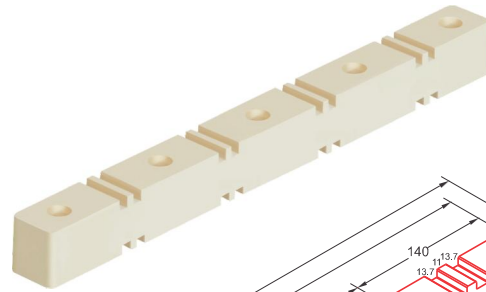

46P-214/ 211
C-C (Ph) 140mm
Mounting Hole Ø10.2
Pkg.: 5; Wt.: 6.500

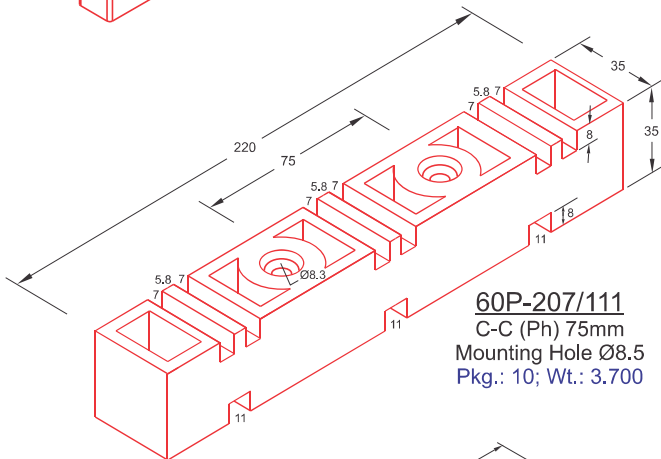

60P-207/111
C-C (Ph) 75mm
Mounting Hole Ø8.5
Pkg.: 10; Wt.: 3.700

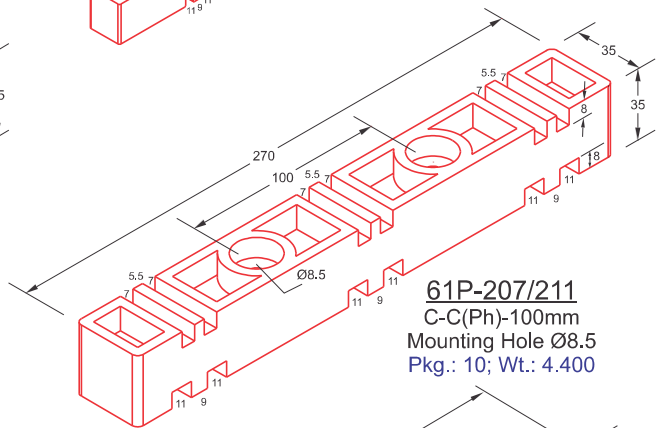

61P-207/211
C-C(Ph)-100mm
Mounting Hole Ø8.5
Pkg.: 10; Wt.: 4.400

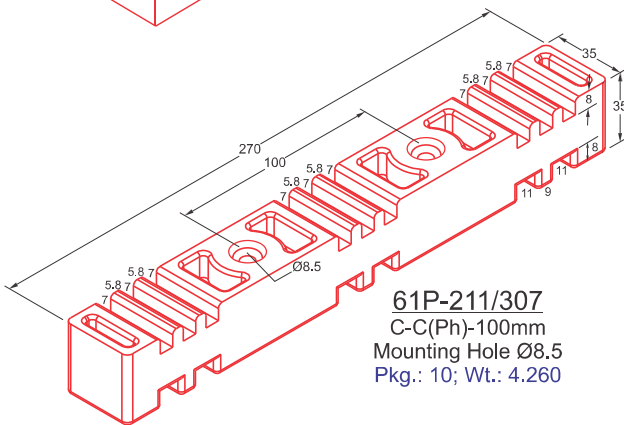

61P-211/307
C-C(Ph)-100mm
Mounting Hole Ø8.5
Pkg.: 10; Wt.: 4.260

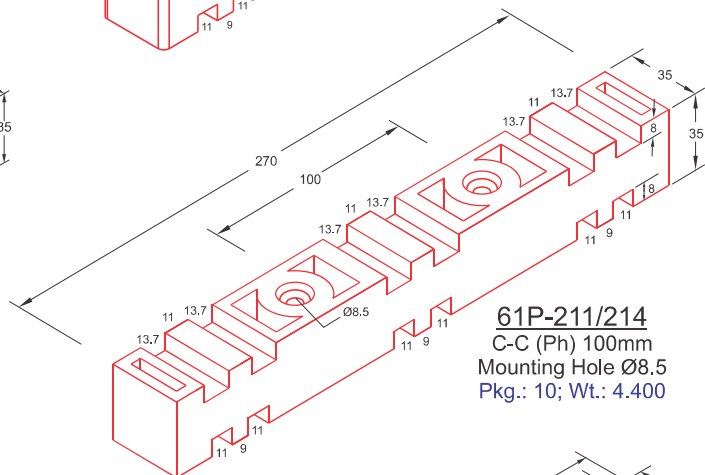

61P-211/214
C-C (Ph) 100mm
Mounting Hole Ø8.5
Pkg.: 10; Wt.: 4.400

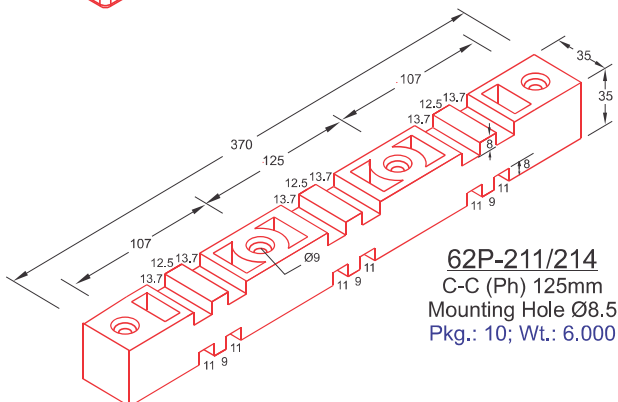

62P-211/214
C-C (Ph) 125mm
Mounting Hole Ø8.5
Pkg.: 10; Wt.: 6.000

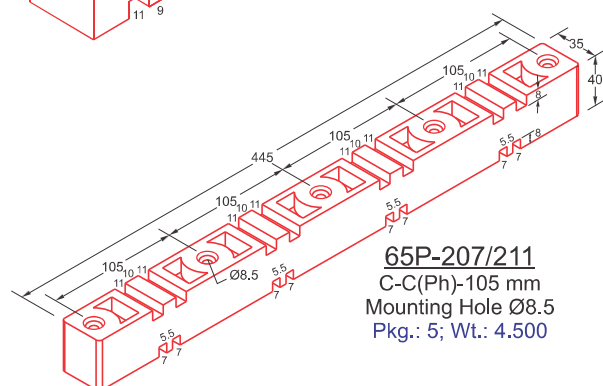

65P-207/211
C-C(Ph)-105 mm
Mounting Hole Ø8.5
Pkg.: 5; Wt.: 4.500

- Material : SMC (Sheet Moulding Compound) / DMC (Dough Moulding Compound) UL File No. QEU2.E249670 (Halogen Free)
- All Dimensions are in MM
- C-C (Ph)=Centre to Centre Between Phases
- Mounting Detail on Page No. 83
- All Insulators are certified
- For technical details of Busbar support & Insulator, please refer POWERMAT TECHNICAL NOTES - 02/18.
- For checking the suitability of a support & insulator for a fault current, please ask for POWERMAT FAULT LEVEL CALCULATOR Software.

Insulator for Vertical / Horizontal Bars

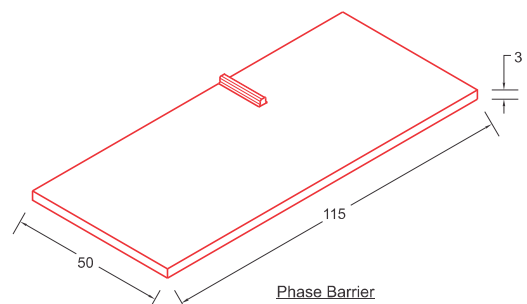
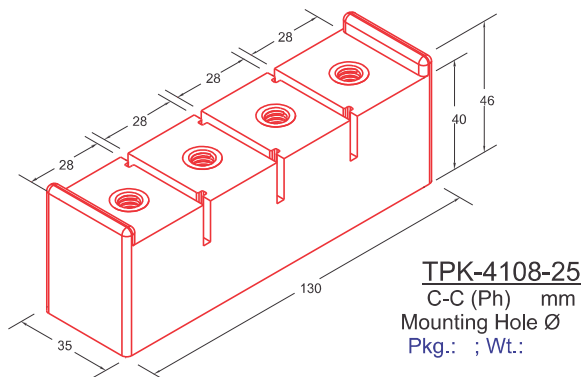
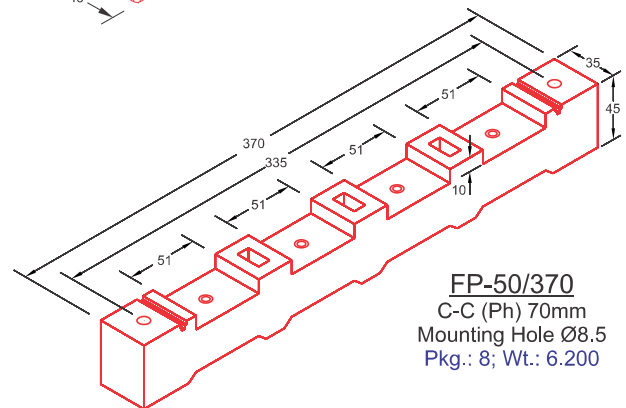
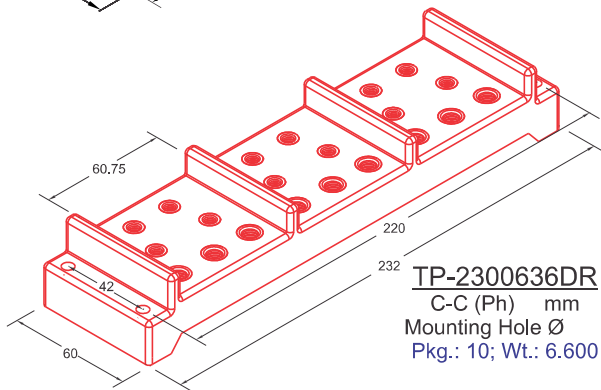
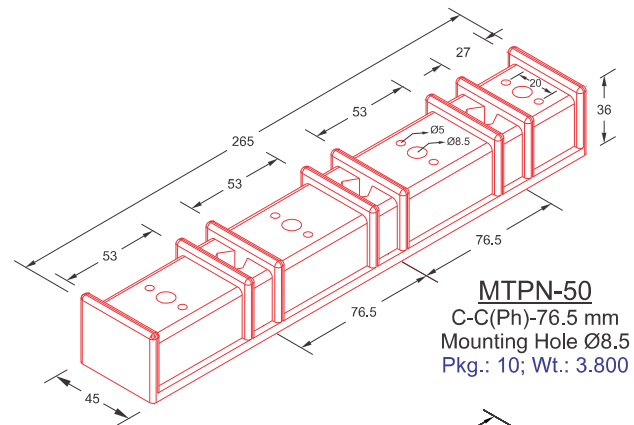
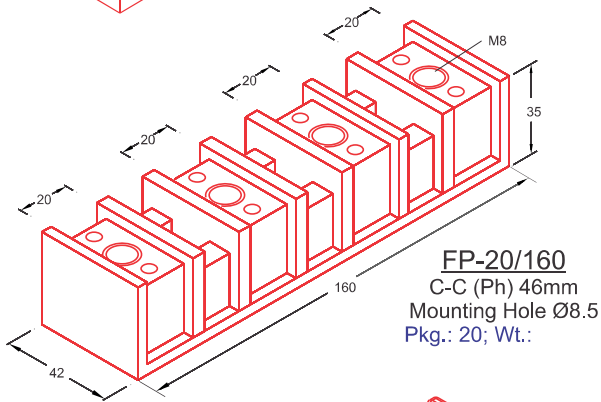
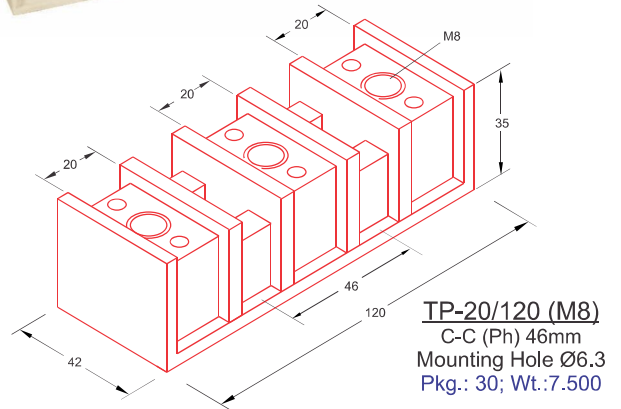
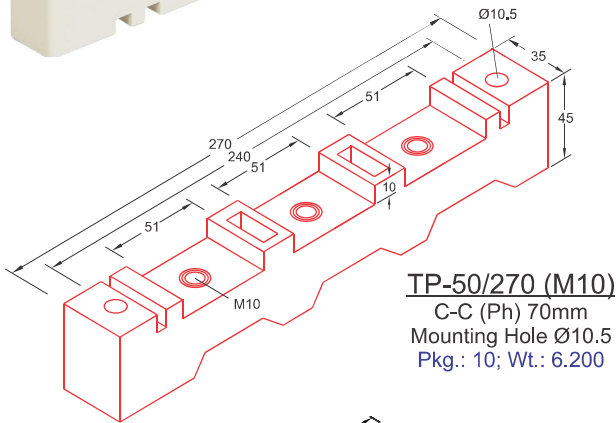

- Material : SMC (Sheet Moulding Compound) / DMC (Dough Moulding Compound)  UL File No. QEU2.E249670 (Halogen Free)
- All Dimensions are in MM
- C-C (Ph)=Centre to Centre Between Phases
- Mounting Detail on Page No. 83
- All Insulators are  certified

- For technical details of Busbar support & Insulator, please refer POWERMAT TECHNICAL NOTES - 02/18.
- For checking the suitability of a support & insulator for a fault current, please ask for POWERMAT FAULT LEVEL CALCULATOR Software.

Adjustable Busbar Support

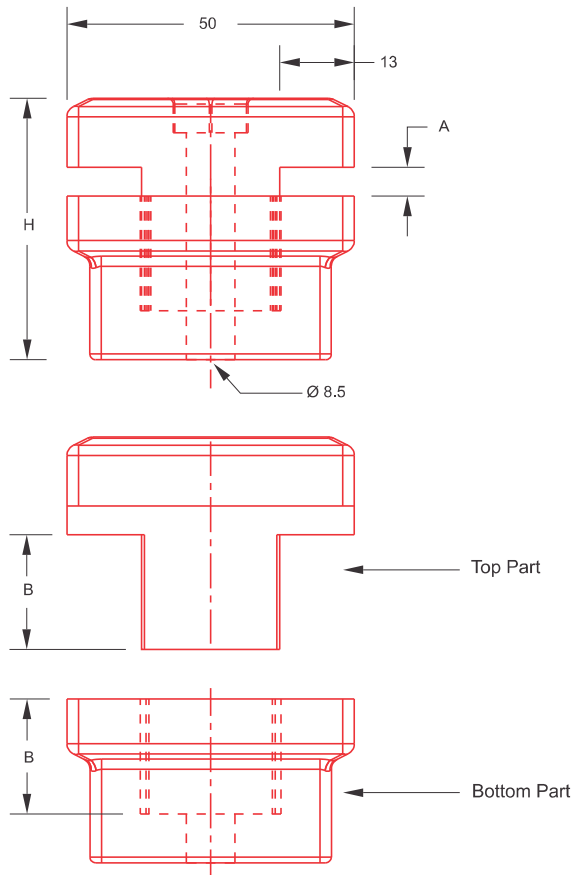
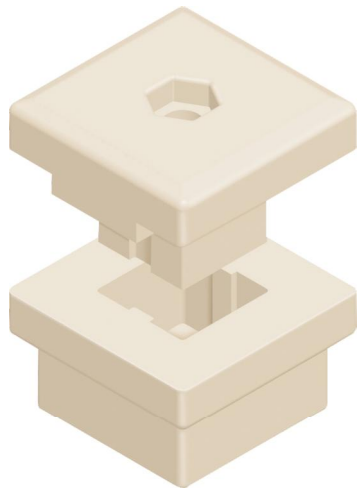

Part No.	Busbar	H* (mm)	A* (mm)	B (mm)	Std. Pkg. (Nos.)	Box Wt. (Kg.)
HB 10/50	6mm x 1run	46.5	6	20	25	3.750
	6mm x 2run	59.5	19	20	25	4.800
	10mm x 1run	50.5	10	20	25	4.000
	12mm x 1run	52.5	12	20	25	4.300
HB 12/50	6mm x 3run	86.0	31	29	25	6.900
	10mm x 2run	86.0	31	29	25	6.900
	12mm x 1run	67.0	12	29	25	5.400

* H & A dimensions are variables
* Mounting Hole - Ø8.5

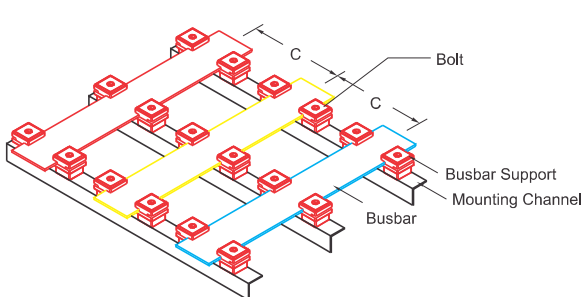

Single Busbar Fixing Arrangement
C-C = Centre to Centre Phase distance in mm

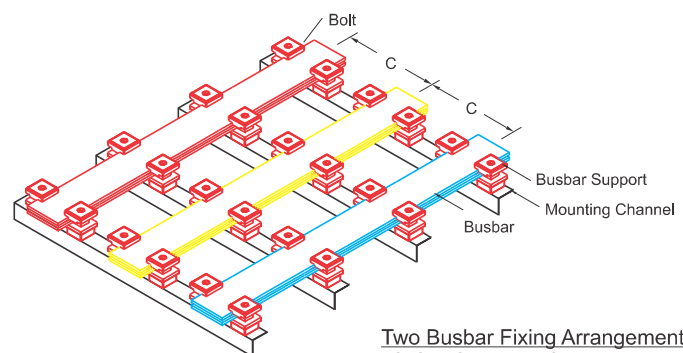



Two Busbar Fixing Arrangement
C-C = Centre to Centre Phase distance in mm

- Material : SMC (Sheet Moulding Compound) / DMC (Dough Moulding Compound) UL File No. QEUY2.E249670 (Halogen Free)
- All Dimensions are in MM
- C-C (Ph)=Centre to Centre Between Phases
- All Insulators are certified
- For technical details of Busbar support & Insulator, please refer POWERMAT TECHNICAL NOTES - 02/18.
- For checking the suitability of a support & insulator for a fault current, please ask for POWERMAT FAULT LEVEL CALCULATOR Software.

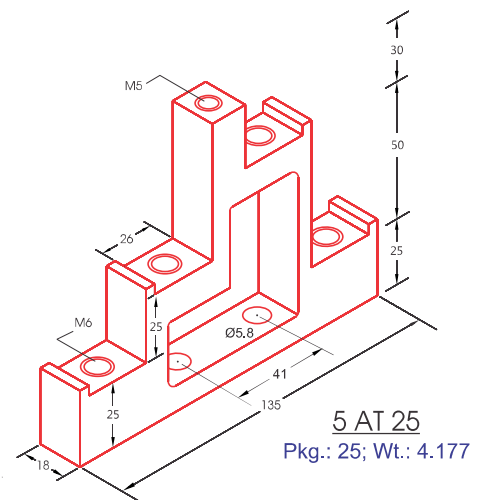
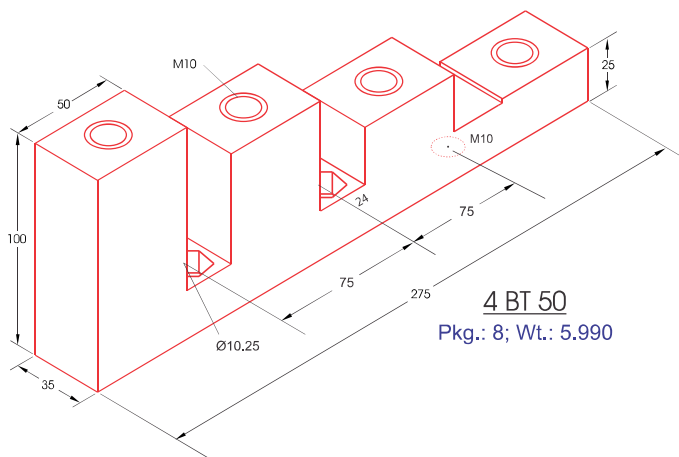
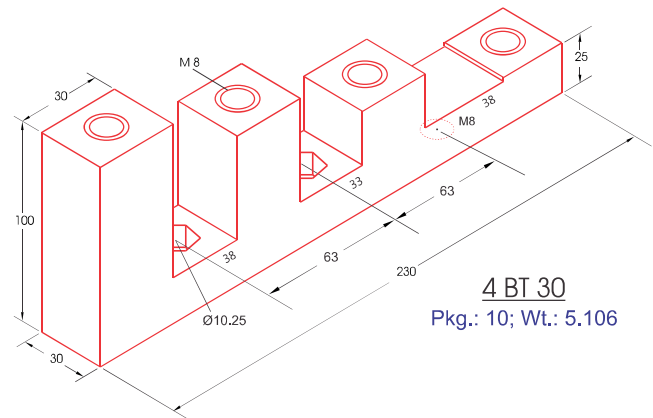
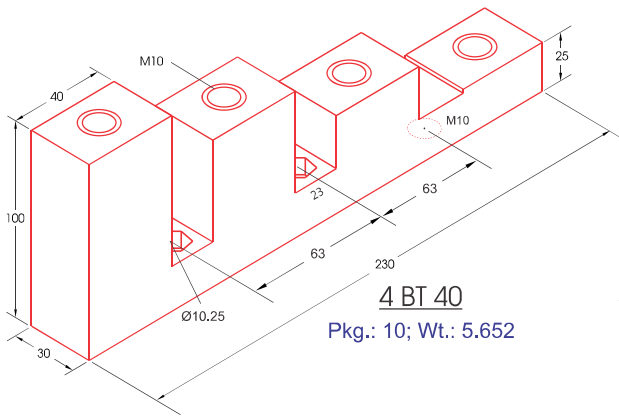
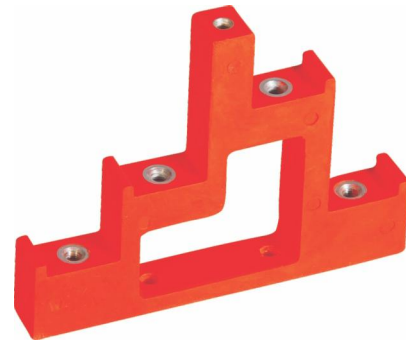
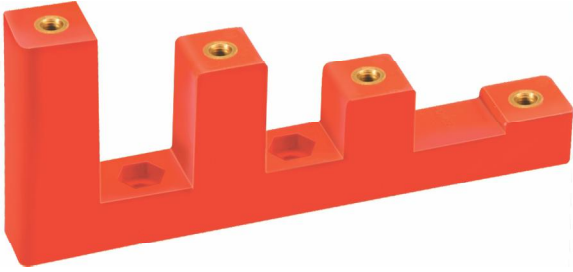
Step Insulators



- Material : DMC (Dough Moulding Compound)  UL File No. QEUY2.E249670 (Halogen Free)
- Insert : Brass / Steel (Zinc Passivated)
- Insert Material detail on page no. 83
- Mounting Detail on Page No. 84
- All Insulators are  certified
- For technical details of Busbar support & Insulator, please refer POWERMAT TECHNICAL NOTES - 02/18.
- For checking the suitability of a support & insulator for a fault current, please ask for POWERMAT FAULT LEVEL CALCULATOR Software.

Insulator for Horizontal Bars

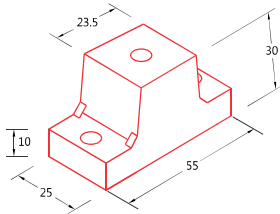
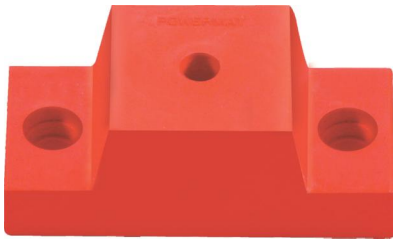

SP-30

Pkg.: 100; Wt.: 3.600

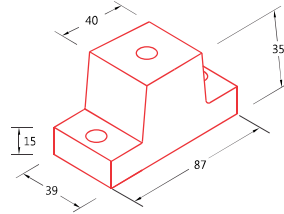

SP-35

Pkg.: 50; Wt.: 4.200

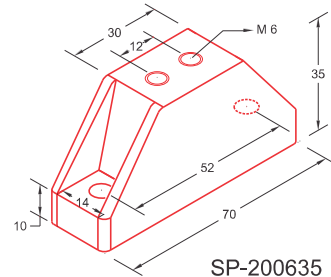

SP-200635

Pkg.: 50; Wt.:

Terminal Supports (Material : DMC)

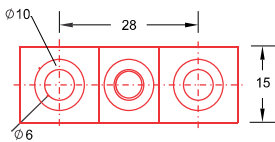

ELS 12 (M5)

Pkg.: 100; Wt.:

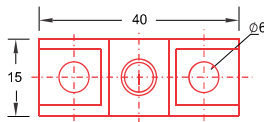

NLS 12 (M5)

Pkg.: 100; Wt.: 1.442

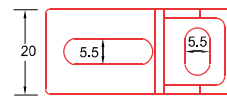

01EBS 25

Pkg.: 100; Wt.: 1.676

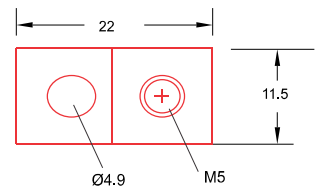

01NLSPS 11 (M5)

Pkg.: 500; Wt.: 2.358

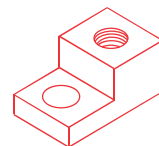
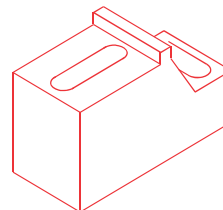
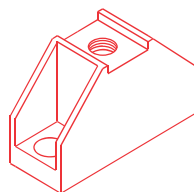
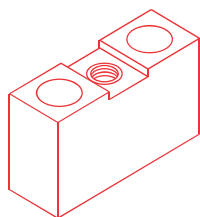
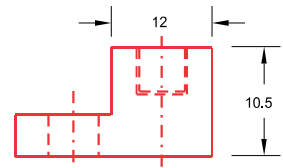
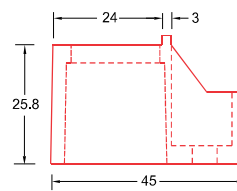
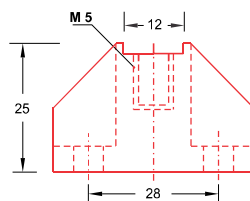
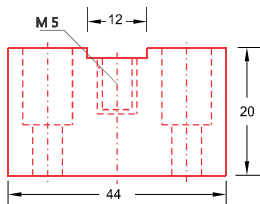

- Material : DMC (Dough Moulding Compound)  UL File No. QEU2.E249670 (Halogen Free)
- Insert : Brass / Steel (Zinc Passivated)
- Insert Material detail on page no. 83
- All Insulators are  certified

- For technical details of Busbar support & Insulator, please refer POWERMAT TECHNICAL NOTES - 02/18.
- For checking the suitability of a support & insulator for a fault current, please ask for POWERMAT FAULT LEVEL CALCULATOR Software.

Neutral Link

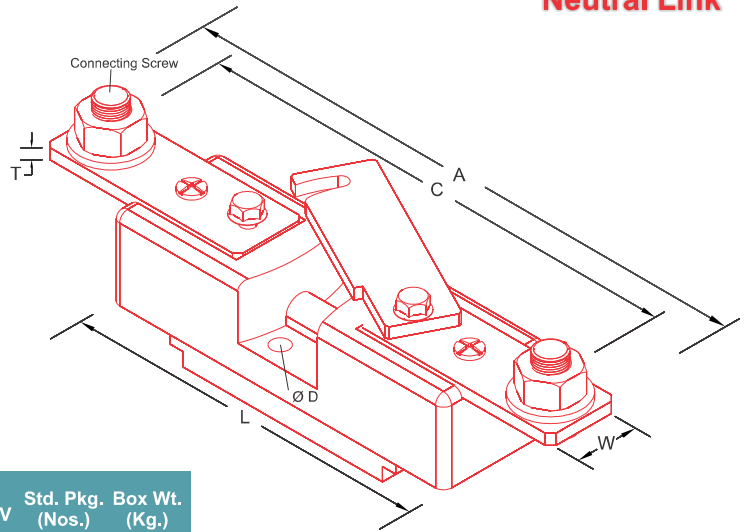
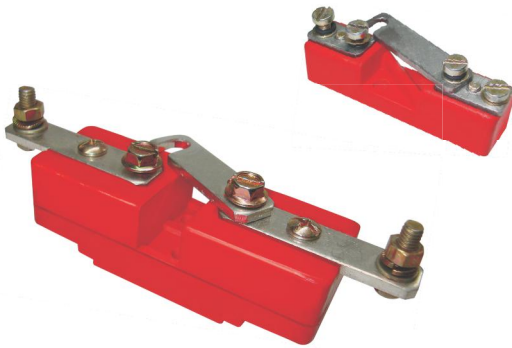

POWERMAT code	A	C	W	L	T	C.Screw	Ø D	H	V	Std. Pkg. (Nos.)	Box Wt. (Kg.)
DTNL 32 Amp	65	57	10	65	2	M 4	5	10.8	6	100	3.500
DTNL 63 Amp	78	67	12	78	2	M 5	5	11	10	50	3.900
DTNL 100 Amp	78	67	12	78	2.5	M 5	5	11	10	50	3.900
DTNL 125 Amp	128	114	16	100	3	M 6	5.5	6	20	20	4.400
DTNL 200 Amp	160	138	20	100	3	M 8	5.5	6	20	20	5.190
DTNL 400 Amp	200	174	25	125	5	M 10	5.5	26	25	5	2.800
DTNL 600 Amp	240	210	38	140	6	M 10	6	24	24	5	5.200

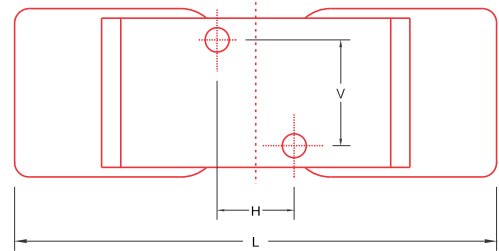

Mounting Dimensions of DTNL Series

Modular Support

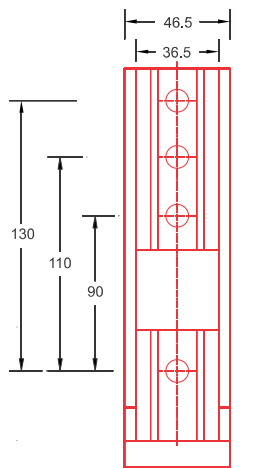
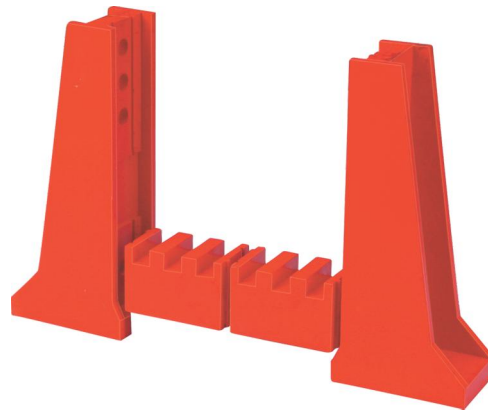

ST 6080100
Pkg.: 10; Wt.: 3.580

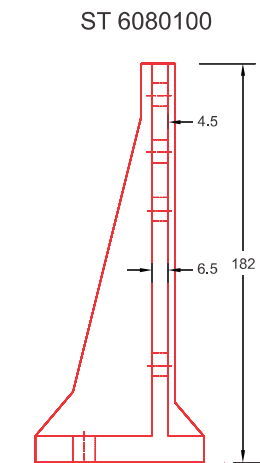

Pkg.: 10; Wt.: 3.580

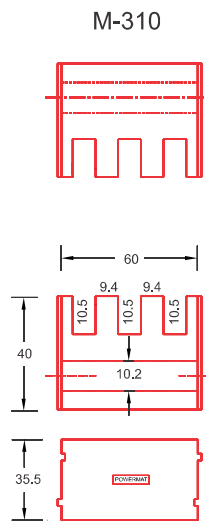

Pkg.: 30; Wt.: 3.744

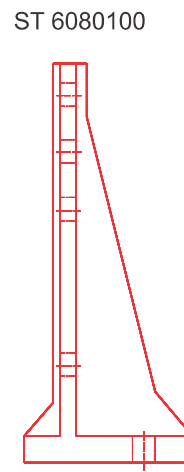

SPM - 310-A

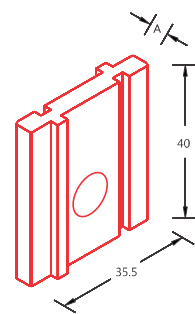

POWERMAT code	A
SPM - 310 - 05	5
SPM - 310 - 10	10
SPM - 310 - 15	15

- Material : DMC (Dough Moulding Compound) UL File No. QEUY2.E249670 (Halogen Free)
- Insert : Brass / Steel (Zinc Passivated)
- Insert Material detail on page no. 83
- Mounting Detail on Page No. 84
- All Insulators are CE certified
- For technical details of Busbar support & Insulator, please refer POWERMAT TECHNICAL NOTES - 02/18.
- For checking the suitability of a support & insulator for a fault current, please ask for POWERMAT FAULT LEVEL CALCULATOR Software.

Three Phase Connector

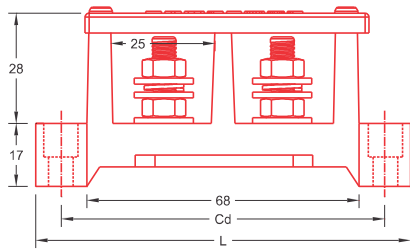

2 - Way Connector

POWERMAT code	Overall Length L	Dimension Distance Between Holes Cd	No.of Connectors	Bolt Size	Std. Pkg. (Nos.)	Box Wt. (Kg.)
TB 2106	95	82	2	M 6 x 22 mm	40	4.200

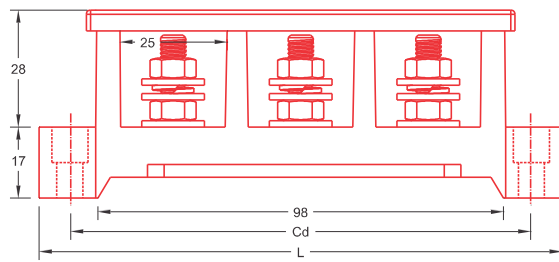

3 - Way Connector

POWERMAT code	Overall Length L	Dimension Distance Between Holes Cd	No.of Connectors	Bolt Size	Std. Pkg. (Nos.)	Box Wt. (Kg.)
TB 3106	125	111	3	M 6 x 22 mm	25	3.700

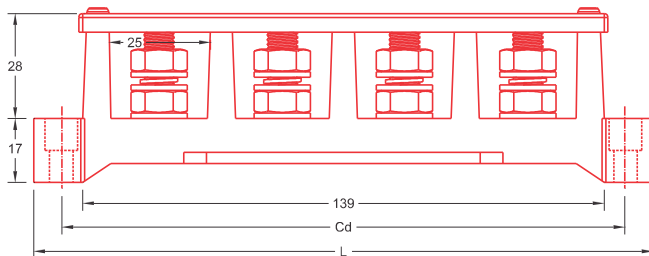

4 - Way Connector

POWERMAT code	Overall Length L	Dimension Distance Between Holes Cd	No.of Connectors	Bolt Size	Std. Pkg. (Nos.)	Box Wt. (Kg.)
TB 4106	165	150	4	M6 x 22mm	20	4.200
TB 4108	165	150	4	M8 x 22mm	20	5.300
TB 4210	225	195	4	M10 x 22mm	10	4.900

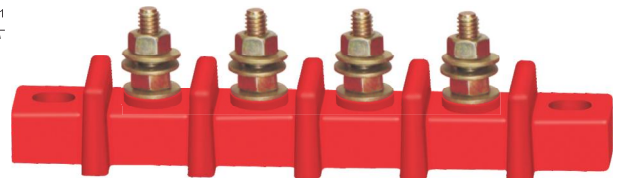
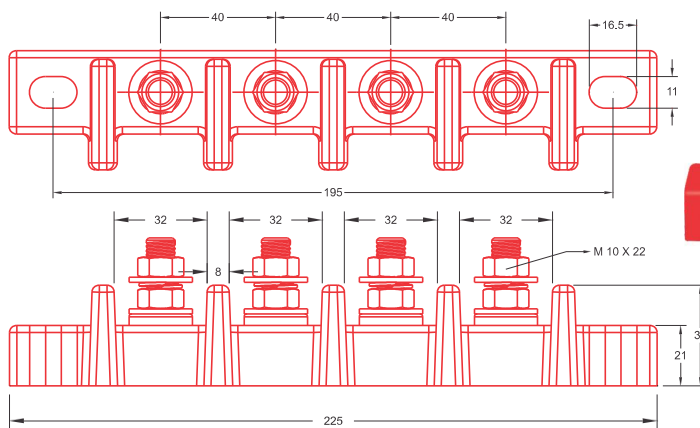

- Material : DMC (Dough Moulding Compound) UL File No. QEUJ2.E249670 (Halogen Free)
- All Dimensions are in MM
- Stud Insert : Brass
- Insert Material detail on page no. 83

Locks for Panel Board

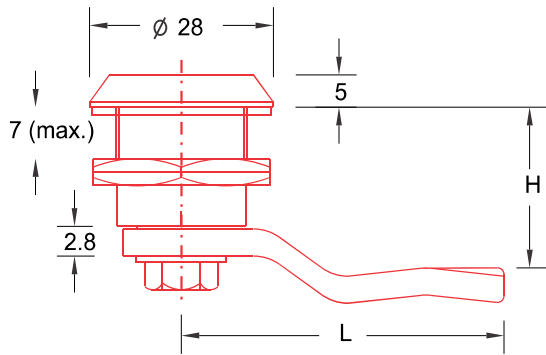

Point Head

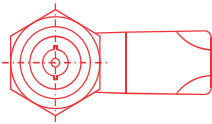

POWERMAT Code	Dimension		Std. Pkg. (Nos.)	Box Wt. (Kg.)
	H	L		
101-2L25S	25	35	50	3.400
101-225L	25	45	50	3.800
101-245S	45	35	50	4.000
101-245L	45	45	50	4.400
101-250S	50	35	40	3.130
101-250L	50	45	40	3.530
101-255S	55	35	40	3.800
101-255L	55	45	40	4.200

Square Head

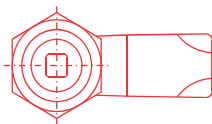

POWERMAT Code	Dimension		Std. Pkg. (Nos.)	Box Wt. (Kg.)
	H	L		
101-425S	25	35	50	3.400
101-425L	25	45	50	3.800
101-445S	45	35	50	4.000
101-445L	45	45	50	4.400
101-450S	50	35	40	3.200
101-450L	50	45	40	3.600
101-455S	55	35	40	3.650
101-455L	55	45	40	4.050

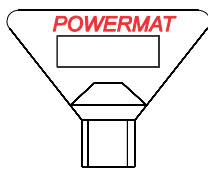

Key



101 K2



101 K3



101 K4



Screw Driver Head

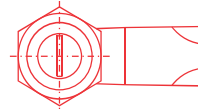

POWERMAT Code	Dimension		Std. Pkg. (Nos.)	Box Wt. (Kg.)
	H	L		
101-125S	25	35	50	3.400
101-125L	25	45	50	3.800
101-145S	45	35	50	4.000
101-145L	45	45	50	4.400
101-150S	50	35	40	3.200
101-150L	50	45	40	3.600
101-155S	55	35	40	4.050
101-155L	55	45	40	4.850
101-130L	30	45	50	3.200

Triangle Head

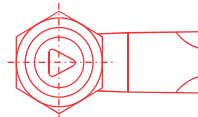

POWERMAT Code	Dimension		Std. Pkg. (Nos.)	Box Wt. (Kg.)
	H	L		
101-325S	25	35	50	3.400
101-325L	25	45	50	3.800
101-345S	45	35	50	4.000
101-325L	45	45	50	4.400
101-350S	50	35	40	3.200
101-350L	50	45	40	3.600
101-355S	55	35	40	3.650
101-355L	55	45	40	4.050

Key Head

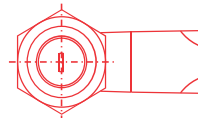

POWERMAT Code	Dimension		Std. Pkg. (Nos.)	Box Wt. (Kg.)
	H	L		
101-KL25S	25	35	50	3.400
101-KL25L	25	45	50	3.800
101-KL45S	45	35	50	4.000
101-KL45L	45	45	50	4.400
101-KL50S	50	35	40	3.200
101-KL50L	50	45	40	3.600
101-KL55S	55	35	40	3.650
101-KL55L	55	45	40	4.050

Polyamide Locks for Panel Board

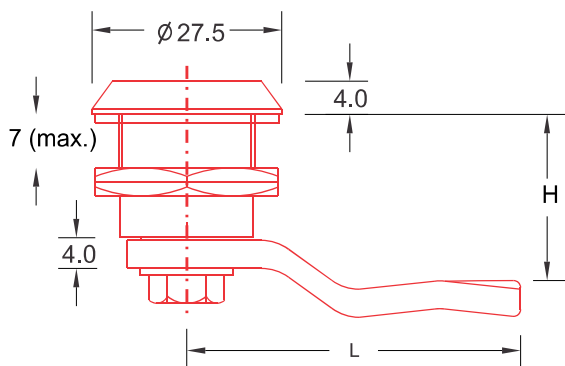

Screw Driver Head

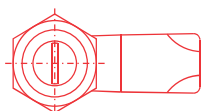

Point Head

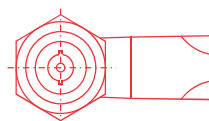

POWERMAT Code	Dimension		Std. Pkg. (Nos.)	Box Wt. (Kg.)
	H	L		
PA 101-12045	20	45	100	1.800
PA 101-12545	25	45	100	1.800
PA 101-13045	30	45	100	1.900
PA 101-13545	35	45	100	1.900
PA 101-14045	40	45	100	2.000
PA 101-14545	45	45	100	2.000
PA 101-15045	50	45	40	0.820
PA 101-15545	55	45	40	0.820

POWERMAT Code	Dimension		Std. Pkg. (Nos.)	Box Wt. (Kg.)
	H	L		
PA 101-22045	20	45	100	1.800
PA 101-22545	25	45	100	1.800
PA 101-23045	30	45	100	1.900
PA 101-23545	35	45	100	1.900
PA 101-24045	40	45	100	2.000
PA 101-24545	45	45	100	2.000
PA 101-25045	50	45	40	0.800
PA 101-25545	55	45	40	0.820

Triangle Head

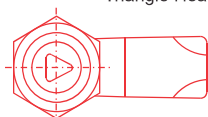

Square Head

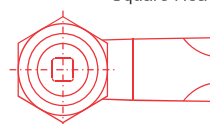

POWERMAT Code	Dimension		Std. Pkg. (Nos.)	Box Wt. (Kg.)
	H	L		
PA 101-32045	20	45	100	1.800
PA 101-32545	25	45	100	1.800
PA 101-33045	30	45	100	1.900
PA 101-33545	35	45	100	1.900
PA 101-34045	40	45	100	2.000
PA 101-34545	45	45	100	2.000
PA 101-35045	50	45	40	0.820
PA 101-35545	55	45	40	0.820

POWERMAT Code	Dimension		Std. Pkg. (Nos.)	Box Wt. (Kg.)
	H	L		
PA 101-42045	20	45	100	1.800
PA 101-42545	25	45	100	1.800
PA 101-43045	30	45	100	1.900
PA 101-43545	35	45	100	1.900
PA 101-44045	40	45	100	2.000
PA 101-44545	45	45	100	2.000
PA 101-45045	50	45	40	0.800
PA 101-45545	55	45	40	0.820



Key



101 K2 101 K3 101 K4

• All Dimensions are in MM

POWERMAT

FRP / Epoxy Pultruded Sections



RODS

POWERMAT code	Ø Dia (mm)
PROD 006	6
PROD 007	7
PROD 008	8
PROD 010	10
PROD 012	12
PROD 016	16
PROD 020	20
PROD 025	25

** Length 1 meter or can be any as per requirement.
Material:- Polyester/Epoxy.



TUBES

POWERMAT code	Ø Dia (mm)	
	I.D	O.D
PT 0610	6.5	10
PT 0812	8.5	12
PT 1016	10.5	16
PT 1220	12.5	20
PT 2025	19.0	25

** Length 1 meter or can be any as per requirement.
Material:- Polyester/Epoxy.

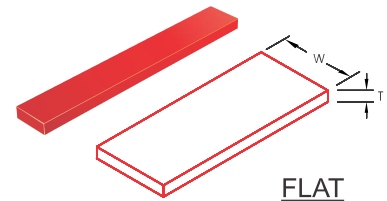

FLAT

POWERMAT code	Dimension (mm)	
	W	T
PF 0425	25	04
PF 1225	25	12
PF 1030	30	10
PF 1040	40	10
PF 1050	50	10
PF 2060	60	20

** Length 1 meter or can be any as per requirement.
Material:- Polyester/Epoxy.

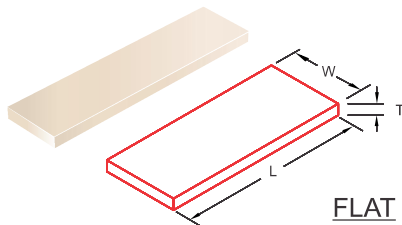

FLAT

POWERMAT code	Dimension (mm)		
	W	T	L
SF 205035	50	20	350
SF 403560	35	40	600
SF 305078	50	30	780

** Material SMC

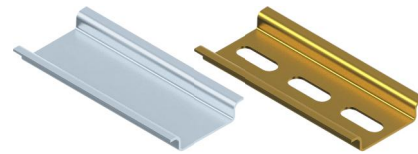

DINRAIL
Plane & Slotted

DIN 357508	- 35 x 7.5 x 0.8mm
DIN 357510	- 35 x 7.5 x 1.0mm
DIN 351515	- 35 x 15 x 1.5mm
DIN 32150915	- 32 x 15 x 1.5mm

DIN 357508 S	- 35 x 7.5 x 0.8mm
DIN 357510 S	- 35 x 7.5 x 1.0mm
DIN 351515 S	- 35 x 15 x 1.5mm
DIN 32150915 S	- 32 x 15 x 1.5mm

* Standard length 1 metre or can be any as per requirement
Material CRGO Sheet, Zinc Passivated

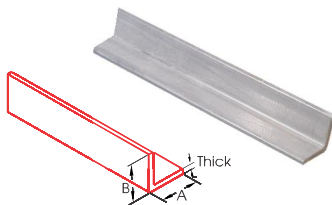

ANGLES

POWERMAT code	Dimension (mm)		
	A	B	Thk.
PA 353505	35	35	5
PA 505006	50	50	6
PA 755010	75	50	10

** Length 1 meter or can be any as per requirement.
Material:- Polyester.

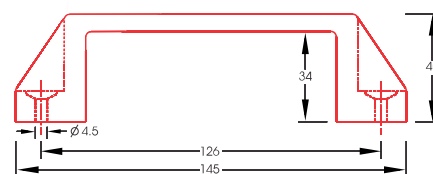

ABS HANDLE

AH 40145

Pkg.: 200 Pcs.; Wt.: 9.900 Kg.

• Material : SMC (Sheet Moulding Compound) UL File No. QEU2.E249670 (Halogen Free)

• All Dimensions are in MM

Document Holder

POWERMAT code	Dimension						Std. Pkg. (Nos.)	Box Wt. (Kg.)
	A	B	C	D	E	F		
DHA5	190	185	175	143	160	20	5	0.600
DHA4	280	234	266	150	245	30	4	0.820

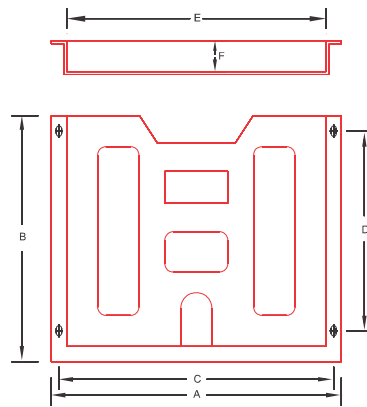

Air Vent Cover

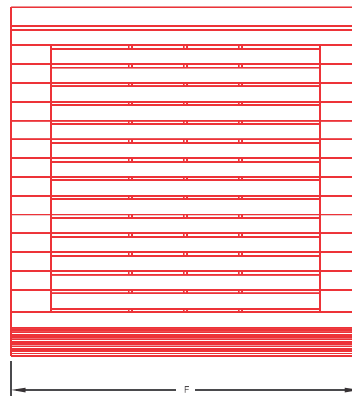
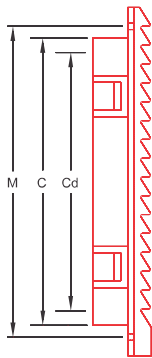

POWERMAT code	Dimension M	Cut off Size C	Overall Size F	Fan Mounting Cd	Fan Size Inch	Std. Pkg. (Nos.)	Box Wt. (Kg.)
AV 130	130 x 130mm	123 x 123mm	148 x 148mm	105 x 105mm	4	2	0.288
AV 184	184 x 184mm	177 x 177mm	214 x 214mm	155 x 155mm	6	2	0.615
AV 230	236 x 236mm	224 x 224mm	260 x 260mm	204 x 204mm	8	1	0.474
AV 184 DM-604	184 x 184mm	177 x 177mm	214 x 214mm	105 x 105mm	4	1	0.405
AV 230 DM-806	236 x 236mm	224 x 224mm	260 x 260mm	155 x 155mm	6	1	0.908

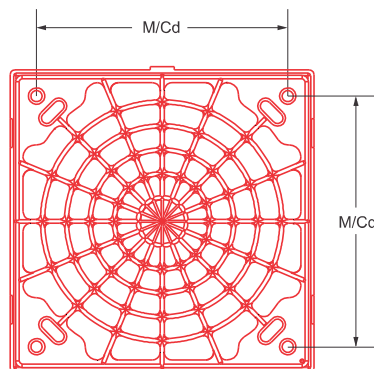
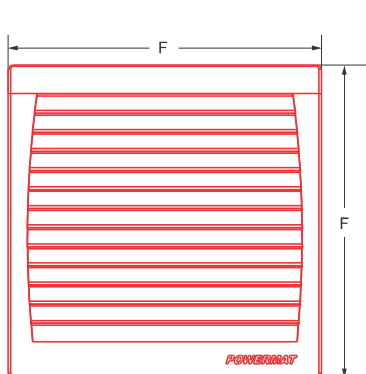

Powermat Code	Fan Size Inch	Over all Size F	Mounting M	Fan Mounting Cd	Thickness	Std. Pkg. (Nos.)	Box Wt. (Kg.)
EV 100	4	131 x 131mm	105 x 105mm	105 x 105mm	23	142	17.300
EV 150	6	185 x 185mm	155 x 155mm	155 x 155mm	25	50	11.920
EV 200	8	236 x 236mm	204 x 204mm	204 x 204mm	30	50	19.000



- Material : ABS (High Grade)
- Degree of protection : IP-54
- Filter Micron Size

Steel / Brass Threaded Spacers

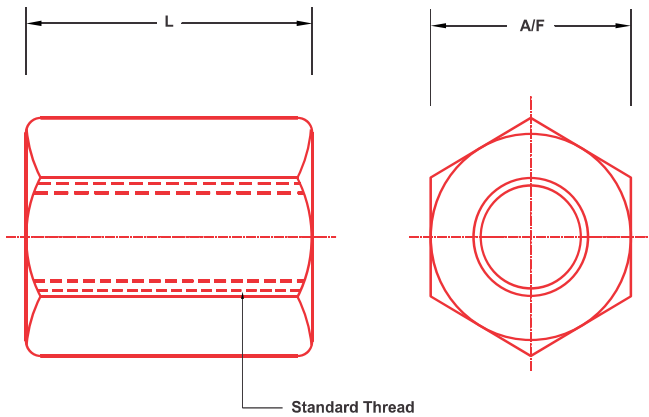

POWERMAT code	Dimension		
	Thread	L	A / F
SPACER FOR M 2.5			
PTS/M2.5/AF5/L3	M 2.5	3	5
PTS/M2.5/AF5/L4	M 2.5	4	5
PTS/M2.5/AF5/L5	M 2.5	5	5
PTS/M2.5/AF5/L6	M 2.5	6	5
PTS/M2.5/AF5/L7	M 2.5	7	5
PTS/M2.5/AF5/L8	M 2.5	8	5
PTS/M2.5/AF5/L9	M 2.5	9	5
PTS/M2.5/AF5/L10	M 2.5	10	5
PTS/M2.5/AF5/L11	M 2.5	11	5
PTS/M2.5/AF5/L12	M 2.5	12	5
PTS/M2.5/AF5/L13	M 2.5	13	5
PTS/M2.5/AF5/L14	M 2.5	14	5
PTS/M2.5/AF5/L15	M 2.5	15	5

SPACER FOR M 3

PTS/M3/AF5/L3	M 3	3	5
PTS/M3/AF5/L4	M 3	4	5
PTS/M3/AF5/L5	M 3	5	5
PTS/M3/AF5/L6	M 3	6	5
PTS/M3/AF5/L7	M 3	7	5
PTS/M3/AF5/L8	M 3	8	5
PTS/M3/AF5/L9	M 3	9	5
PTS/M3/AF5/L10	M 3	10	5
PTS/M3/AF5/L11	M 3	11	5
PTS/M3/AF5/L12	M 3	12	5
PTS/M3/AF5/L13	M 3	13	5
PTS/M3/AF5/L14	M 3	14	5
PTS/M3/AF5/L15	M 3	15	5

SPACER FOR M 4

PTS/M4/AF7/L3	M 4	3	7
PTS/M4/AF7/L4	M 4	4	7
PTS/M4/AF7/L5	M 4	5	7
PTS/M4/AF7/L6	M 4	6	7
PTS/M4/AF7/L7	M 4	7	7
PTS/M4/AF7/L8	M 4	8	7
PTS/M4/AF7/L9	M 4	9	7
PTS/M4/AF7/L10	M 4	10	7
PTS/M4/AF7/L11	M 4	11	7
PTS/M4/AF7/L12	M 4	12	7
PTS/M4/AF7/L13	M 4	13	7
PTS/M4/AF7/L14	M 4	14	7
PTS/M4/AF7/L15	M 4	15	7

- All Dimensions are in MM
- Material : Brass / Steel (Zinc Passivated) (Steel grade EN-1AL)

POWERMAT code	Thread	Dimension		
		L	A/F	L 1
SPACER FOR M2.5				
PSP/M2.5/AF5/L18	M 2.5	18	5	8
PSP/M2.5/AF5/L20	M 2.5	20	5	8
PSP/M2.5/AF5/L25	M 2.5	25	5	8
PSP/M2.5/AF5/L30	M 2.5	30	5	10
PSP/M2.5/AF5/L35	M 2.5	35	5	10
PSP/M2.5/AF5/L40	M 2.5	40	5	10

SPACER FOR M3

PSP/M3/AF5/L22	M 3	22	5	8
PSP/M3/AF5/L25	M 3	25	5	8
PSP/M3/AF5/L30	M 3	30	5	10
PSP/M3/AF5/L35	M 3	35	5	10
PSP/M3/AF5/L40	M 3	40	5	10
PSP/M3/AF5/L45	M 3	45	5	10
PSP/M3/AF5/L50	M 3	50	5	10
PSP/M3/AF5/L55	M 3	55	5	10
PSP/M3/AF5/L60	M 3	60	5	10

SPACER FOR M4

PSP/M4/AF7/L20	M 4	20	7	8
PSP/M4/AF7/L22	M 4	22	7	8
PSP/M4/AF7/L25	M 4	25	7	8
PSP/M4/AF7/L30	M 4	30	7	10
PSP/M4/AF7/L35	M 4	35	7	10
PSP/M4/AF7/L40	M 4	40	7	10
PSP/M4/AF7/L45	M 4	45	7	10
PSP/M4/AF7/L50	M 4	50	7	10
PSP/M4/AF7/L55	M 4	55	7	10
PSP/M4/AF7/L60	M 4	60	7	10
PSP/M4/AF7/L70	M 4	70	7	10
PSP/M4/AF7/L80	M 4	80	7	10

SPACER FOR M5

PSP/M5/AF8/L20	M 5	20	8	8
PSP/M5/AF8/L22	M 5	22	8	8
PSP/M5/AF8/L25	M 5	25	8	8
PSP/M5/AF8/L30	M 5	30	8	10
PSP/M5/AF8/L35	M 5	35	8	10
PSP/M5/AF8/L40	M 5	40	8	10
PSP/M5/AF8/L45	M 5	45	8	10
PSP/M5/AF8/L50	M 5	50	8	10
PSP/M5/AF8/L55	M 5	55	8	10
PSP/M5/AF8/L60	M 5	60	8	10
PSP/M5/AF8/L70	M 5	70	8	10
PSP/M5/AF8/L80	M 5	80	8	10

SPACER FOR M6

PSP/M6/AF10/L35	M 6	35	10	10
PSP/M6/AF10/L40	M 6	40	10	10
PSP/M6/AF10/L45	M 6	45	10	10
PSP/M6/AF10/L50	M 6	50	10	10
PSP/M6/AF10/L55	M 6	55	10	10
PSP/M6/AF10/L60	M 6	60	10	10
PSP/M6/AF10/L70	M 6	70	10	10
PSP/M6/AF10/L80	M 6	80	10	10

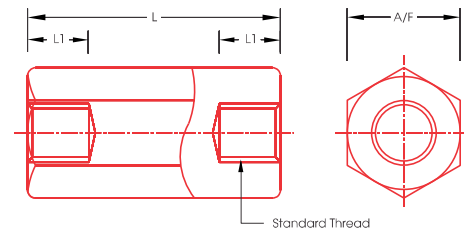

• All Dimensions are in MM
• Material : Brass / Steel (Zinc Passivated) (Steel grade EN-1AL)

Standoff Pillar

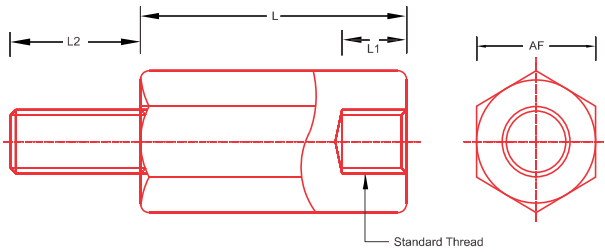

POWERMAT code	Thread	Dimension			
SPACER FOR M2.5		L	A/F	L 1	L 2
PMFP/M2.5/AF5/L10	M 2.5	10	5	6	6
PMFP/M2.5/AF5/L12	M 2.5	12	5	6	6
PMFP/M2.5/AF5/L15	M 2.5	15	5	6	6
PMFP/M2.5/AF5/L18	M 2.5	18	5	6	6
PMFP/M2.5/AF5/L20	M 2.5	20	5	6	6
PMFP/M2.5/AF5/L25	M 2.5	25	5	6	6
PMFP/M2.5/AF5/L30	M 2.5	30	5	6	6
PMFP/M2.5/AF5/L35	M 2.5	35	5	6	6
PMFP/M2.5/AF5/L40	M 2.5	40	5	6	6

SPACER FOR M3

PMFP/M3/AF5/L10	M 3	10	5	8	6
PMFP/M3/AF5/L12	M 3	12	5	8	8
PMFP/M3/AF5/L15	M 3	15	5	10	8
PMFP/M3/AF5/L18	M 3	18	5	10	8
PMFP/M3/AF5/L20	M 3	20	5	10	8
PMFP/M3/AF5/L25	M 3	25	5	10	10
PMFP/M3/AF5/L30	M 3	30	5	10	10
PMFP/M3/AF5/L35	M 3	35	5	10	10
PMFP/M3/AF5/L40	M 3	40	5	10	10
PMFP/M3/AF5/L45	M 3	45	5	10	10
PMFP/M3/AF5/L50	M 3	50	5	10	10
PMFP/M3/AF5/L55	M 3	55	5	10	10
PMFP/M3/AF5/L60	M 3	60	5	10	10

SPACER FOR M4

PMFP/M4/AF7/L10	M 4	10	7	8	6
PMFP/M4/AF7/L12	M 4	12	7	8	8
PMFP/M4/AF7/L15	M 4	15	7	10	8
PMFP/M4/AF7/L18	M 4	18	7	10	8
PMFP/M4/AF7/L20	M 4	20	7	10	8
PMFP/M4/AF7/L25	M 4	25	7	10	10
PMFP/M4/AF7/L30	M 4	30	7	10	10
PMFP/M4/AF7/L35	M 4	35	7	10	10
PMFP/M4/AF7/L40	M 4	40	7	10	10
PMFP/M4/AF7/L45	M 4	45	7	10	10
PMFP/M4/AF7/L50	M 4	50	7	10	10
PMFP/M4/AF7/L55	M 4	55	7	10	10
PMFP/M4/AF7/L60	M 4	60	7	10	10

POWERMAT code	Thread	Dimension			
SPACER FOR M5		L	A/F	L 1	L 2
PMFP/M5/AF8/L10	M 5	10	8	8	8
PMFP/M5/AF8/L12	M 5	12	8	8	8
PMFP/M5/AF8/L15	M 5	15	8	10	8
PMFP/M5/AF8/L18	M 5	18	8	10	8
PMFP/M5/AF8/L20	M 5	20	8	10	8
PMFP/M5/AF8/L25	M 5	25	8	10	10
PMFP/M5/AF8/L30	M 5	30	8	10	10
PMFP/M5/AF8/L35	M 5	35	8	10	10
PMFP/M5/AF8/L40	M 5	40	8	10	10
PMFP/M5/AF8/L45	M 5	45	8	10	10
PMFP/M5/AF8/L50	M 5	50	8	10	10
PMFP/M5/AF8/L55	M 5	55	8	10	10
PMFP/M5/AF8/L60	M 5	60	8	10	10
PMFP/M5/AF8/L70	M 5	70	8	10	10
PMFP/M5/AF8/L80	M 5	80	8	10	10

SPACER FOR M6

PMFP/M6/AF10/L10	M 6	10	10	8	10
PMFP/M6/AF10/L12	M 6	12	10	8	10
PMFP/M6/AF10/L15	M 6	15	10	10	10
PMFP/M6/AF10/L18	M 6	18	10	10	10
PMFP/M6/AF10/L20	M 6	20	10	10	10
PMFP/M6/AF10/L25	M 6	25	10	10	10
PMFP/M6/AF10/L30	M 6	30	10	10	10
PMFP/M6/AF10/L35	M 6	35	10	10	10
PMFP/M6/AF10/L40	M 6	40	10	10	10
PMFP/M6/AF10/L45	M 6	45	10	10	10
PMFP/M6/AF10/L50	M 6	50	10	10	10
PMFP/M6/AF10/L55	M 6	55	10	10	10
PMFP/M6/AF10/L60	M 6	60	10	10	10
PMFP/M6/AF10/L70	M 6	70	10	10	10
PMFP/M6/AF10/L80	M 6	80	10	10	10
PMFP/M6/AF10/L100	M 6	100	10	10	10

- All Dimensions are in MM
- Material : Brass / Steel (Zinc Passivated) (Steel grade EN-1AL)

POWERMAT code SPACER FOR M2	Dimension		
	L	O.D	I.D
PCS/04/122/L3	3	4	2.2
PCS/04/122/L4	4	4	2.2
PCS/04/122/L5	5	4	2.2
PCS/04/122/L6	6	4	2.2
PCS/04/122/L7	7	4	2.2
PCS/04/122/L8	8	4	2.2
PCS/04/122/L9	9	4	2.2
PCS/04/122/L10	10	4	2.2
PCS/04/122/L11	11	4	2.2
PCS/04/122/L12	12	4	2.2
PCS/04/122/L13	13	4	2.2
PCS/04/122/L14	14	4	2.2
PCS/04/122/L15	15	4	2.2
PCS/04/122/L18	18	4	2.2
PCS/04/122/L20	20	4	2.2
PCS/04/122/L25	25	4	2.2
PCS/04/122/L30	30	4	2.2

SPACER FOR M2.5

PCS/05/127/L3	3	5	2.7
PCS/05/127/L4	4	5	2.7
PCS/05/127/L5	5	5	2.7
PCS/05/127/L6	6	5	2.7
PCS/05/127/L7	7	5	2.7
PCS/05/127/L8	8	5	2.7
PCS/05/127/L9	9	5	2.7
PCS/05/127/L10	10	5	2.7
PCS/05/127/L11	11	5	2.7
PCS/05/127/L12	12	5	2.7
PCS/05/127/L13	13	5	2.7
PCS/05/127/L14	14	5	2.7
PCS/05/127/L15	15	5	2.7
PCS/05/127/L18	18	5	2.7
PCS/05/127/L20	20	5	2.7
PCS/05/127/L25	25	5	2.7
PCS/05/127/L30	30	5	2.7

SPACER FOR M3

PCS/06/132/L3	3	6	3.2
PCS/06/132/L4	4	6	3.2
PCS/06/132/L5	5	6	3.2
PCS/06/132/L6	6	6	3.2
PCS/06/132/L7	7	6	3.2
PCS/06/132/L8	8	6	3.2
PCS/06/132/L9	9	6	3.2
PCS/06/132/L10	10	6	3.2
PCS/06/132/L11	11	6	3.2
PCS/06/132/L12	12	6	3.2
PCS/06/132/L13	13	6	3.2
PCS/06/132/L14	14	6	3.2
PCS/06/132/L15	15	6	3.2
PCS/06/132/L18	18	6	3.2
PCS/06/132/L20	20	6	3.2
PCS/06/132/L25	25	6	3.2
PCS/06/132/L30	30	6	3.2

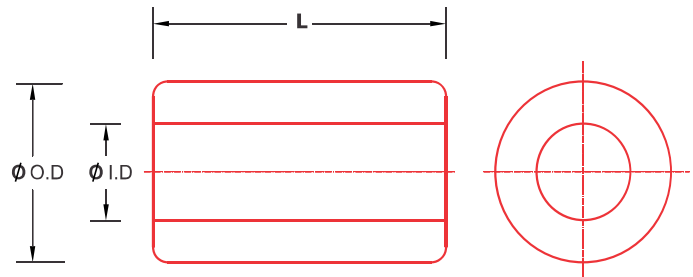

POWERMAT code SPACER FOR M4	Dimension		
	L	O.D	I.D
PCS/08/142/L3	3	8	4.2
PCS/08/142/L4	4	8	4.2
PCS/08/142/L5	5	8	4.2
PCS/08/142/L6	6	8	4.2
PCS/08/142/L7	7	8	4.2
PCS/08/142/L8	8	8	4.2
PCS/08/142/L9	9	8	4.2
PCS/08/142/L10	10	8	4.2
PCS/08/142/L11	11	8	4.2
PCS/08/142/L12	12	8	4.2
PCS/08/142/L13	13	8	4.2
PCS/08/142/L14	14	8	4.2
PCS/08/142/L15	15	8	4.2
PCS/08/142/L18	18	8	4.2
PCS/08/142/L20	20	8	4.2
PCS/08/142/L25	25	8	4.2
PCS/08/142/L30	30	8	4.2

• All Dimensions are in MM
• Material : Brass / Steel (Zinc Passivated) (Steel grade EN-1AL)

Mounting Detail

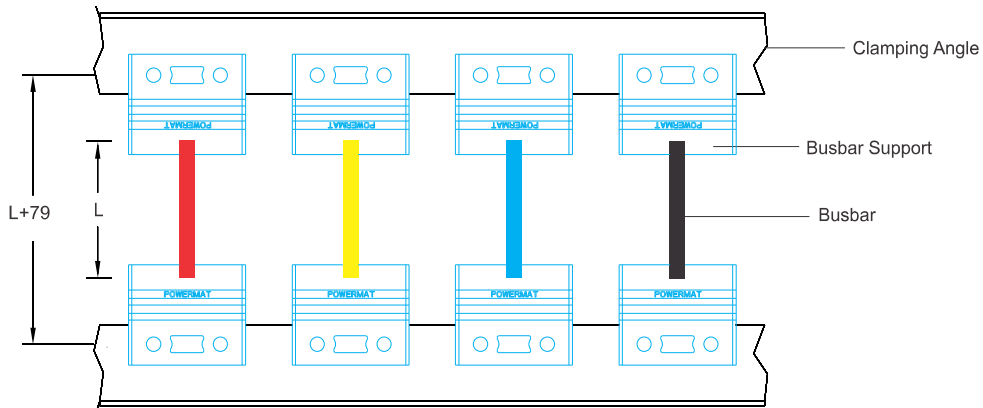
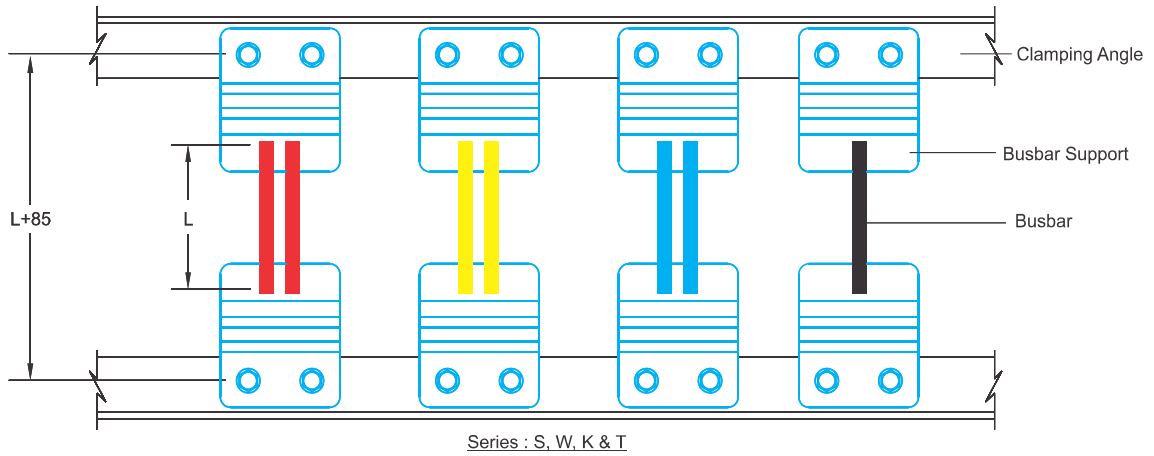
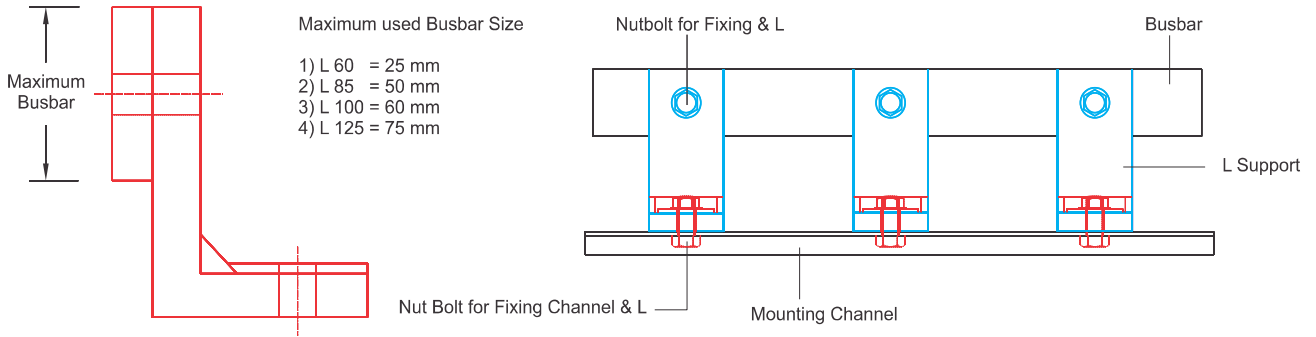
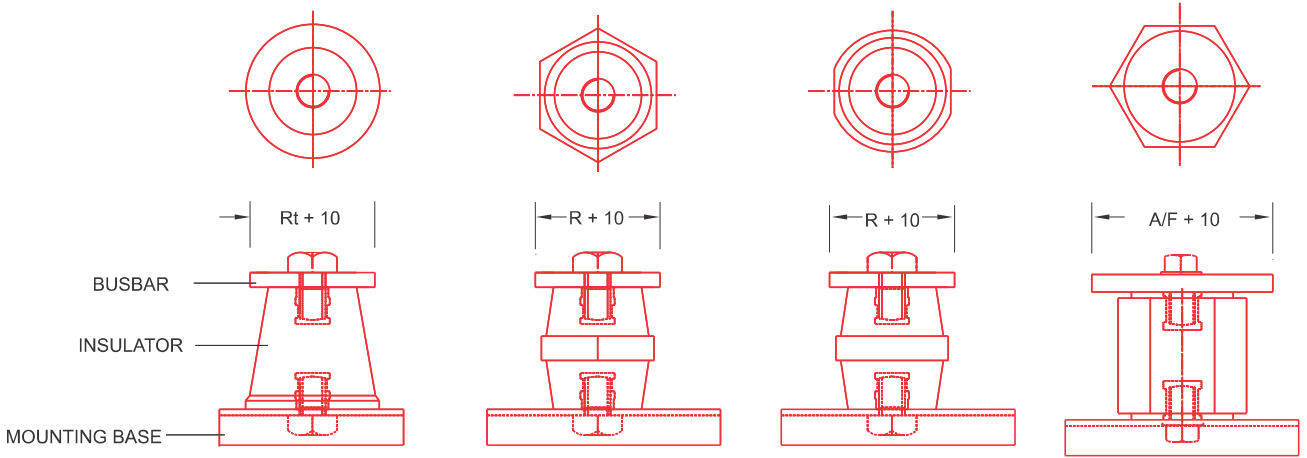

Mounting Details of Polyamide Finger Type Support (N-Series)

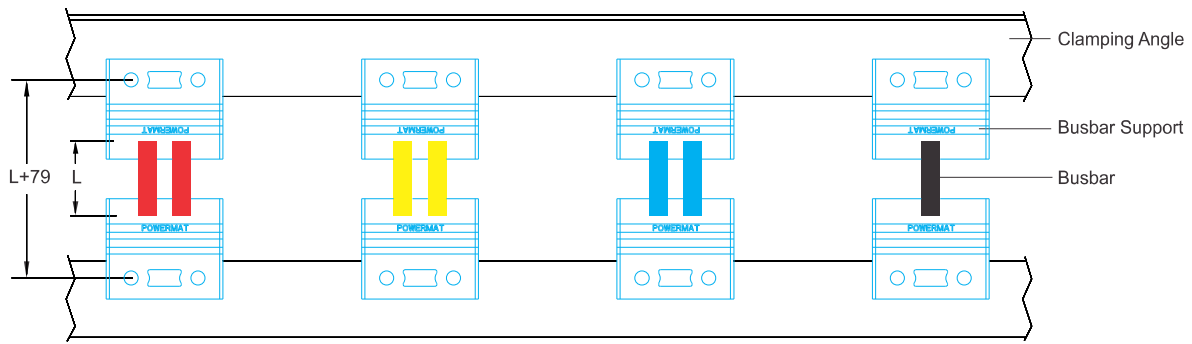

Mounting Details of Polyamide Finger Type Support (N-Series)

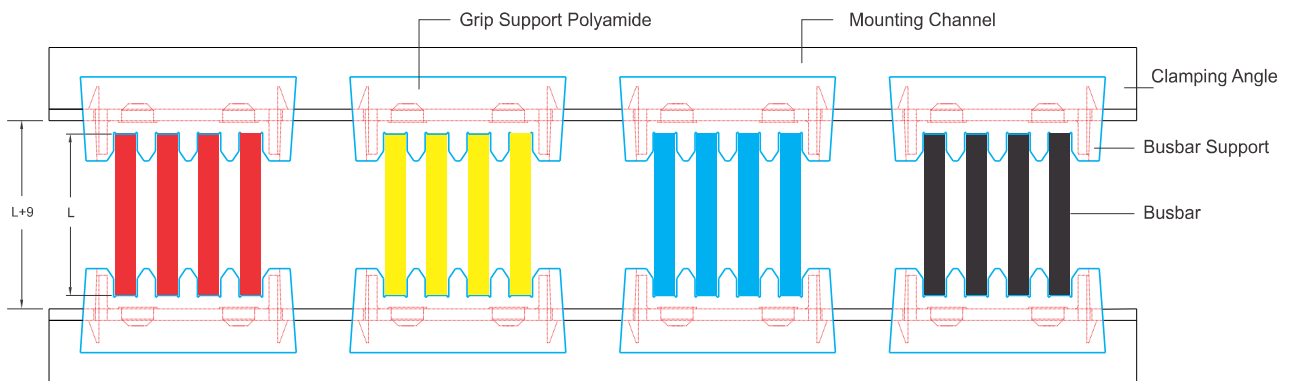

Mounting detail of PAGP 407

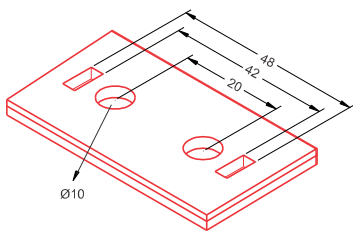

Mounting Fixture for
PAGP Series 110, 112, 206, 210, 307

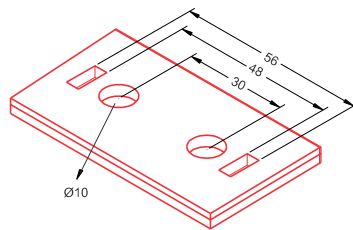

Mounting Fixture for PAGP-407

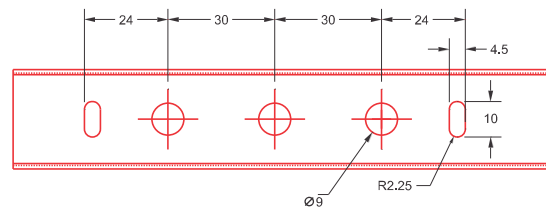

Mounting Fixture for 118 PAGP-510

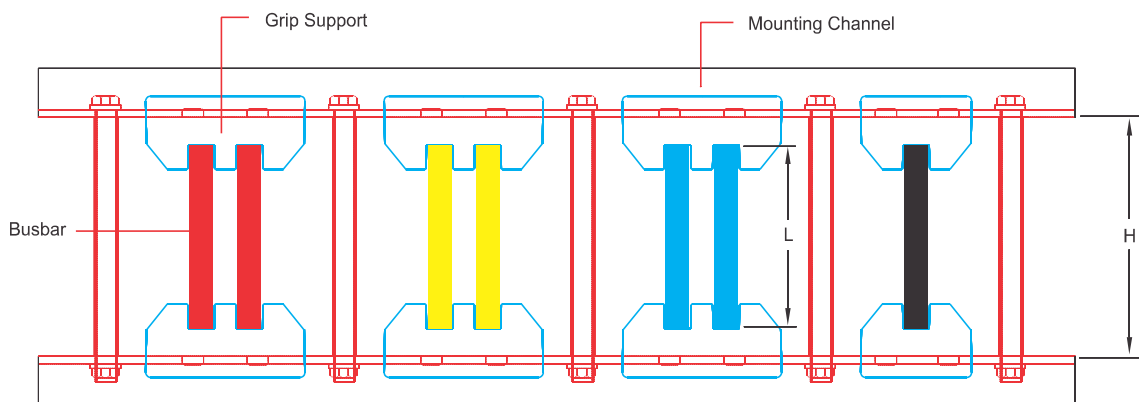

H for GP Series L+15
H for GPS Series L+10

Mounting Detail

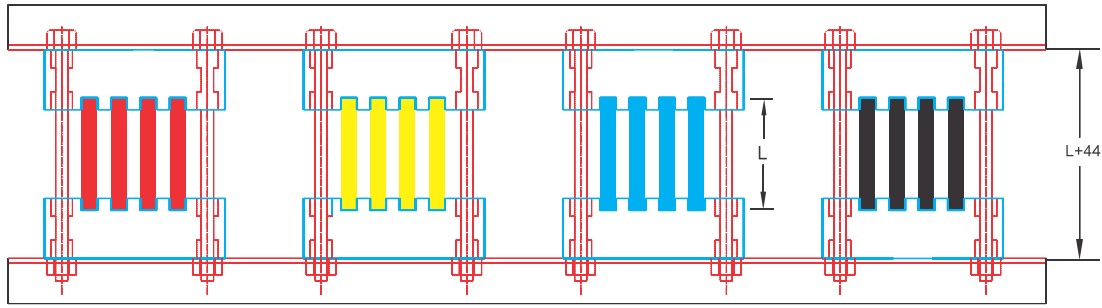

Mounting Details of N 22P 411/000

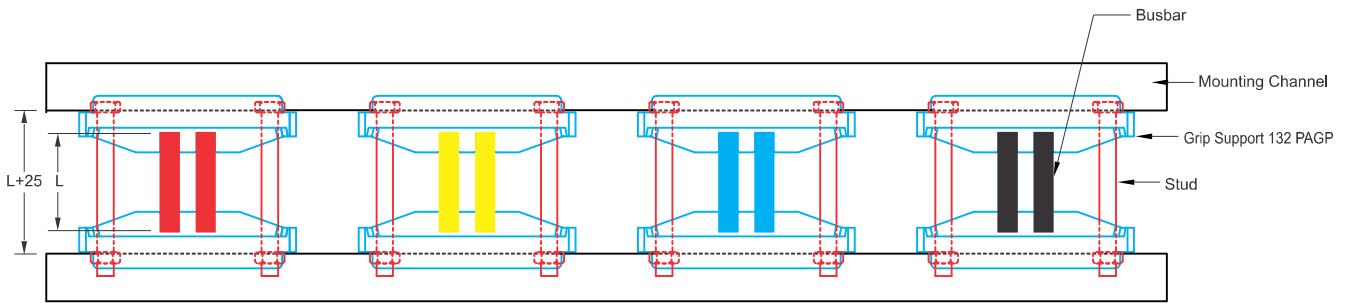

Mounting Details of 132 PAGP Series

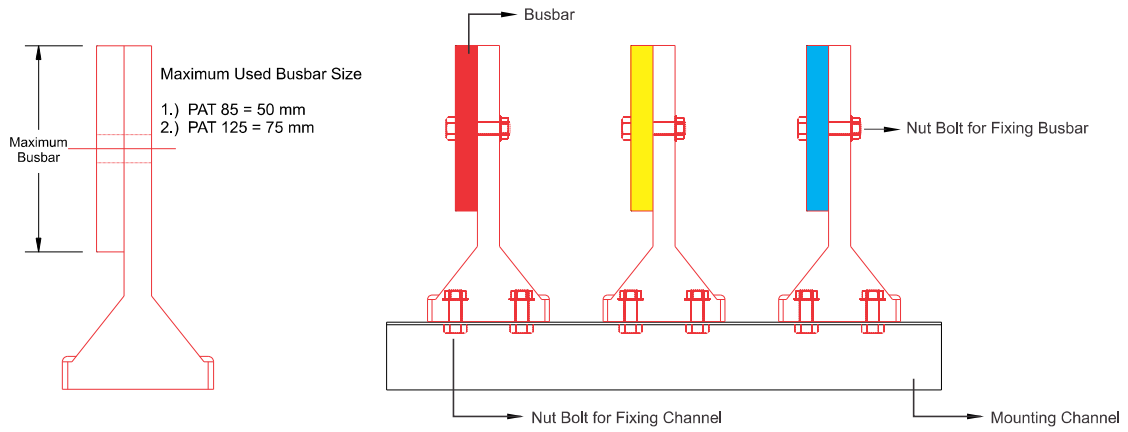

Mounting Details of PAT Series

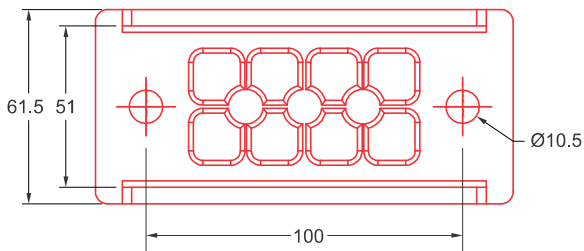

Bottom Details of 132 PAGP Series

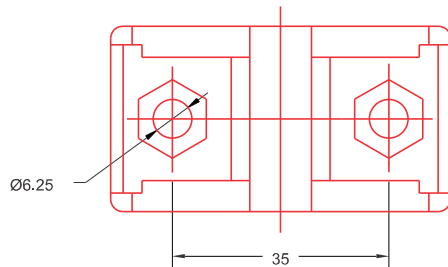

Top Details of PAT Series

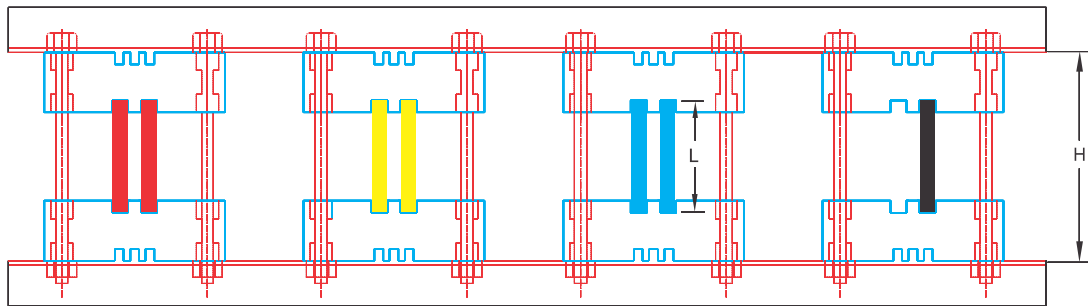
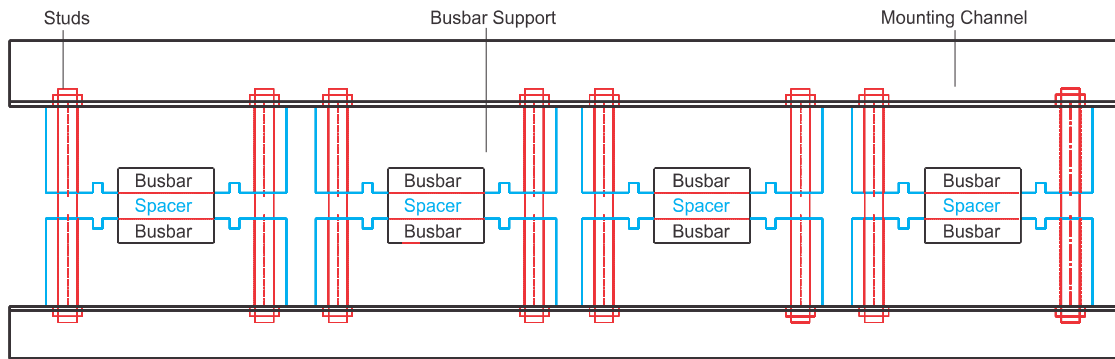

$H = L + 64\text{mm}$ (for 10p, 11p, 12p, 14p Series)
 $H = L + 44\text{mm}$ (for 20p, 21p, 22p, 24p Series)

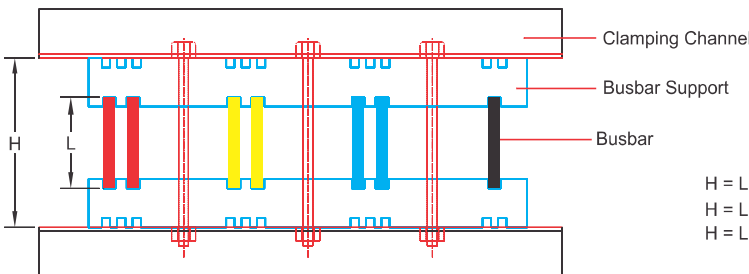

$H = L + 64\text{mm}$ (for 30p, 31p, 32p, 42p, 43p, 65p Series)
 $H = L + 93\text{mm}$ (for 45p Series)
 $H = L + 54\text{mm}$ (for 60p, 61p, 62p Series)

$L = \text{Bus Bar Length}$

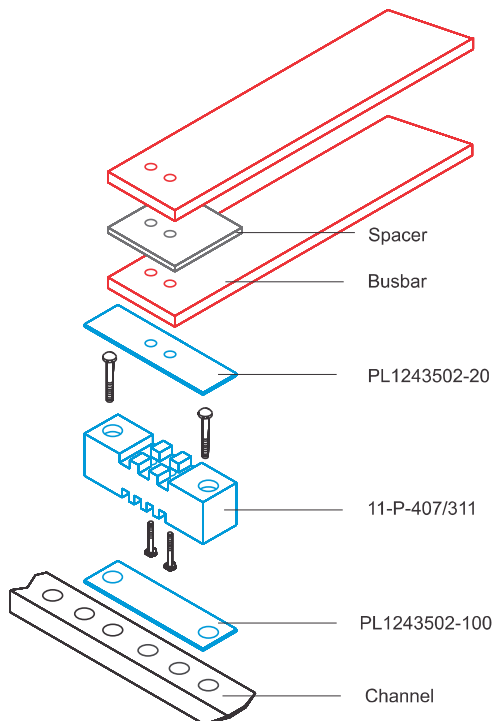

Torque chart - recommended values - indicative only

Metric Bolt Size	Torque N-m
M 4	2.3 - 2.9
M 5	4.5 - 6.0
M 6	7.7 - 10
M 8	19 - 25
M 10	37 - 49
M 12	65 - 86
M 16	155 - 210
M 20	305 - 410
M 22	415 - 550

* Range for Bolt used Grade 6.8 - 8.8

Insert Material & Grade

Material	Grade
Mild Steel (MS)	EN1AL
Aluminium Alloy (Al)	6061 - T6
Brass (B)	BS EN12164 CW 614N
Stainless Steel (SS)	303L

Mounting Detail

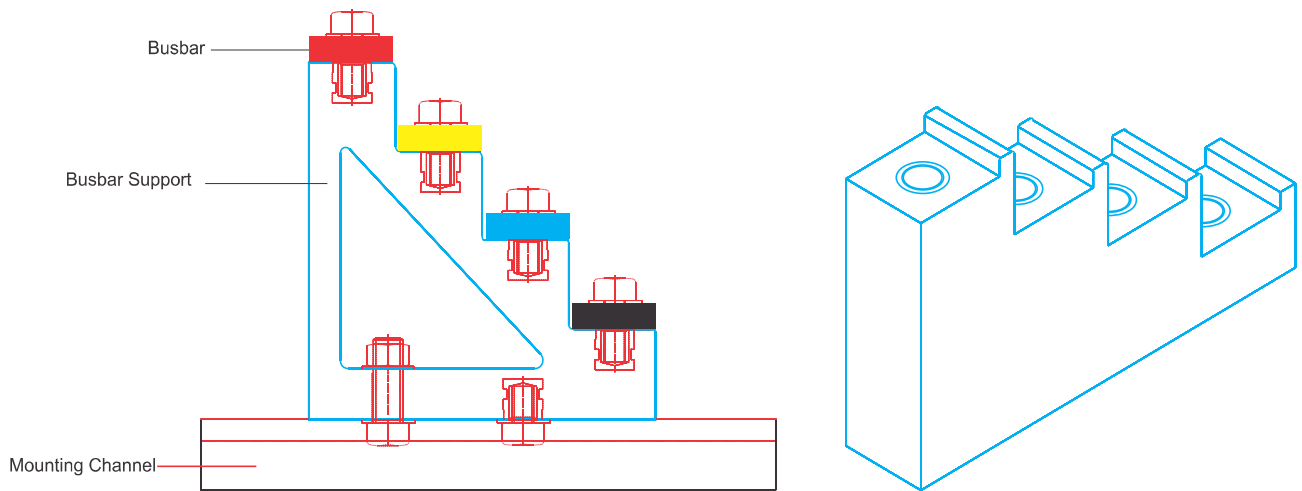

30, 40, 50 Series

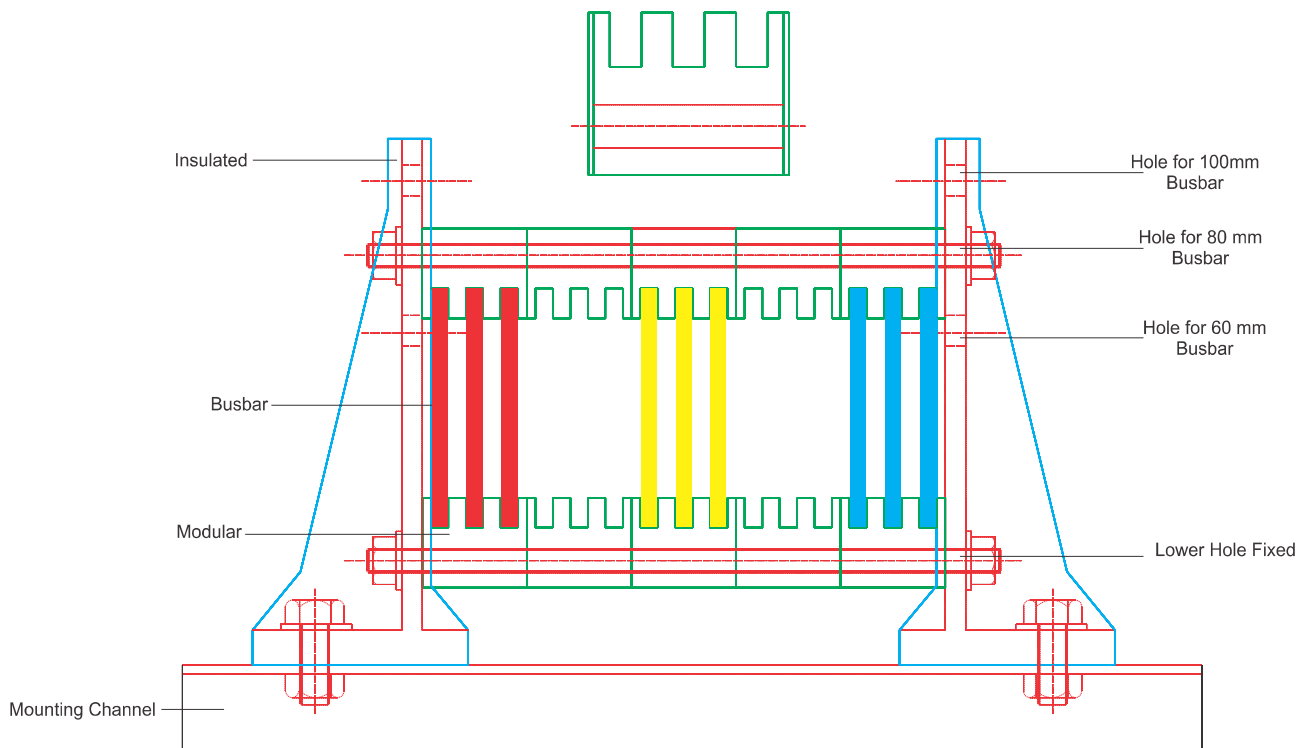
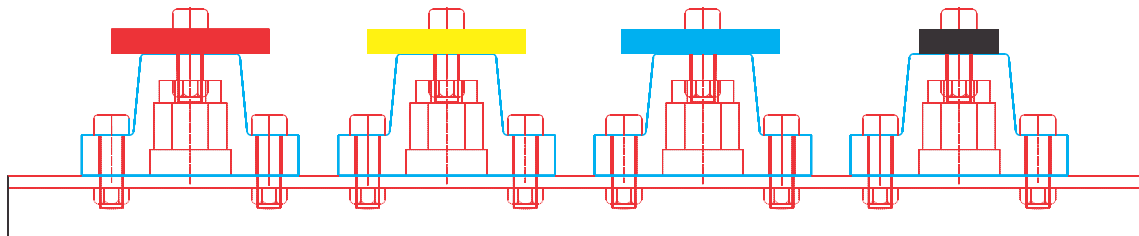

POWERMAT Commitment to being a full-service manufacturing company

- Fully trained Work Force in Quality Control Program.
- Total Quality Management program of continuous improvement.
- Just-In-Time delivery.
- CAD/CAM engineering services.
- Keep bringing new & Innovative manifestations of perfect engineering for the end use.
- Tooling facilities for the fastest response.
- State of the art computerised testing machines for testing raw materials and finished components.
- Consultancy for using of Bus Bar Supports in Power Control Centres & Bus Ducts under fault level conditions.
- Customer service with a mind of urgency.

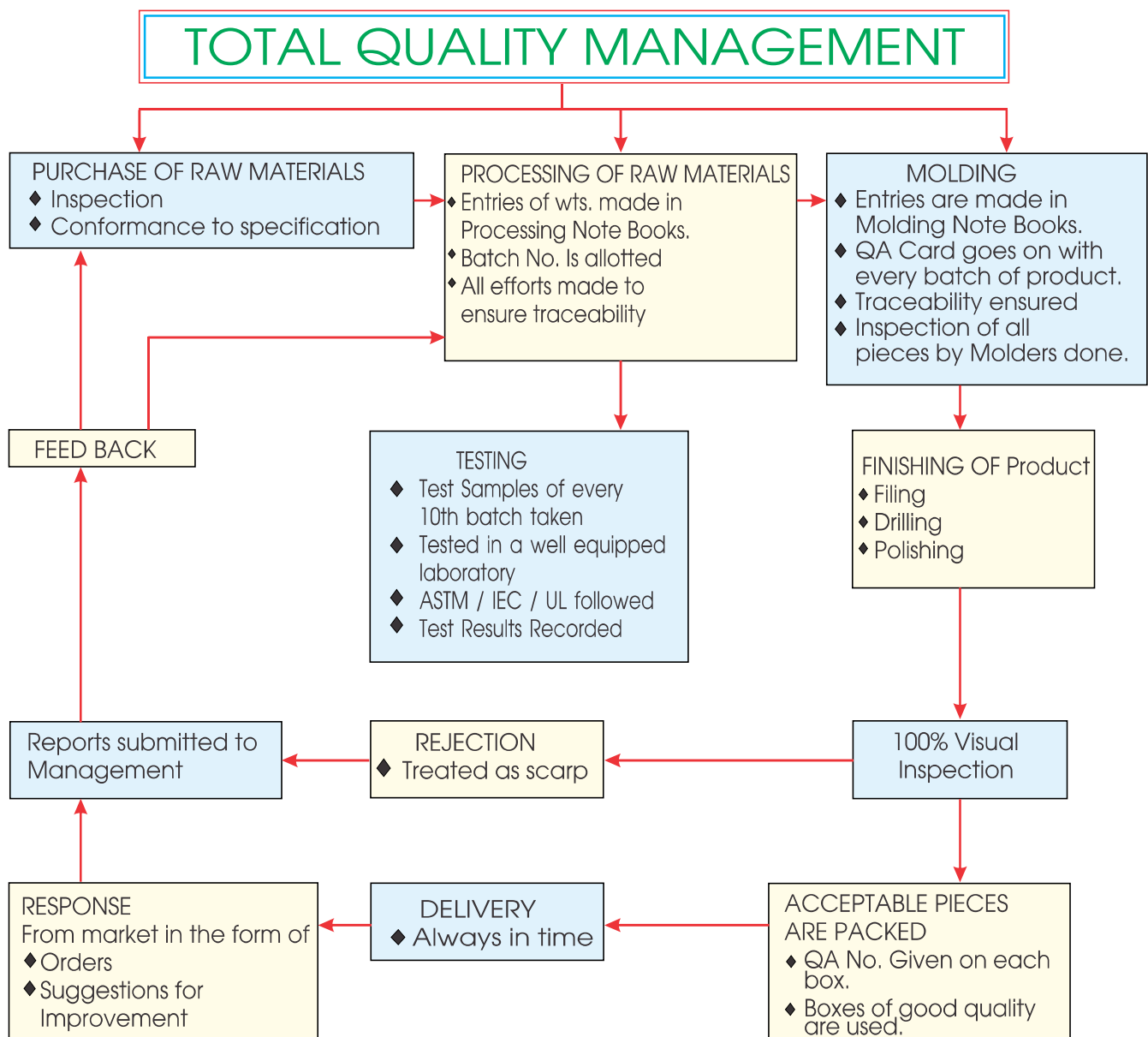

NO FULL STOP AT POWERMAT

POWERMAT

GLOBAL COMMITMENT



BHARAT
TRADING CORPORATION

📍 396/1, Budhwar Peth, Opp. Mahavir Market, Cholkhanali, Pune - 411 002.

☎ +91 - 020 - 67257500 / 24478185

📱 +91 - 8806668101

✉ info@btc.net.in

🌐 www.btc.net.in